

High Sensitivity Micropower Linear Hall-effect Sensor

Features

- Ratiometric linear hall effect magnetic sensor
- Analog output with $V_{CC} / 2$ quiescent offset
- Operates from 2.5V to 5.5V power supplies
- Sensitivity selection: ($V_{CC} = 5V$)
AW86564ASTR: 3mV/Gs
- Temperature-stable quiescent voltage output and sensitivity
- Wide operating temperature range:
-40°C to +125°C
- Fast 10-kHz sensing bandwidth
- WBSOT23-3L package

Applications

- Accurate position detection
- Industrial automation robot
- Handheld gaming consoles
- Bluetooth headset
- Medical facility
- Domestic appliance

General Description

The AW86564ASTR is a linear Hall effect IC that respond proportionally to magnetic flux density. The quiescent output voltage of the device is 50 % nominal of the supply voltage V_{CC} and the supply current of the device is 2.6 mA.

The AW86564ASTR features magnet temperature compensation to counteract how magnets drift for linear performance across a wide -40°C to +125°C temperature range.

The AW86564ASTR is available in 3 pin SOT and is rated over -40°C to +125°C. The package is available in a lead (Pb)free version.

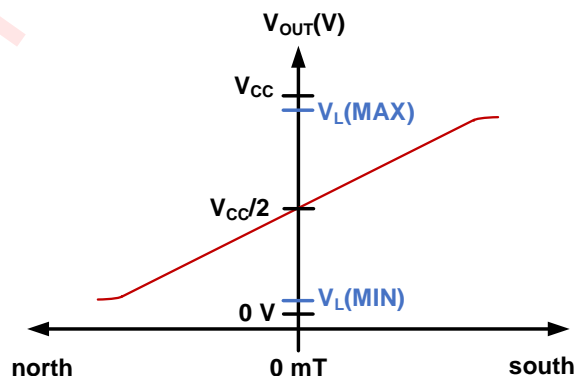

Figure 1 V_{OUT} versus Magnetic Field

Typical Application Circuit

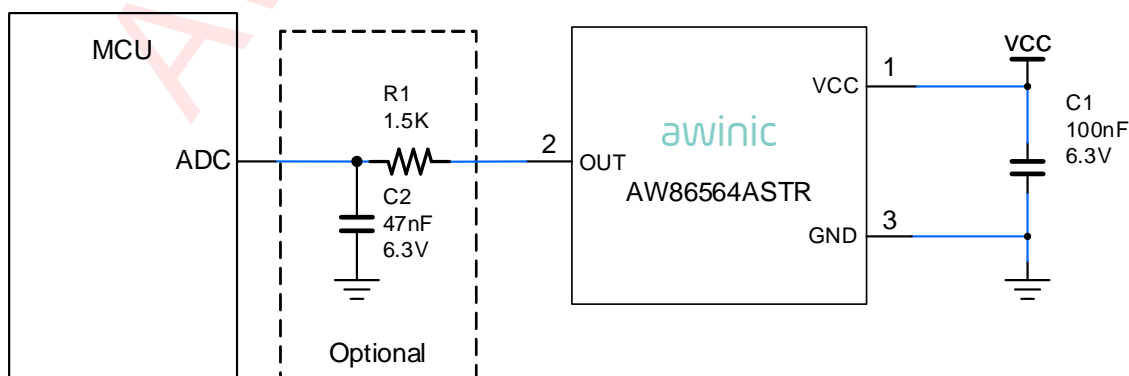

Figure 2 Typical Application Circuit of AW86564ASTR

Pin Configuration And Top Mark

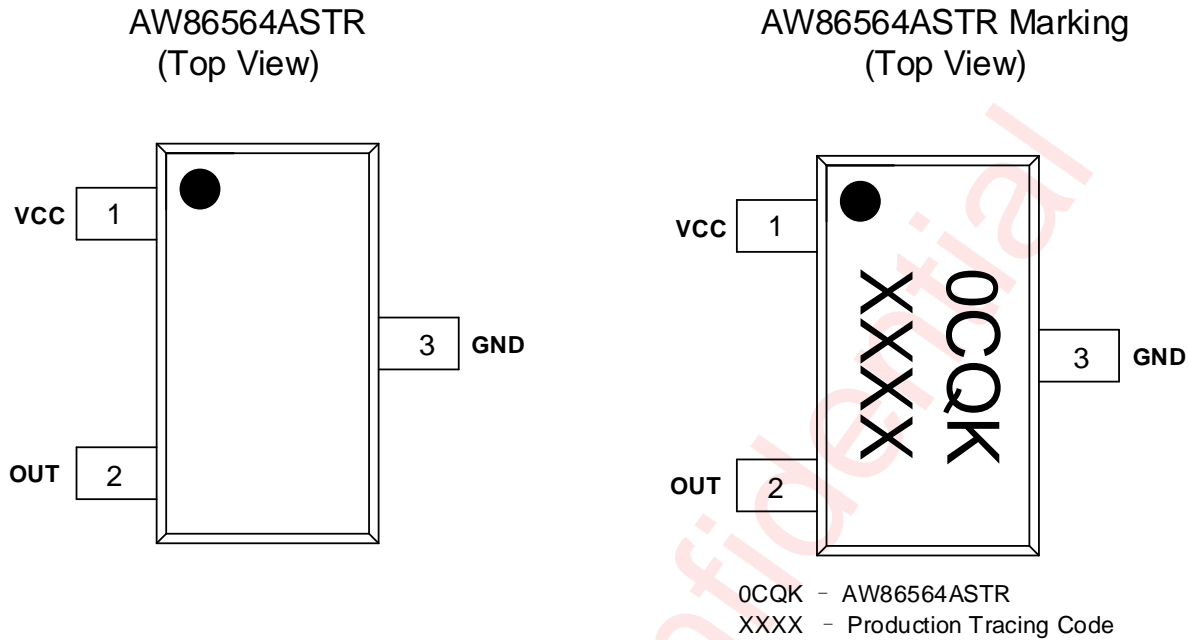

Figure 3 Pin Configuration And Top Mark

Pin Definition

No.	NAME	DESCRIPTION
1	VCC	Input power supply; tie to GND with bypass capacitor
2	OUT	Analog signal output
3	GND	Ground

Functional Block Diagram

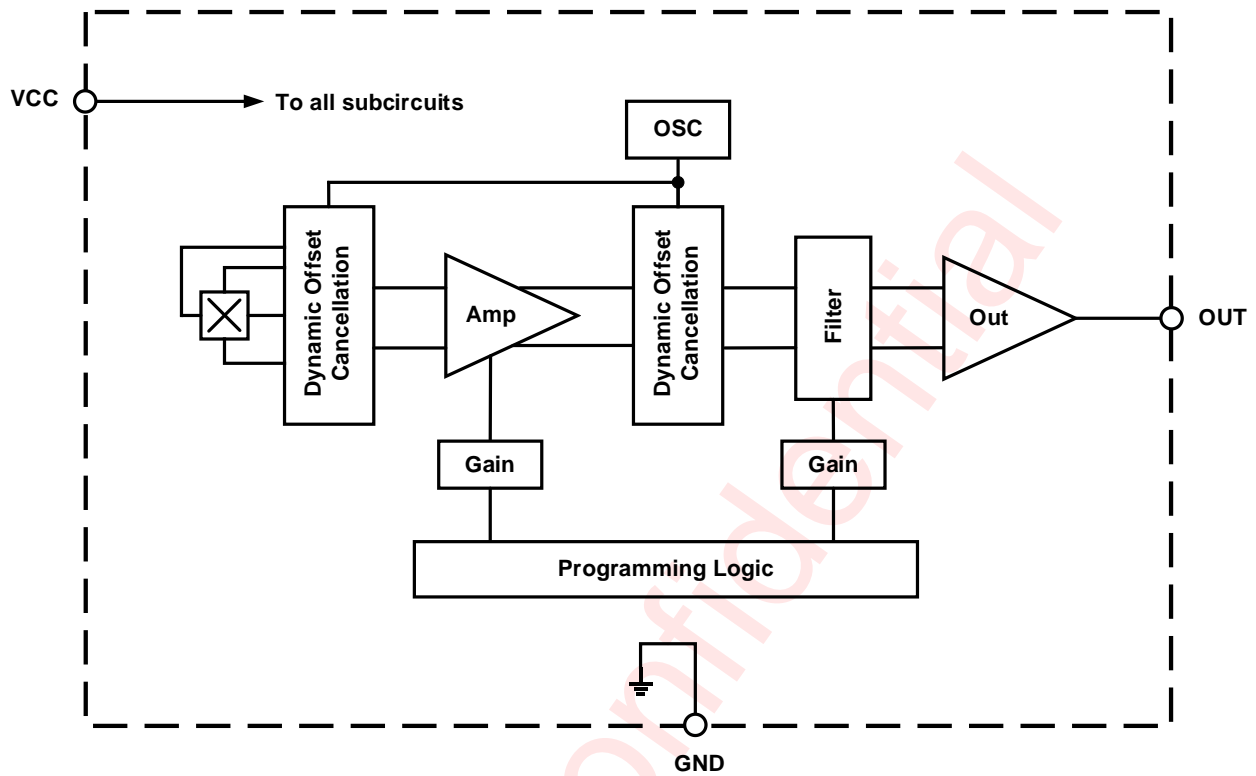

Figure 4 Functional Block Diagram

Ordering Information

Part Number	Temperature	Package	Marking	Moisture Sensitivity Level	Environmental Information	Delivery Form
AW86564ASTR	-40°C~125°C	WBSOT23-3L	0CQK	MSL3	ROHS+HF	3000 units/ Tape and Reel

Absolute Maximum Ratings

PARAMETERS	RANGE
VCC Power Supply Voltage	-0.1V to 6V
Output Voltage	-0.1V to V _{CC} +0.1V
Operating Ambient Temperature T _A	-40°C to 125°C
Storage Temperature T _{STG}	-65°C to 150°C
Junction temperature T _J	-50°C to 165°C
Magnetic Flux	No limit
Lead temperature (soldering 10 seconds)	260°C
ESD Rating ^(NOTE2 3)	
Human Body Model (HMB) ESD capability	±6000V
Charged-device model (CDM) ESD capability	±1500V
Latch-up	
Test Condition: JESD78E	+IT: 200mA
	-IT: 200mA

NOTE1: Conditions out of those ranges listed in "absolute maximum ratings" may cause permanent damages to the device. In spite of the limits above, functional operation conditions of the device should within the ranges listed in "recommended operating conditions". Exposure to absolute-maximum-rated conditions for prolonged periods may affect device reliability.

NOTE2: The human body model test method: ESDA/JEDEC JS -001-2017.

NOTE3: Charge Device Model test method: ESDA/JEDEC JS-002-2018.

Electrical Characteristics

T_A = 25°C, V_{CC} = 5V (unless otherwise noted)

PARAMETER		TEST CONDITION	MIN	TYP ¹	MAX	UNIT
V _{CC}	Supply Voltage		2.5	–	5.5	V
	V _{CC} ramp time	V _{CC} = 5V	–	–	10	ms
V _{CCN}	Nominal Supply Voltage		–	5.0	–	V
t _{PON} ²	Power-On Time ²	T _A = 25°C	–	120	–	µs
f _c	Chopper Stabilization Chopping Frequency	V _{CC} = V _{CCN} , T _A = 25°C	–	200	–	kHz
I _{CC}	Supply Current ³	V _{CC} = V _{CCN} , T _A = 25°C	–	2.7	–	mA
PSR _{VOQ}	Quiescent Output Power Supply Rejection ³	f _{AC} < 1 kHz	–	-60	–	dB

¹Typical data are for initial design estimations only, and assume optimum manufacturing and application conditions, such as T_A = 25°C. Performance may vary for individual units, within the specified maximum and minimum limits.

²See Characteristic Definitions section.

³ f_{AC} is any ac component frequency that exists on the supply line.

Output Characteristics

$T_A = 25^\circ\text{C}$, $V_{CC} = 5\text{V}$ (unless otherwise noted)

(1mT = 10Gs)

PARAMETER		TEST CONDITION	MIN	TYP ¹	MAX	UNIT
V_{OUTH}	Output Voltage Saturation Limits ²	$B = X$, $V_{CC} = V_{CCN}$	–	$V_{CC} - 0.1$	–	V
V_{OUTL}		$B = -X$, $V_{CC} = V_{CCN}$	–	0.1	–	V
V_{OUTMAX}	Maximum Voltage Applied to Output	$V_{CC} = V_{CCN}$	–	–	$V_{CC} + 0.1$	V
Sens	Sensitivity	$V_{CC} = V_{CCN}$, $T_A = 25^\circ\text{C}$	–	3	–	mV/Gs
V_{OUTQ}	Quiescent Output	$T_A = 25^\circ\text{C}$, $B = 0$ Gs	–	$0.5 \times V_{CC}$	–	V
R_{OUT}	Output Resistance ³	$f_{out} = 1$ kHz	–	20	–	Ω
R_L	Output Load Resistance	Output to ground	15	–	–	k Ω
C_L	Output Load Capacitance	Output to ground	–	–	1	nF
BW	Output Bandwidth	$V_{CC} = V_{CCN}$, -3 dB point, $V_{OUT} = 1$ V _{pp} sinusoidal,	–	10	–	kHz
V_{rms}	Noise ⁴ : AW86564ASTR	$C_{Bypass} = 100\text{nF}$ $R_{filter} = 1.5\text{k}\Omega$ $C_{filter} = 47\text{nF}$	–	0.96	–	mVrms
S_{TC}	Sensitivity temperature compensation for magnets	$-40^\circ\text{C} \leq T_A \leq 125^\circ\text{C}$	0.12			%/ $^\circ\text{C}$
S_{LE}	Sensitivity linear error	within the Output Voltage Saturation Range.		± 1		%

¹Typical data are for initial design estimations only, and assume optimum manufacturing and application conditions, such as $T_A = 25^\circ\text{C}$. Performance may vary for individual units, within the specified maximum and minimum limits.

²This test requires positive and negative magnetic fields sufficient to swing the output driver between fully OFF and saturated (ON), respectively. The value of vector X is not intended to indicate a range of linear operation.

³ f_{OUT} is the output signal frequency

⁴Noise specification includes digital and analog noise.

Magnetic Characteristics

T_A = 25°C, VCC = 2.5V to 5.5V(unless otherwise noted)

PARAMETER		MIN	TYP ¹	MAX	UNIT
$\Delta V_{OUTQ(\Delta V)}$	Ratiometry	–	99.5	–	%
Lin+	Positive Linearity	–	99.0	–	%
Lin-	Negative Linearity	–	99.0	–	%
Sym	Symmetry	–	98.0	–	%

¹Typical data are for initial design estimations only, and assume optimum manufacturing and application conditions, such as T_A = 25°C. Performance may vary for individual units, within the specified maximum and minimum limits.

Typical Characteristics

For T_A = 25°C (unless otherwise noted)

ELECTRICAL CHARACTERISTIC DATA

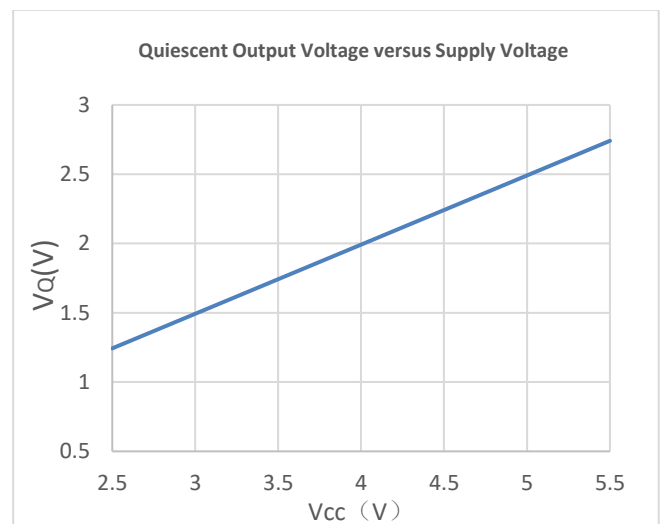
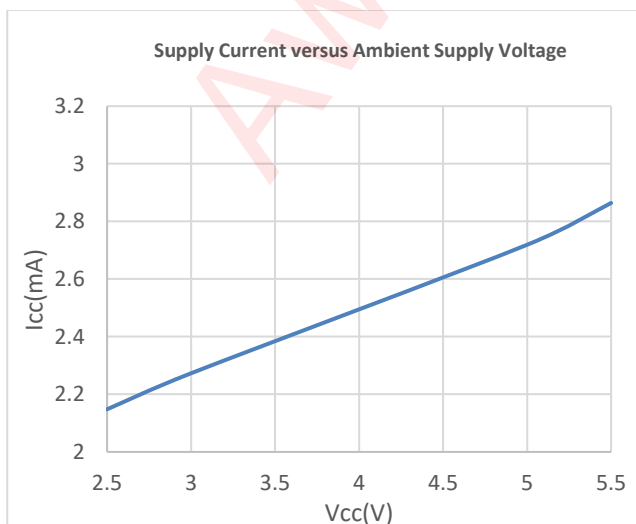
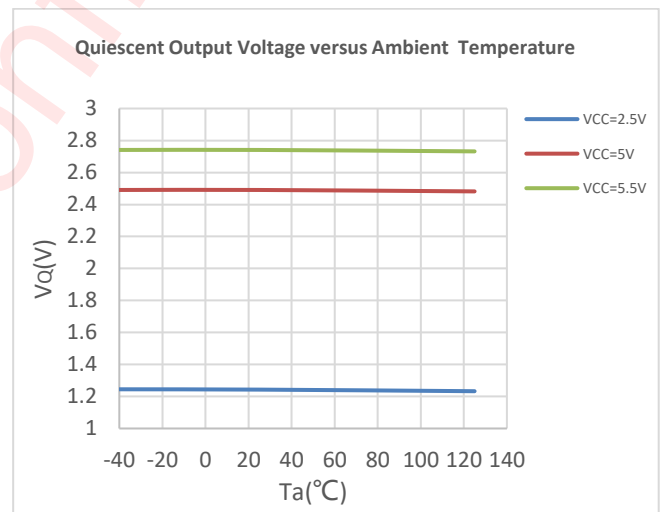
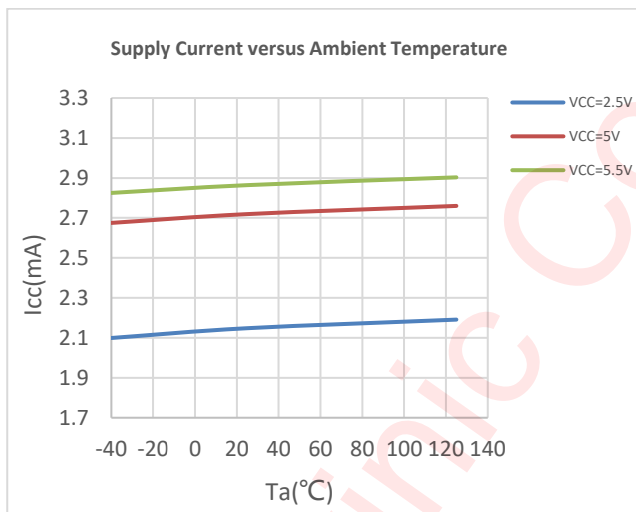

MAGNETIC CHARACTERISTIC DATA

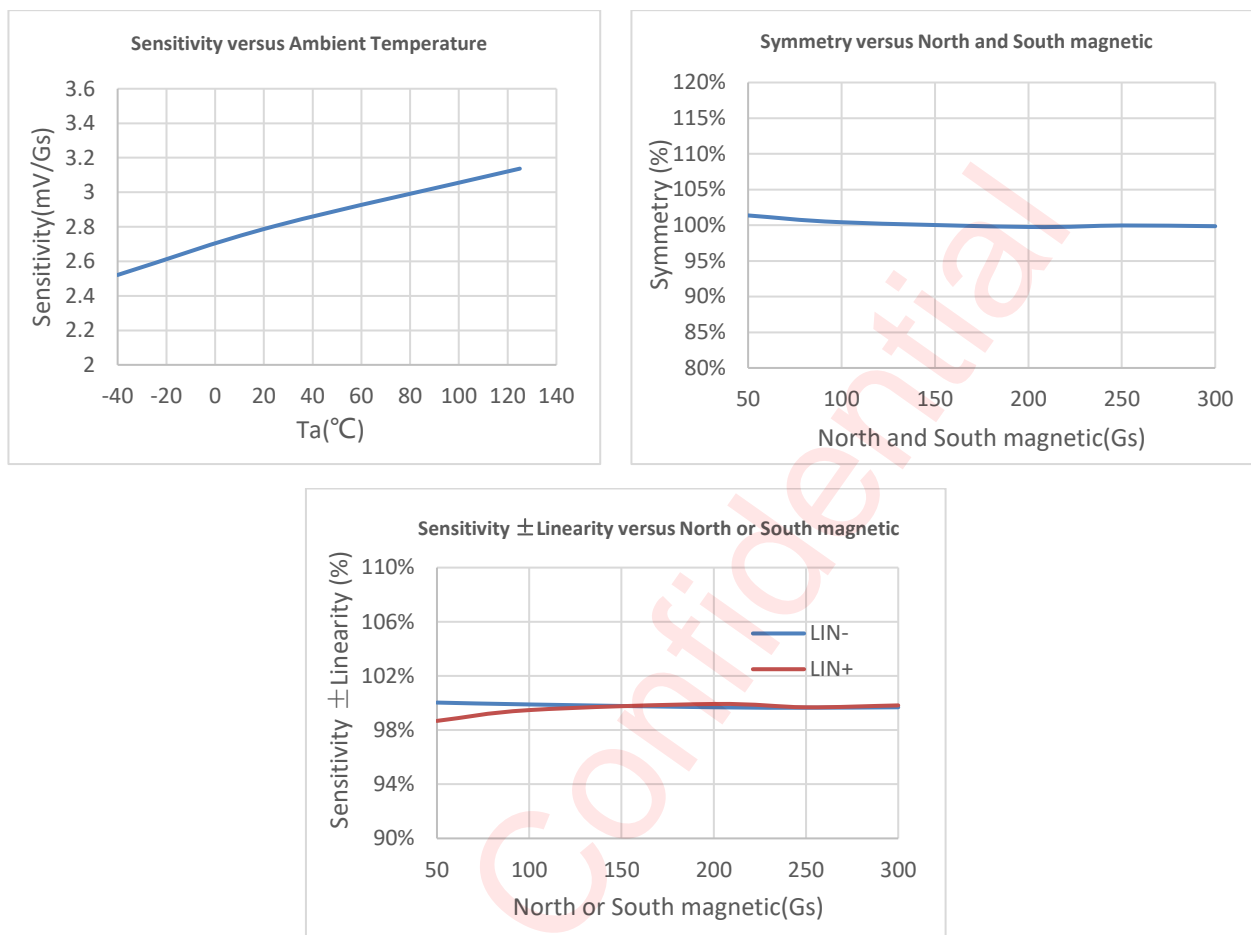

Characteristics Definitions

Temperature Compensation for Magnets. The magnetic field of a magnet usually becomes weaker as the temperature increases. The AW86564ASTR will increase the sensitivity to compensate.

The sensitivity at TA = 125°C is generally 12% higher than at TA = 25°C.

Power On Time. After the V_{CC} voltage is applied, the devices requires a short initialization time before the output is set. The parameter t_{pon} describes the time from when V_{CC} crosses its minimum specified operating voltage, V_{CC(min)}, until V_{OUT} is within 5% of V_Q, with 0Gs applied and no load attached to OUT.

Figure 5 shows this timing diagram.

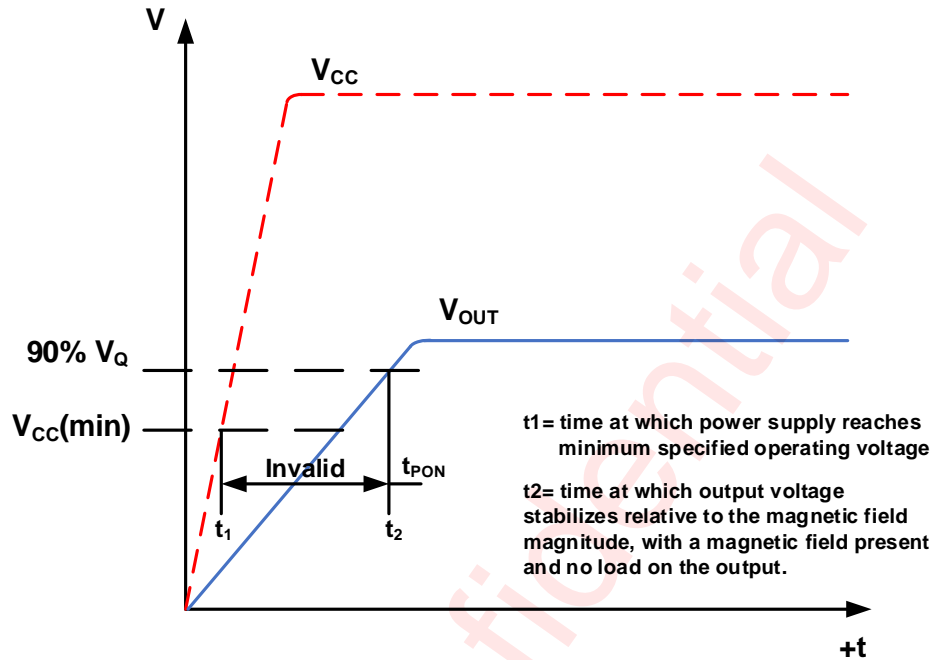

Figure 5 Definition of Power On Time, t_{PON}

Ratiometric. The devices feature ratiometric output. The quiescent voltage output and sensitivity are proportional to the ratiometric supply reference voltage. The percent ratiometric change in the quiescent voltage output is defined as:

$$\Delta V_{OUTQ(\Delta V)} = \frac{\Delta V_{OUTQ(VCC)} \div \Delta V_{OUTQ(5V)}}{V_{CC} \div 5V} \times 100\% \quad (1)$$

Linearity and Symmetry. The on-chip output stage is designed to provide a linear output with maximum supply voltage of V_{CCN} . Although application of very high magnetic fields will not damage these devices, it will force the output into a non-linear region. Linearity in percent is measured and defined as:

$$Lin+ = \frac{V_{OUT(+B)} - V_{OUTQ}}{2 \times (V_{OUT(+B/2)} - V_{OUTQ})} \times 100\% \quad (2)$$

$$Lin- = \frac{V_{OUT(-B)} - V_{OUTQ}}{2 \times (V_{OUT(-B/2)} - V_{OUTQ})} \times 100\% \quad (3)$$

and output symmetry as:

$$sym = \frac{V_{OUT(+B)} - V_{OUTQ}}{V_{OUTQ} - V_{OUT(-B)}} \times 100\% \quad (4)$$

The Parameter S_{LE} defines the linear error as the difference in sensitivity between any positive B values and any negative B values when the output is within the Output Voltage Saturation range.

$$S_{LE} = \frac{sen_+ - sen_-}{0.5 \times (sen_+ + sen_-)} \times 100\% \quad (6)$$

Tape And Reel Information

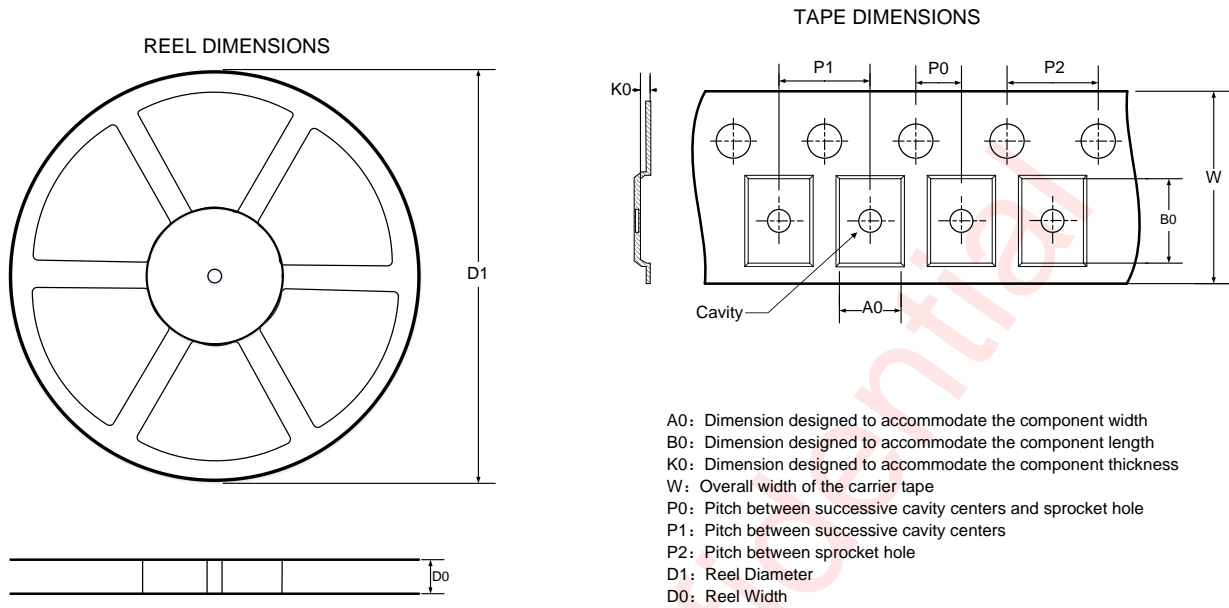

QUADRANT ASSIGNMENTS FOR PIN 1 ORIENTATION IN TAPE

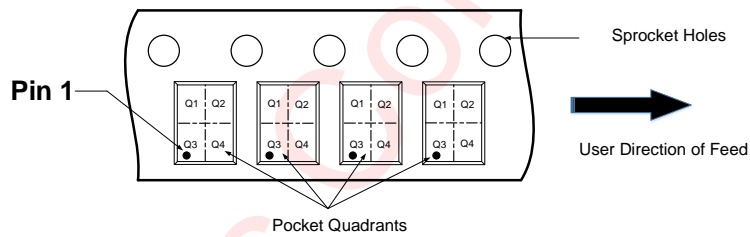

Note: The above picture is for reference only. Please refer to the value in the table below for the actual size

DIMENSIONS AND PIN1 ORIENTATION

D1 (mm)	D0 (mm)	A0 (mm)	B0 (mm)	K0 (mm)	P0 (mm)	P1 (mm)	P2 (mm)	W (mm)	Pin1 Quadrant
178.00	8.40	3.30	3.20	1.40	2.00	4.00	4.00	8.00	Q3

All dimensions are nominal

Package Description

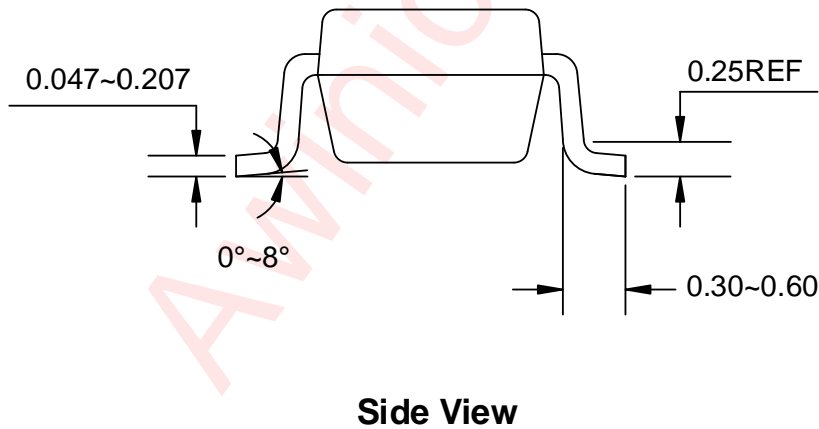
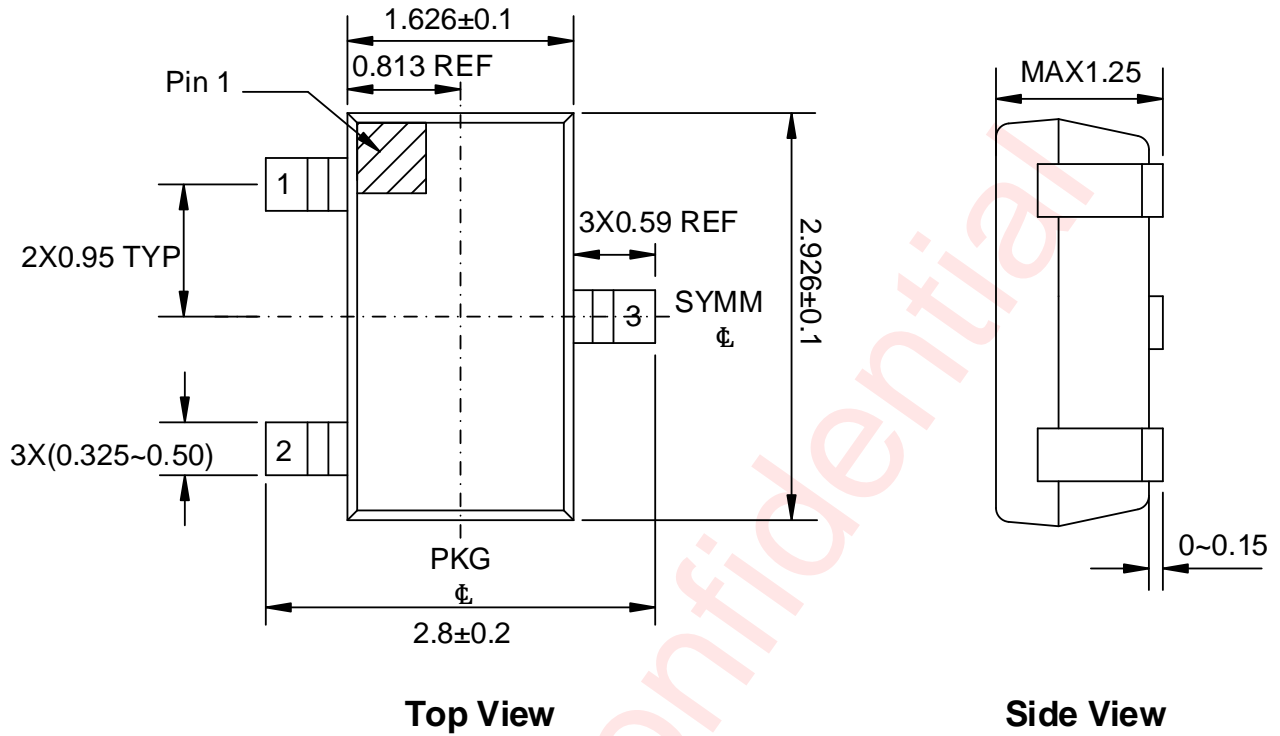

Unit: mm

Land Pattern Data

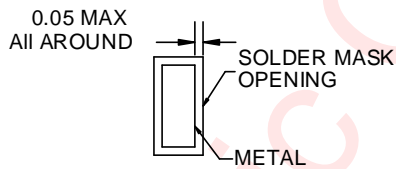
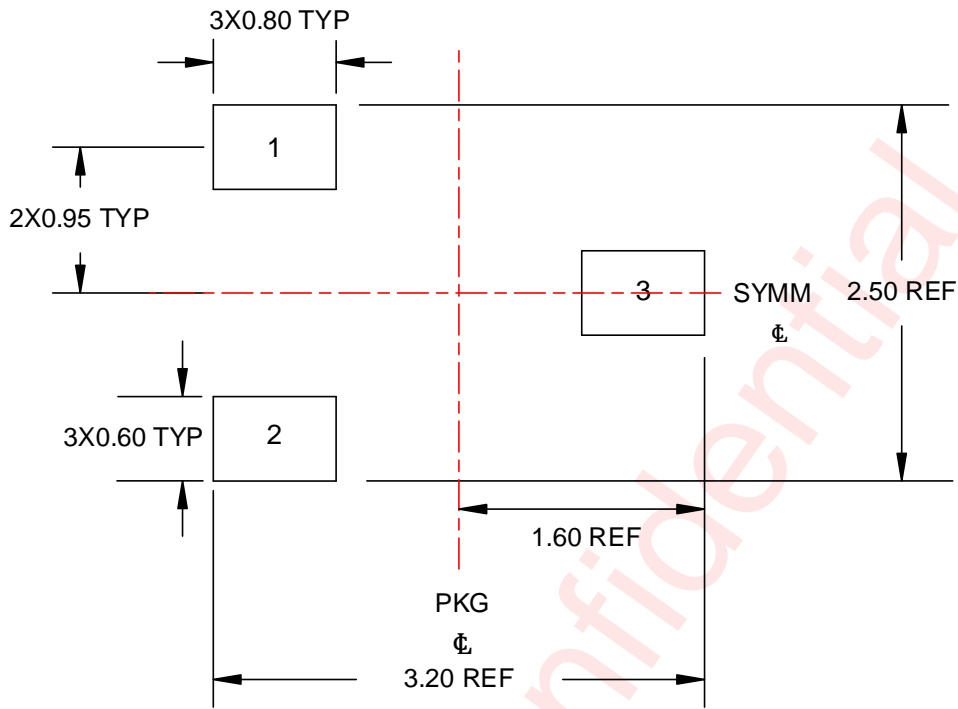

NON SOLDER MASK DEFINED

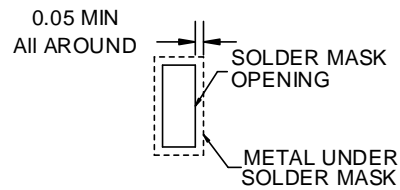

SOLDER MASK DEFINED

Unit: mm

Revision History

Version	Date	Change Record
V1.0	Dec. 2024	Initial release

Awinic Confidential

Disclaimer

All trademarks are the property of their respective owners. Information in this document is believed to be accurate and reliable. However, Shanghai AWINIC Technology Co., Ltd (AWINIC Technology) does not give any representations or warranties, expressed or implied, as to the accuracy or completeness of such information and shall have no liability for the consequences of use of such information.

AWINIC Technology reserves the right to make changes to information published in this document, including without limitation specifications and product descriptions, at any time and without notice. Customers shall obtain the latest relevant information before placing orders and shall verify that such information is current and complete. This document supersedes and replaces all information supplied prior to the publication hereof.

AWINIC Technology products are not designed, authorized or warranted to be suitable for use in medical, military, aircraft, space or life support equipment, nor in applications where failure or malfunction of an AWINIC Technology product can reasonably be expected to result in personal injury, death or severe property or environmental damage. AWINIC Technology accepts no liability for inclusion and/or use of AWINIC Technology products in such equipment or applications and therefore such inclusion and/or use is at the customer's own risk.

Applications that are described herein for any of these products are for illustrative purposes only. AWINIC Technology makes no representation or warranty that such applications will be suitable for the specified use without further testing or modification.

All products are sold subject to the general terms and conditions of commercial sale supplied at the time of order acknowledgement.

Nothing in this document may be interpreted or construed as an offer to sell products that is open for acceptance or the grant, conveyance or implication of any license under any copyrights, patents or other industrial or intellectual property rights.

Reproduction of AWINIC information in AWINIC data books or data sheets is permissible only if reproduction is without alteration and is accompanied by all associated warranties, conditions, limitations, and notices. AWINIC is not responsible or liable for such altered documentation. Information of third parties may be subject to additional restrictions.

Resale of AWINIC components or services with statements different from or beyond the parameters stated by AWINIC for that component or service voids all express and any implied warranties for the associated AWINIC component or service and is an unfair and deceptive business practice. AWINIC is not responsible or liable for any such statements.