

AW35650 7 GHz, 2:1 (SPDT) 10-Channel MIPI Switch

Features

- Supply Voltage Range(V_{CC}): 1.65 to 5.0V
- 10-Channel 2:1 Switch
- Supports Types:
 - MIPI D-PHY & C-PHY
 - General bus, such as I2C, I2S, SPI, etc
- Input Signals:
 - For MIPI PHY: 0 to 1.3V
 - For General bus: 0 to 1.8V
- R_{ON} : 7 Ω Typical
- ΔR_{ON} : 0.1 Ω Typical
- I_{CC} : 25 μ A Typical
- -3dB Bandwidth: 7 GHz Typical
- Low Crosstalk: -40 dB Typical
- Low Off Isolation: -24 dB Typical
- C_{ON} : 1.4 pF Typical

Applications

- Smartphones
- Tablets
- Laptops
- Displays

General Description

The AW35650 is a 10-Channel MIPI Switch. This single-pole double-throw switch is optimized for high speed MIPI applications. The AW35650 is designed to facilitate multiple MIPI compliant devices to connect to a CSI or DSI module.

The AW35650 is available in a WLCSP 2.43mmX2.43mmX0.488mm-36B package.

Typical Application Circuit

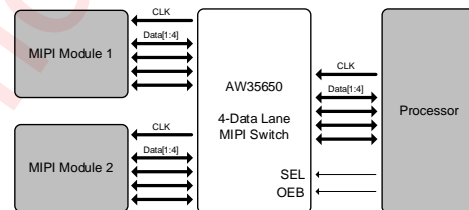

Typical Application Circuit of AW35650

All the trademarks mentioned in the document are the property of their owners.

Pin Configuration And Top Mark

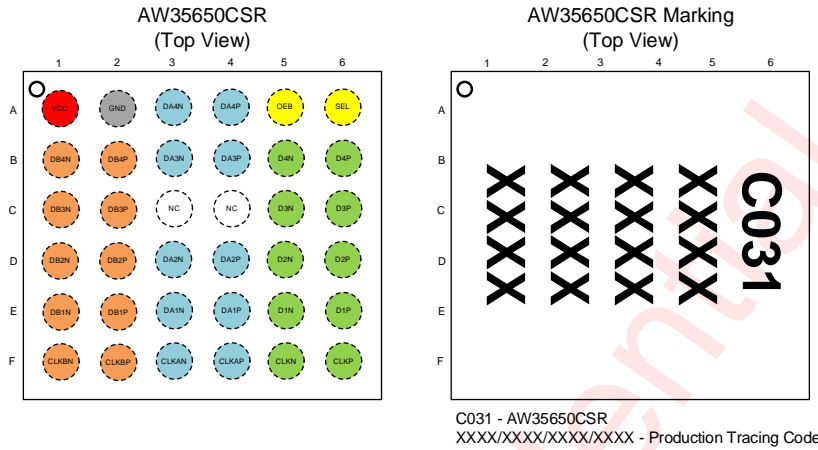

Pin Configuration and Top Mark

Pin Definition

PIN	NAME	DESCRIPTION
A1	VCC	Power supply input
A2	GND	Ground
A3	DA4N	A side data port 4, differential -
A4	DA4P	A side data port 4, differential +
A5	OEB	Output enable, active low
A6	SEL	Channel select
B1	DB4N	B side data port 4, differential -
B2	DB4P	B side data port 4, differential +
B3	DA3N	A side data port 3, differential -
B4	DA3P	A side data port 3, differential +
B5	D4N	Common data port 4, differential -
B6	D4P	Common data port 4, differential +

Pin Definition (Continued)

PIN	NAME	DESCRIPTION
C1	DB3N	B side data port 3, differential -
C2	DB3P	B side data port 3, differential +
C3	NC	No connect
C4	NC	No connect
C5	D3N	Common data port 3, differential -
C6	D3P	Common data port 3, differential +
D1	DB2N	B side data port 2, differential -
D2	DB2P	B side data port 2, differential +
D3	DA2N	A side data port 2, differential -
D4	DA2P	A side data port 2, differential +
D5	D2N	Common data port 2, differential -
D6	D2P	Common data port 2, differential +
E1	DB1N	B side data port 1, differential -
E2	DB1P	B side data port 1, differential +
E3	DA1N	A side data port 1, differential -
E4	DA1P	A side data port 1, differential +
E5	D1N	Common data port 1, differential -
E6	D1P	Common data port 1, differential +
F1	CLKBN	B side clock port, differential -
F2	CLKBP	B side clock port, differential +
F3	CLKAN	A side clock port, differential -
F4	CLKAP	A side clock port, differential +
F5	CLKN	Common clock port, differential -
F6	CLKP	Common clock port, differential +

Pin Functions

OEB	SEL	Function
H	X	Clock and Data ports High Impedance
L	L	CLKP/N=CLKAP/N, DnP/N=DAnP/N
L	H	CLKP/N=CLKBP/N, DnP/N=DBnP/N

Functional Block Diagram

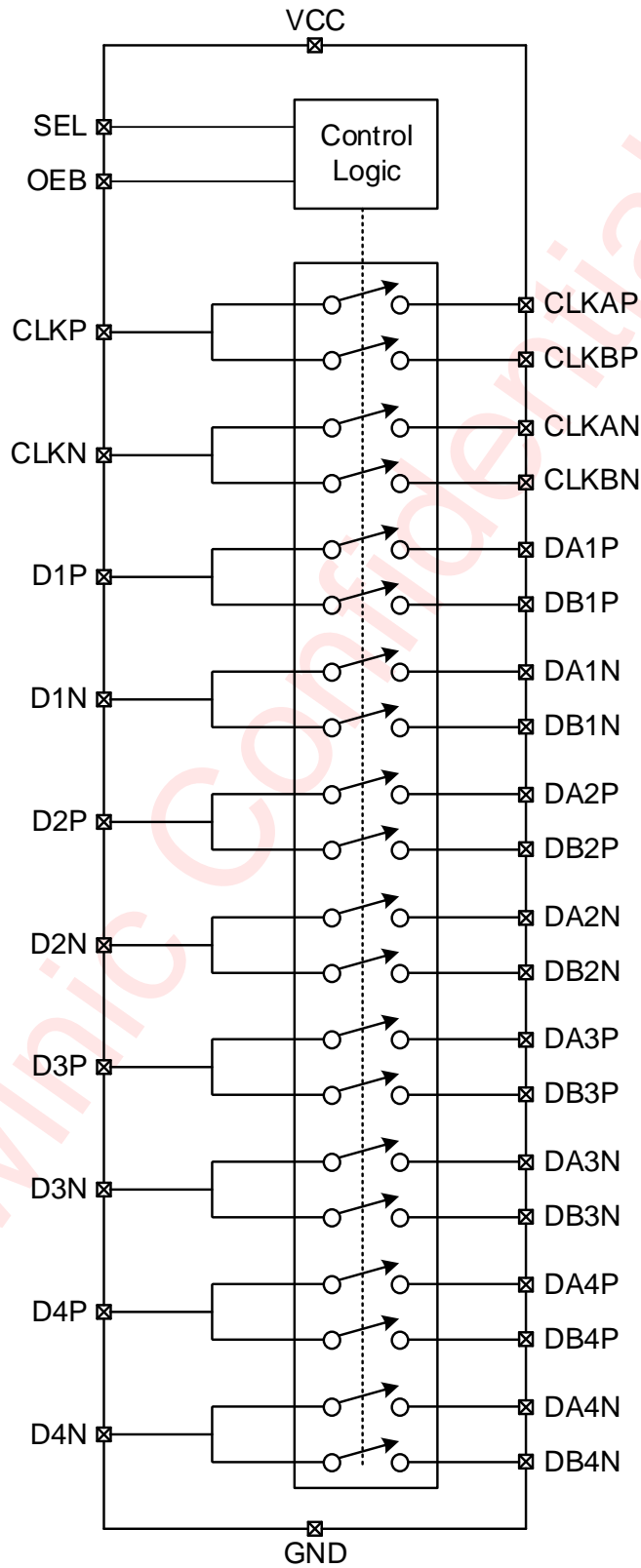

Functional Block Diagram

Typical Application Circuits

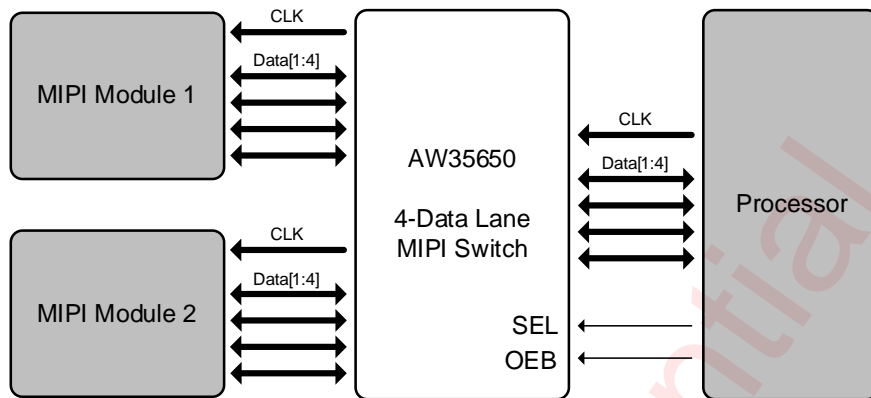

Typical Application Circuit of AW35650

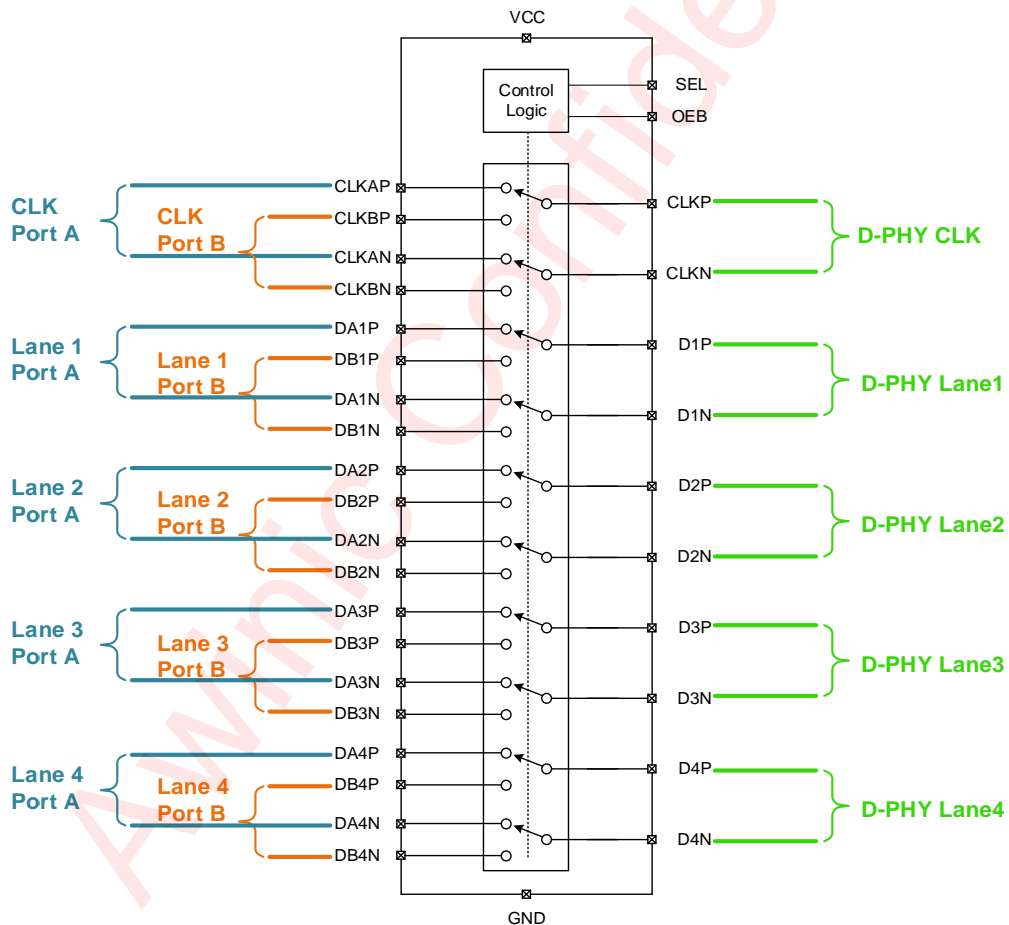

Recommended D-PHY Configuration of AW35650

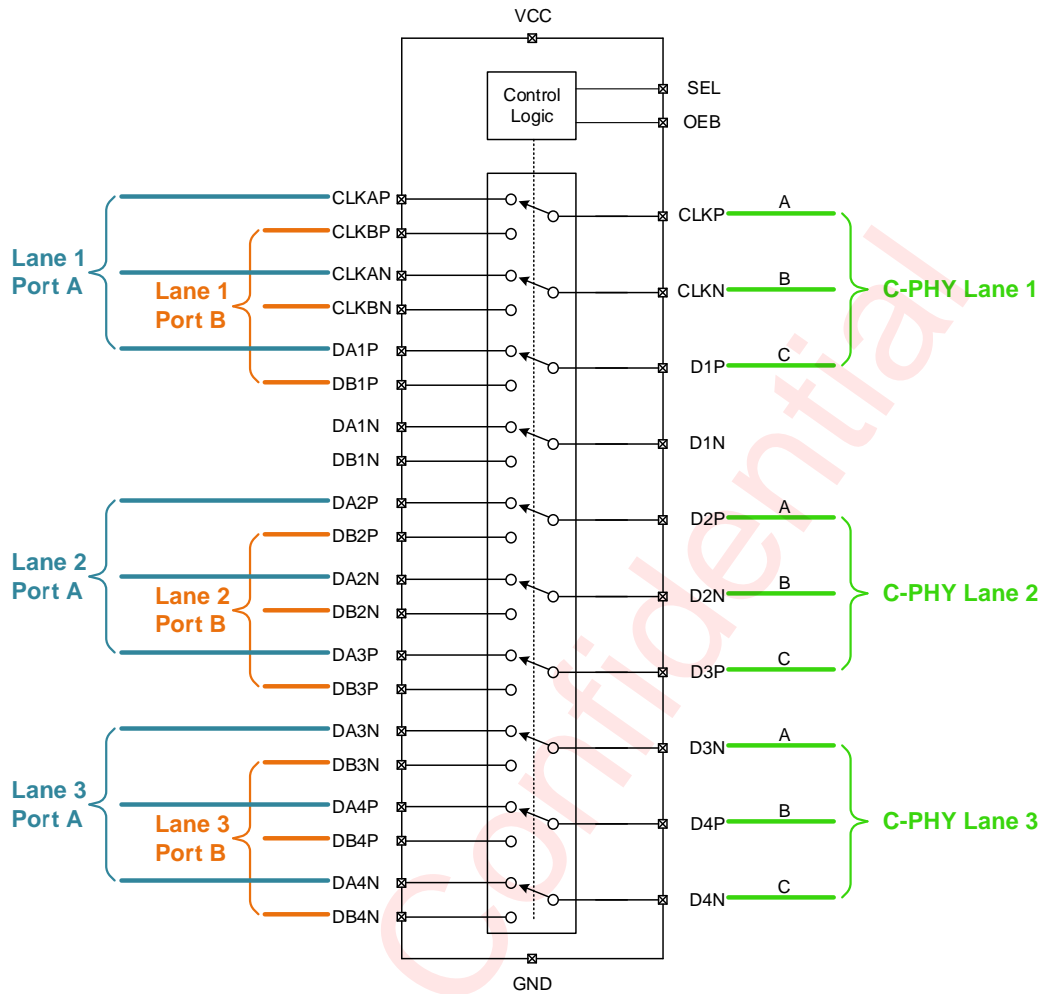

Recommended C-PHY Configuration of AW35650

The control inputs OEB, SEL must be held HIGH or LOW; they must no float.

Ordering Information

Part Number	Temperature	Package	Marking	Moisture Sensitivity Level	Environmental Information	Delivery Form
AW35650CSR	-40°C~85°C	WLCSP 2.43mmX2.43mm X0.488mm-36B	C031	MSL1	ROHS+HF	3000 units/ Tape and Reel

Absolute Maximum Ratings(NOTE1)

PARAMETERS		RANGE
Supply voltage range V_{CC}		-0.3V to 6V
Input/Output DC switch voltage V_{IO} (NOTE2)		-0.3V to 6V
Input voltage range	SEL, OEB	-0.3V to 6V
Junction-to-ambient thermal resistance θ_{JA}		61°C/W
Maximum operating junction temperature T_{JMAX}		150°C
Operating free-air temperature range		-40°C to 85°C
Storage temperature T_{STG}		-65°C to 150°C
Lead temperature (soldering 10 seconds)		260°C
ESD		
Human Body Model (All pins, per ANSI/ESDA/JEDEC JS-001-2017)		±2kV
Charged Device Model (All pins, per JESD22-C101)		±1kV
Machine Model (All pins, per JESD22-A115C)		±200V
Latch-Up		
Test condition: JESD78E		±200mA

NOTE1: Conditions out of those ranges listed in "absolute maximum ratings" may cause permanent damages to the device. In spite of the limits above, functional operation conditions of the device should within the ranges listed in "recommended operating conditions". Exposure to absolute-maximum-rated conditions for prolonged periods may affect device reliability.

NOTE2: V_{IO} refers to analog data/clock switch ports

Electrical Characteristics

T_A = -40°C to 85°C unless otherwise noted. Typical values are guaranteed for V_{CC}=3.3V T_A = 25°C.

PARAMETER		TEST CONDITION	MIN	TYP	MAX	UNIT
V _{CC}	Supply voltage		1.65	3.3	5.0	V
I _{CC}	Active supply current	OEB=0V, SEL=0 or V _{CC}		25	45	μA
I _{CC_PD}	Standby supply current	OEB=V _{CC} , SEL=0 or V _{CC}			1	μA
I _{CC_PD_1.5}	Standby supply current	V _{CC} =5V OEB=1.5V, SEL=0 or V _{CC}		1		μA
DC Characteristics						
R _{ON_HS}	On-state resistance for high speed MIPI mode	V _{I/O} =0.2V, I _{ON} =8mA V _{CC} =1.65V		7	11	Ω
		V _{I/O} =0.2V, I _{ON} =8mA V _{CC} =1.8V to 5.0V		7	11	Ω
R _{ON_LP}	On-state resistance for low power MIPI mode	V _{I/O} =1.2V, I _{ON} =8mA V _{CC} =1.65V		8	12	Ω
		V _{I/O} =1.2V, I _{ON} =8mA V _{CC} =1.8V to 5.0V		7.5	12	Ω
ΔR _{ON_HS}	On-state resistance match between channels for high speed MIPI mode	V _{I/O} =0.2V, I _{ON} =8mA		0.1		Ω
ΔR _{ON_LP}	On-state resistance match between channels for low power MIPI mode	V _{I/O} =1.2V, I _{ON} =8mA		0.1		Ω
R _{ON_FLAT_HS}	ON-state resistance flatness for high speed MIPI mode	V _{I/O} =0V to 0.3V, I _{ON} =8mA		0.9		Ω
R _{ON_FLAT_LP}	ON-state resistance flatness for low power MIPI mode	V _{I/O} =0V to 1.3V, I _{ON} =8mA		0.9		Ω
I _{OFF}	Switch off leakage current	V _{CC} =1.65V to 5.0V OEB, SEL=0V or 5.0V Dn,CLKn,DAn,CLKAn,DBn, CLKBn=0V to 1.3V	-0.5		0.5	μA
I _{ON}	Switch on leakage current	V _{CC} =1.65V to 5.0V OEB=0V, SEL=0V or 5.0V Dn,CLKn,DAn,CLKAn,DBn, CLKBn=0V to 1.3V	-0.5		0.5	μA

Electrical Characteristics (Continued)

T_A = -40°C to 85°C unless otherwise noted. Typical values are guaranteed for V_{CC}=3.3V T_A = 25°C.

PARAMETER		TEST CONDITION	MIN	TYP	MAX	UNIT
Digital Characteristics						
V _{IH}	Input logic high (SEL, OEB)	V _{CC} =1.65V to 5.0V	1.3			V
V _{IL}	Input logic low (SEL, OEB)	V _{CC} =1.65V to 5.0V			0.5	V
I _{LEAK_IN}	Input leakage (SEL, OEB)	SEL,OEB=0V to 5.0V	-0.5		0.5	μA
C _{IN}	Digital Input capacitance (SEL, OEB)	f=1MHz		5		pF
Dynamic Characteristics						
C _{ON}	ON capacitance	OEB=0V, Dn,CLKn,DAn,DBn,CLKAn, CLKBn=0V or 0.2V f = 1250 MHz, switch ON		1.4		pF
C _{OFF}	OFF capacitance	OEB=V _{CC} , Dn,CLKn,DAn,DBn,CLKAn, CLKBn=0V or 0.2V f = 1250MHz, switch OFF		1.2		pF
O _{ISO}	Differential off isolation	R _L = 50Ω, C _L = 0pF V _{I/O} =200mV+200mV _{PP} (differential) f = 1250MHz, switch OFF		-24		dB
X _{TALK}	Differential Channel to channel crosstalk	R _L = 50Ω, C _L = 0pF V _{I/O} =200mV+200mV _{PP} (differential) f = 1250MHz, switch ON		-40		dB
BW	-3dB bandwidth	R _L = 50Ω, C _L = 0pF V _{I/O} =200mV+200mV _{PP} (differential), switch ON		7		GHz
I _{LOSS}	Insertion Loss	R _L = 50Ω, C _L = 0pF V _{I/O} =200mV+200mV _{PP} (differential) f = 100KHz, switch ON		-0.34		dB

Electrical Characteristics (Continued)

T_A = -40°C to 85°C unless otherwise noted. Typical values are guaranteed for V_{CC}=3.3V T_A = 25°C.

PARAMETER		TEST CONDITION	MIN	TYP	MAX	UNIT
Dynamic Characteristics						
t _{INIT}	Initialization time (V _{CC} to output)	Dn,CLKn=0.6V DAn,DBn,CLKAn,CLKBn: R _L = 50Ω, C _L = 0pF		1.5	200	μs
t _{EN}	Device turn on time (OEB to output)	Dn,CLKn=0.6V DAn,DBn,CLKAn,CLKBn: R _L = 50Ω, C _L = 0pF		0.5	200	μs
t _{DIS}	Device turn off time (OEB to output)	Dn,CLKn=0.6V DAn,DBn,CLKAn,CLKBn: R _L = 50Ω, C _L = 0pF		150	250	ns
t _{ON}	Switch turn on time (SEL to output)	Dn,CLKn=0.6V DAn,DBn,CLKAn,CLKBn: R _L = 50Ω, C _L = 0pF		800	1600	ns
t _{OFF}	Switch turn off time (SEL to output)	Dn,CLKn=0.6V DAn,DBn,CLKAn,CLKBn: R _L = 50Ω, C _L = 0pF		150	800	ns
t _{BBM}	Break before make time	Dn,CLKn: R _L = 50Ω, C _L = 0pF DAn,DBn,CLKAn,CLKBn =0.6V		400		ns
t _{PD}	Propagation delay	Dn,CLKn=0.6V DAn,DBn,CLKAn,CLKBn: R _L = 50Ω, C _L = 0pF		67		ps
t _{SKEW(INTRA)}	Intrapair skew	Dn,CLKn=0.3V DAn,DBn,CLKAn,CLKBn: R _L = 50Ω, C _L = 0pF		6		ps
t _{SKEW(INTER)}	Interpair skew	Dn,CLKn=0.3V DAn,DBn,CLKAn,CLKBn: R _L = 50Ω, C _L = 0pF		6		ps

Detailed Functional Description

The AW35650 is a four-data-lane MIPI D-PHY switch. This device is an optimized 10-channel (5 differential) single-pole, double-throw switch for use in high speed applications. The AW35650 is designed to facilitate multiple MIPI compliant devices to connect to a single CSI/DSI, C-PHY/D-PHY module.

High Impedance Mode

When OEB is logic high, the AW35650 is in high impedance mode, all the clock and data ports are in Hi-Z state.

OEB	SEL	Function
H	X	Clock and Data ports High Impedance
L	L	CLKP/N=CLKAP/N, DnP/N=DAnP/N
L	H	CLKP/N=CLKBP/N, DnP/N=DBnP/N

Parameter Measurement Information

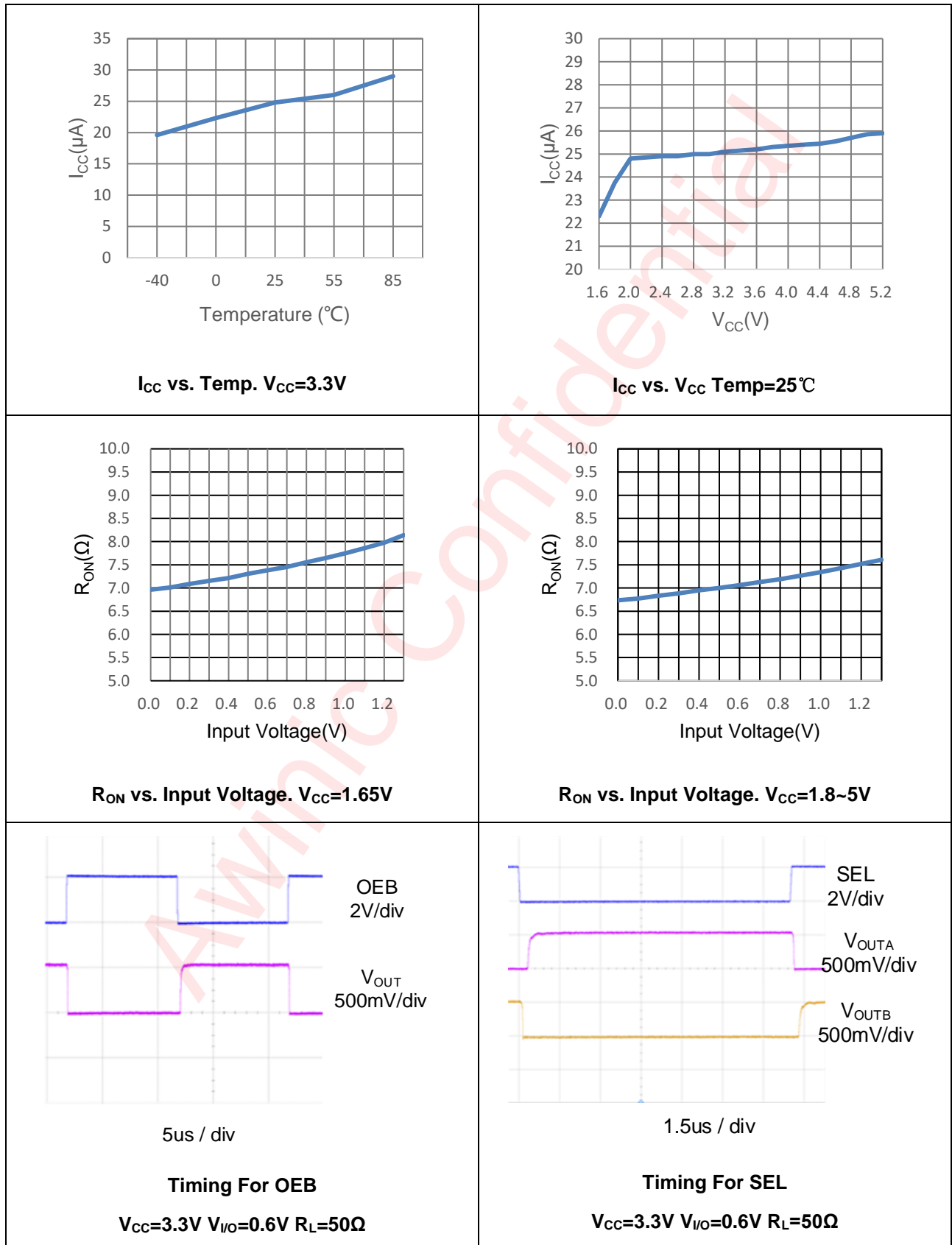

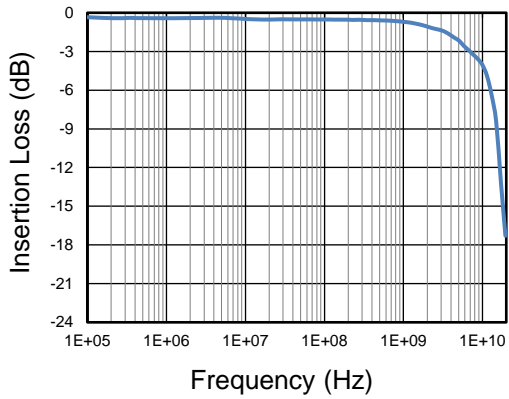

Differential Bandwidth

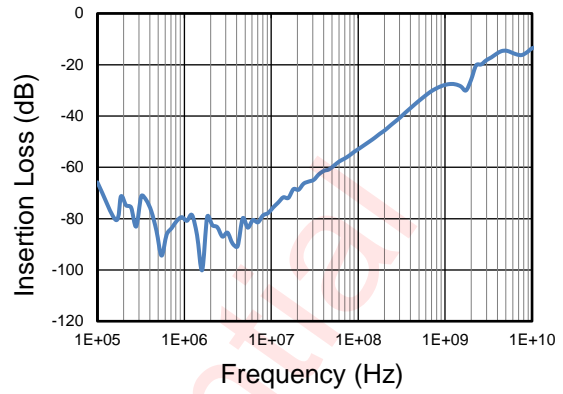

Off Isolation

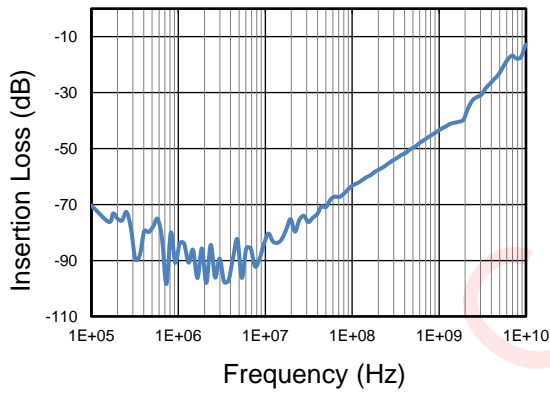

Differential Crosstalk

Confidential

Parameter Measurement Information

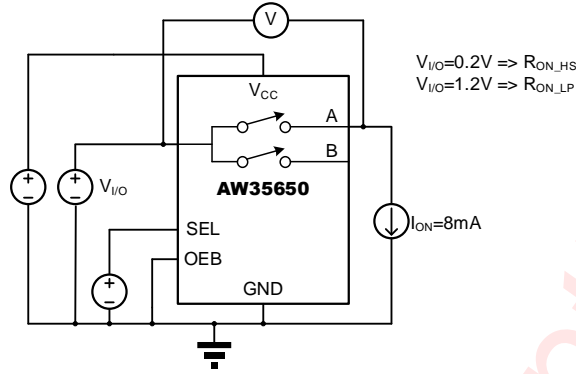

On Resistance

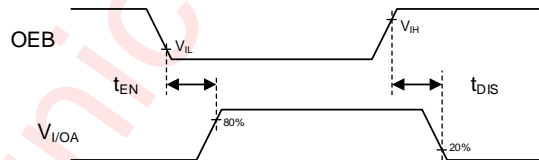
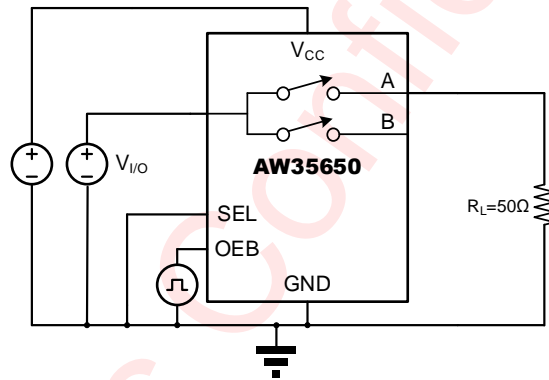

t_{EN} and t_{DIS} Timing For OEB

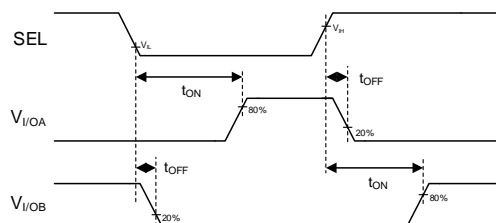
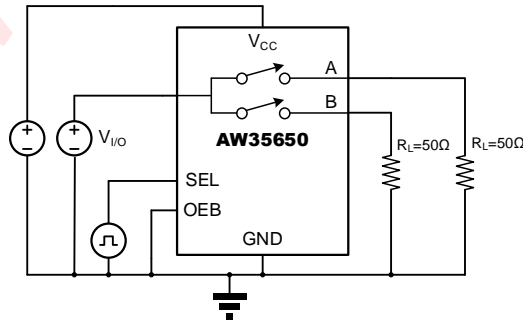

t_{ON} and t_{OFF} Timing For SEL

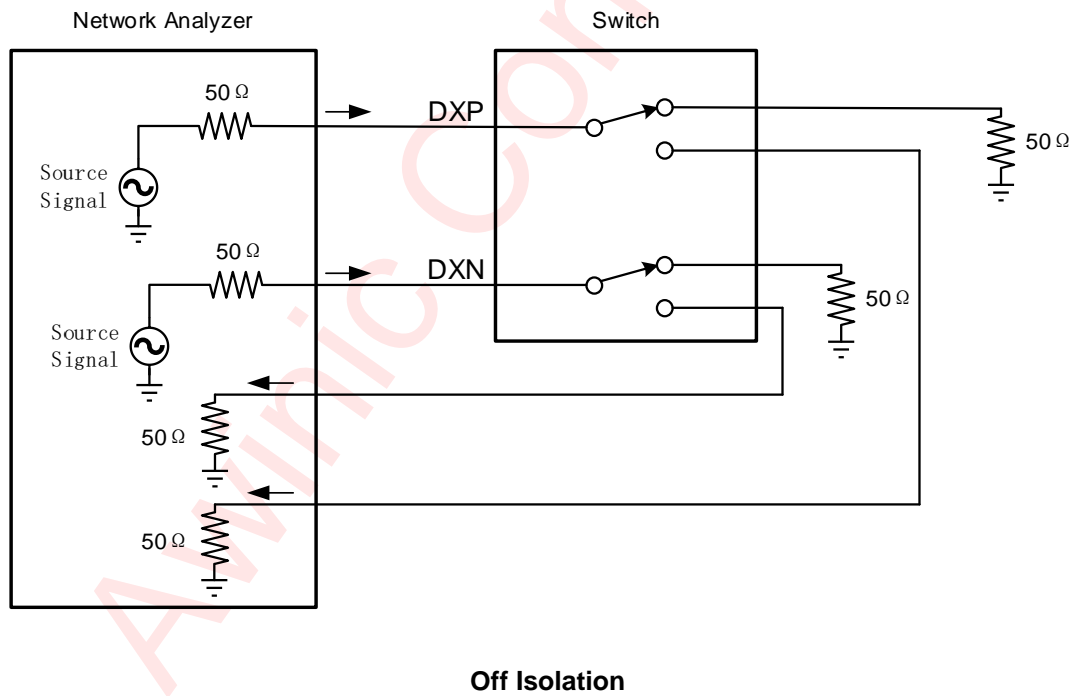
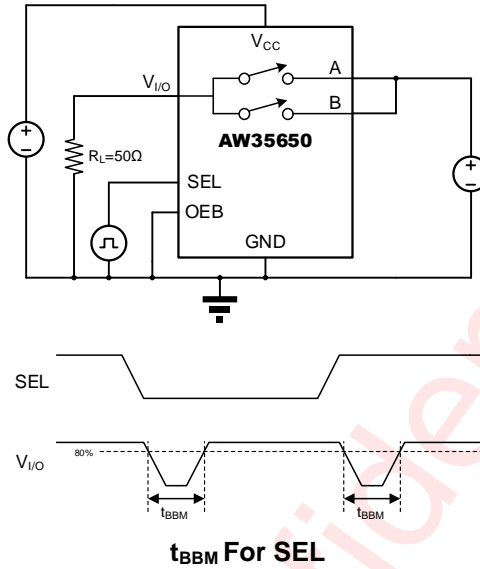

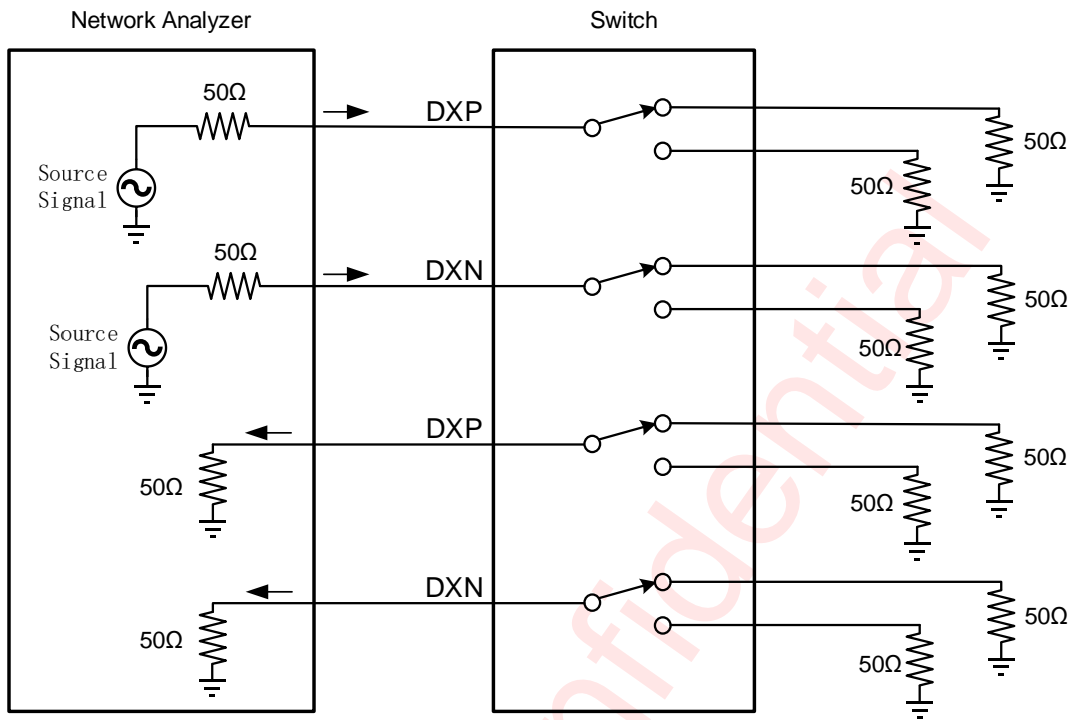

Crosstalk

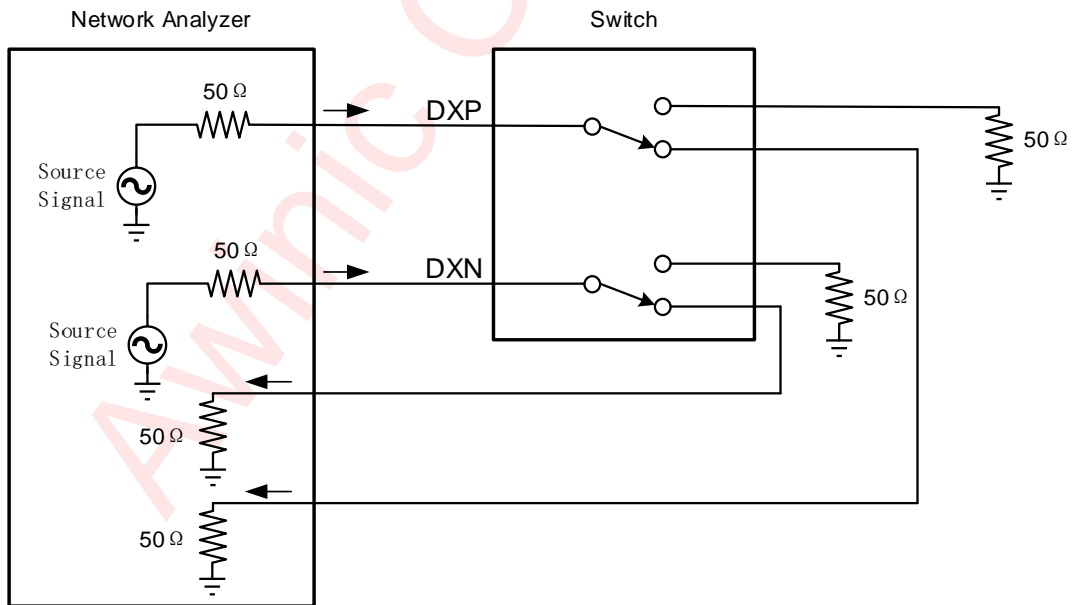

Bandwidth and Insertion Loss

PCB Layout Consideration

To obtain the optimal performance of AW35650, PCB layout should be considered carefully. Here are some guidelines:

1. Place supply bypass capacitors as close to V_{CC} and GND pin as possible and avoid placing the bypass capacitors near the high-speed traces.
2. The characteristic impedance of the traces must match that of the receiver and transmitter to maintain signal integrity.
3. Route the high-speed signals using a minimum amount of vias and corners which reduces signal reflections and impedance changes. When it becomes necessary to make the traces turn 90° , use an arc instead of making a single 90° turn.
4. Do not route high-speed traces under or near crystals, oscillators, clock signal generators, switching regulators, mounting holes, magnetic devices or ICs that use or duplicate clock signals.
5. Avoid stubs on the high-speed signal lines because they cause signal reflections.
6. Route all high-speed signal traces over continuous GND planes, with no interruptions.
7. High speed signal traces must be length matched as much as possible to minimize skew between data and clock lines. Width and spacing between differential traces must be equal line width and line spacing

Tape And Reel Information

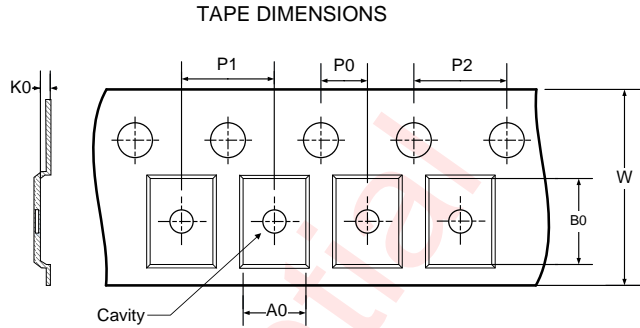
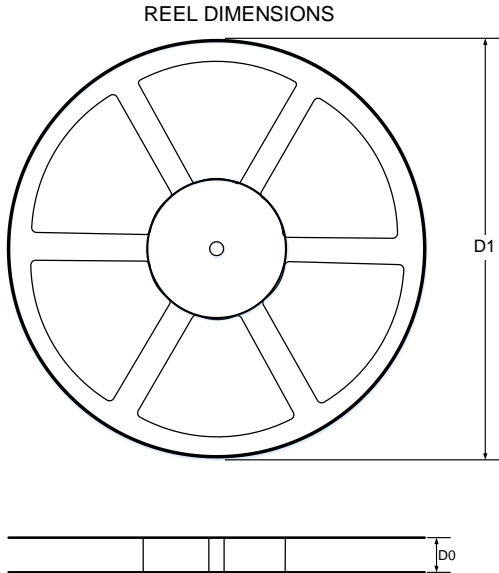

- A0: Dimension designed to accommodate the component width
- B0: Dimension designed to accommodate the component length
- K0: Dimension designed to accommodate the component thickness
- W: Overall width of the carrier tape
- P0: Pitch between successive cavity centers and sprocket hole
- P1: Pitch between successive cavity centers
- P2: Pitch between sprocket hole
- D1: Reel Diameter
- D0: Reel Width

QUADRANT ASSIGNMENTS FOR PIN 1 ORIENTATION IN TAPE

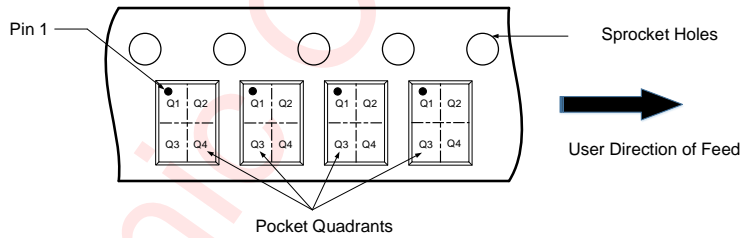

All Dimensions are nominal

D1 (mm)	D0 (mm)	A0 (mm)	B0 (mm)	K0 (mm)	P0 (mm)	P1 (mm)	P2 (mm)	W (mm)	Pin1 Quadrant
179.00	9.00	2.54	2.54	0.76	2.00	4.00	4.00	8.00	Q1

Package Description

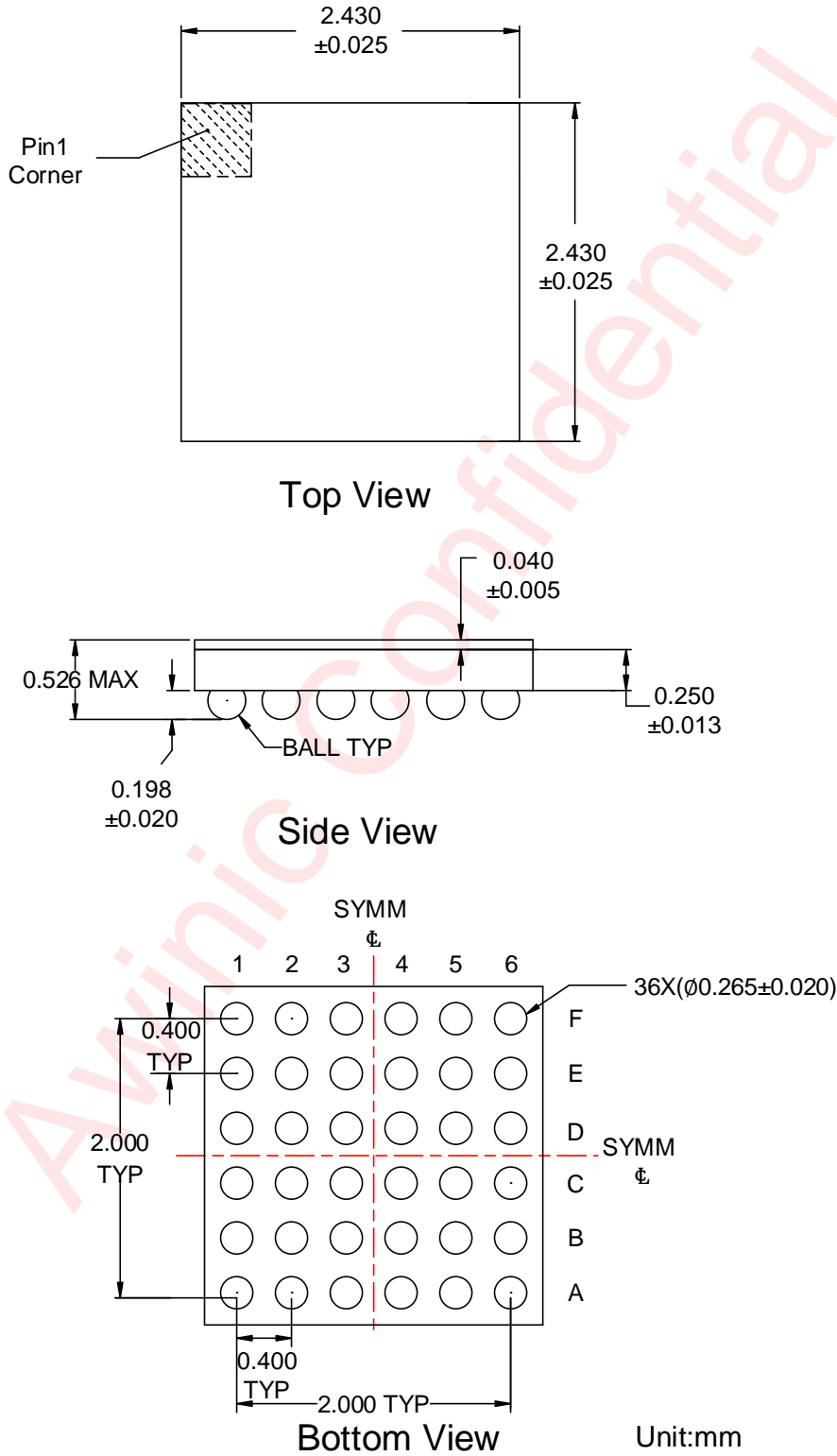

Land Pattern Data

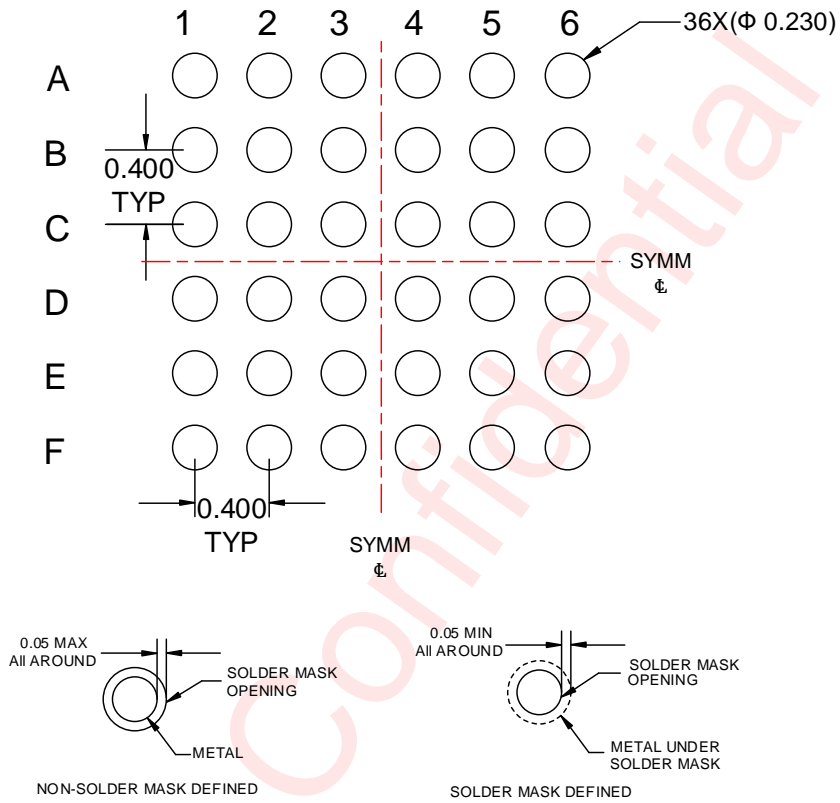

Unit: mm

Revision History

Version	Date	Change Record
V1.0	Mar.2019	1. Datasheet V1.0 released.

Awinic Confidential

Disclaimer

Information in this document is believed to be accurate and reliable. However, Shanghai AWINIC Technology Co., Ltd (AWINIC Technology) does not give any representations or warranties, expressed or implied, as to the accuracy or completeness of such information and shall have no liability for the consequences of use of such information.

AWINIC Technology reserves the right to make changes to information published in this document, including without limitation specifications and product descriptions, at any time and without notice. Customers shall obtain the latest relevant information before placing orders and shall verify that such information is current and complete. This document supersedes and replaces all information supplied prior to the publication hereof.

AWINIC Technology products are not designed, authorized or warranted to be suitable for use in medical, military, aircraft, space or life support equipment, nor in applications where failure or malfunction of an AWINIC Technology product can reasonably be expected to result in personal injury, death or severe property or environmental damage. AWINIC Technology accepts no liability for inclusion and/or use of AWINIC Technology products in such equipment or applications and therefore such inclusion and/or use is at the customer's own risk.

Applications that are described herein for any of these products are for illustrative purposes only. AWINIC Technology makes no representation or warranty that such applications will be suitable for the specified use without further testing or modification.

All products are sold subject to the general terms and conditions of commercial sale supplied at the time of order acknowledgement.

Nothing in this document may be interpreted or construed as an offer to sell products that is open for acceptance or the grant, conveyance or implication of any license under any copyrights, patents or other industrial or intellectual property rights.

Reproduction of AWINIC information in AWINIC data books or data sheets is permissible only if reproduction is without alteration and is accompanied by all associated warranties, conditions, limitations, and notices. AWINIC is not responsible or liable for such altered documentation. Information of third parties may be subject to additional restrictions.

Resale of AWINIC components or services with statements different from or beyond the parameters stated by AWINIC for that component or service voids all express and any implied warranties for the associated AWINIC component or service and is an unfair and deceptive business practice. AWINIC is not responsible or liable for any such statements.