

## 1. General Description

---

The EM74HC14 and EM74HCT14 are hex inverter with Schmitt-trigger inputs. This device features reduced input threshold levels to allow interfacing to TTL logic levels. Schmitt trigger inputs transform slowly changing input signals into sharply defined jitter-free output signals.

## 2. Features and Benefits

---

- Wide supply voltage range from 2.0 V to 6.0 V
- High noise immunity
- CMOS low power dissipation
- Latch-up performance exceeds 250 mA
- Unlimited rise and fall times
- Complies with JEDEC standards:
  - JESD8C (2.7 V to 3.6 V)
  - JESD7A (2.0 V to 6.0 V)
- ESD protection:
  - HBM ANSI/ESDA/JEDEC JS-001 Class 2 exceeds 3500 V
  - CDM ANSI/ESDA/JEDEC JS-002 Class C3 exceeds 2000 V
- Multiple package options

## EM74HC14; EM74HCT14

Hex inverting Schmitt trigger

### 3. Ordering Information

Table 1. Ordering information

Type number	Topside marking	Package		
		Name	Description	Quantity
EM74HC14D	HC14 XYYWW	SOP-14L	plastic small outline package; 14 leads; body width 3.9 mm	3000
EM74HCT14D	HCT14 XYYWW			
EM74HC14PW	HC14 XYYWW	TSSOP-14L	plastic thin shrink small outline package; 14 leads; body width 4.4 mm	3000
EM74HCT14PW	HCT14 XYYWW			

#### MARKING INFORMATION

NOTE: XYYWW = Vendor Code and Date Code.

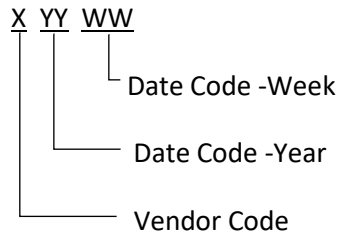

### 4. Function Diagram

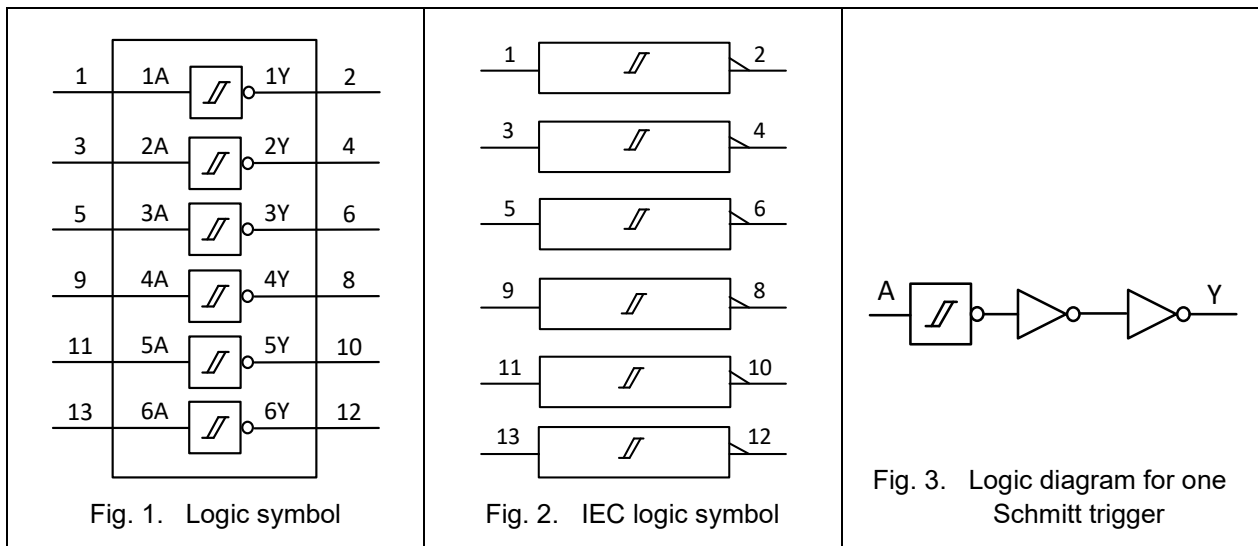

## 5. Pinning Information

### 5.1. Pinning

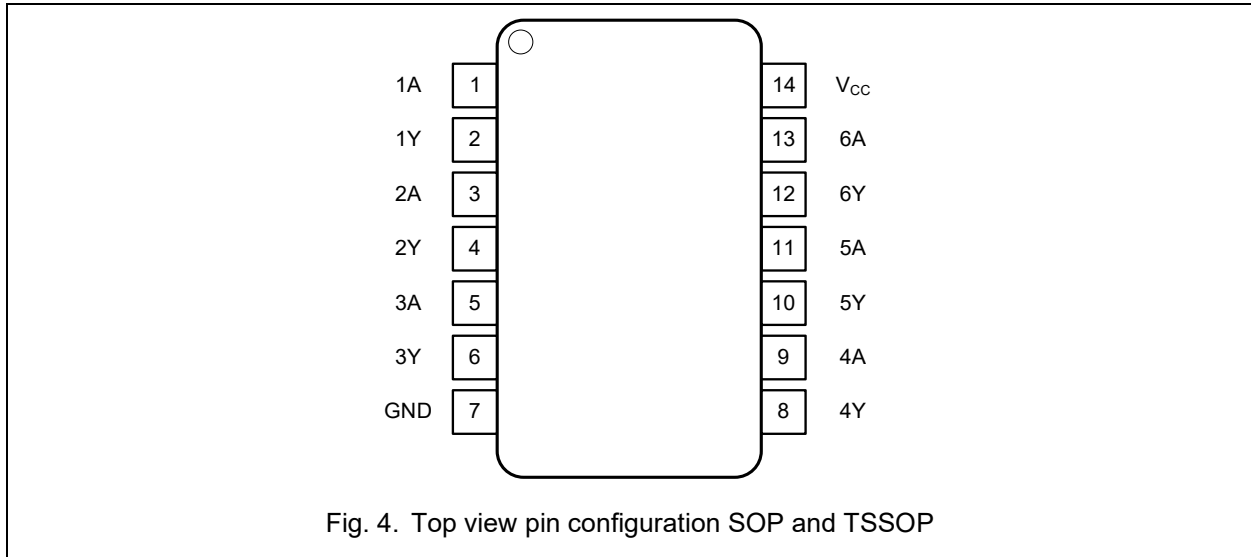

### 5.2. Pin description

Table 2. Pin description

Symbol	Pin	Description
1A, 2A, 3A, 4A, 5A, 6A	1, 3, 5, 9, 11, 13	Data input
1Y, 2Y, 3Y, 4Y, 5Y, 6Y	2, 4, 6, 8, 10, 12	Data output
GND	7	Ground (0V)
V <sub>cc</sub>	14	Supply voltage

## 6. Functional Description

Table 3. Function table

H = HIGH voltage level; L = LOW voltage level.

Input	Output
nA	nY
L	H
H	L

## 7. Absolute Maximum Ratings

Stresses exceeding the absolute maximum ratings may damage the device. The device may not function or be operable above the recommended operating conditions and stressing the parts to these levels is not recommended. In addition, extended exposure to stresses above the recommended operating conditions may affect device reliability. The absolute maximum ratings are stress ratings only.

**Table 4. Absolute Maximum Ratings**

In accordance with the Absolute Maximum Rating System (IEC 60134). Voltages are referenced to GND.

Symbol	Parameter	Conditions	Min	Max	Unit
V <sub>CC</sub>	supply voltage		-0.5	7.0	V
I <sub>IK</sub>	input clamping current	V <sub>I</sub> < -0.5 V or V <sub>I</sub> > V <sub>CC</sub> + 0.5 V [1]		±20	mA
I <sub>OK</sub>	output clamping current	V <sub>O</sub> < -0.5 V or V <sub>O</sub> > V <sub>CC</sub> + 0.5 V [1]		±20	mA
I <sub>O</sub>	output current	V <sub>O</sub> = -0.5 V to (V <sub>CC</sub> + 0.5 V)		±25	mA
I <sub>CC</sub>	supply current			50	mA
I <sub>GND</sub>	ground current		-50		mA
P <sub>tot</sub>	total power dissipation			500	mW
T <sub>stg</sub>	storage temperature		-65	150	°C

[1] The input and output voltage ratings may be exceeded if the input and output current ratings are observed.

## 8. Recommended Operating Conditions

The Recommended Operating Conditions table defines the conditions for actual device operation. Recommended operating conditions are specified to ensure optimal performance to the datasheet specifications. EnergyMath does not recommend exceeding them or designing to Absolute Maximum Ratings.

**Table 5. Recommended Operating Conditions**

Symbol	Parameter	Conditions	EM74HC14			EM74HCT14			Unit
			Min	Typ	Max	Min	Typ	Max	
V <sub>CC</sub>	supply voltage		2.0	5.0	6.0	4.5	5.0	5.5	V
V <sub>I</sub>	input voltage		0		V <sub>CC</sub>	0		V <sub>CC</sub>	V
V <sub>O</sub>	output voltage		0		V <sub>CC</sub>	0		V <sub>CC</sub>	V
T <sub>amb</sub>	ambient temperature		-40		125	-40		125	°C

## 9. Static Characteristics

**Table 6. Static characteristics**

At recommended operating conditions. Voltages are referenced to GND (ground = 0 V). Typical values measured at  $T_{amb} = 25^{\circ}\text{C}$  (unless otherwise noted)

Symbol	Parameter	Conditions	-40 °C to +85 °C			-40 °C to +125 °C		Unit
			Min	Typ	Max	Min	Max	
<b>EM74HC14</b>								
$V_{OH}$	HIGH-level output voltage	$V_I = V_{T+}$ or $V_{T-}$						
		$I_O = -20 \mu\text{A}; V_{CC} = 2.0 \text{ V}$	1.9			1.9		V
		$I_O = -20 \mu\text{A}; V_{CC} = 4.5 \text{ V}$	4.4			4.4		V
		$I_O = -20 \mu\text{A}; V_{CC} = 6.0 \text{ V}$	5.9			5.9		V
		$I_O = -4.0 \text{ mA}; V_{CC} = 4.5 \text{ V}$	3.84			3.7		V
		$I_O = -5.2 \text{ mA}; V_{CC} = 6.0 \text{ V}$	5.34			5.2		V
$V_{OL}$	LOW-level output voltage	$V_I = V_{T+}$ or $V_{T-}$						
		$I_O = 20 \mu\text{A}; V_{CC} = 2.0 \text{ V}$			0.1		0.1	V
		$I_O = 20 \mu\text{A}; V_{CC} = 4.5 \text{ V}$			0.1		0.1	V
		$I_O = 20 \mu\text{A}; V_{CC} = 6.0 \text{ V}$			0.1		0.1	V
		$I_O = 4.0 \text{ mA}; V_{CC} = 4.5 \text{ V}$			0.33		0.4	V
		$I_O = 5.2 \text{ mA}; V_{CC} = 6.0 \text{ V}$			0.33		0.4	V
$I_I$	input leakage current	$V_I = V_{CC}$ or GND ; $V_{CC} = 6.0 \text{ V}$			$\pm 1$		$\pm 1$	$\mu\text{A}$
$I_{CC}$	supply current	$V_I = V_{CC}$ or GND ; $I_O = 0 \text{ A}$ ; $V_{CC} = 6.0 \text{ V}$			20		40	$\mu\text{A}$
$C_i$	input capacitance			7				pF

## EM74HC14; EM74HCT14

Hex inverting Schmitt trigger

Symbol	Parameter	Conditions	-40 °C to +85 °C			-40 °C to +125 °C		Unit
			Min	Typ	Max	Min	Max	
<b>EM74HCT14</b>								
V <sub>OH</sub>	HIGH-level output voltage	V <sub>I</sub> = V <sub>T+</sub> or V <sub>T-</sub> ; V <sub>CC</sub> = 4.5 V						
		I <sub>O</sub> = -20 μA;	4.4			4.4		V
		I <sub>O</sub> = -4.0 mA;	3.84			3.7		V
V <sub>OL</sub>	LOW-level output voltage	V <sub>I</sub> = V <sub>T+</sub> or V <sub>T-</sub> ; V <sub>CC</sub> = 4.5 V						
		I <sub>O</sub> = 20 μA;			0.1		0.1	V
		I <sub>O</sub> = 4.0 mA;			0.33		0.4	V
I <sub>I</sub>	input leakage current	V <sub>I</sub> = V <sub>CC</sub> or GND ; V <sub>CC</sub> = 5.5 V			±1		±1	μA
I <sub>CC</sub>	supply current	V <sub>I</sub> = V <sub>CC</sub> or GND; I <sub>O</sub> = 0 A; V <sub>CC</sub> = 5.5 V			20		40	μA
ΔI <sub>CC</sub>	additional supply current	per pin ; V <sub>I</sub> = V <sub>CC</sub> - 2.1 V; I <sub>O</sub> = 0 A; other inputs at V <sub>CC</sub> or GND; V <sub>CC</sub> = 4.5 V to 5.5 V			1.55		1.85	mA
C <sub>I</sub>	input capacitance			10				pF

## 10. Dynamic Characteristics

**Table 7. Dynamic characteristics**

Voltages are referenced to GND (ground = 0 V); for test circuit see Fig. 6. Typical values measured at  $T_{amb} = 25^{\circ}\text{C}$  (unless otherwise noted).

Symbol	Parameter	Conditions	-40 °C to +85 °C			-40 °C to +125 °C		Unit
			Min	Typ	Max	Min	Max	
<b>EM74HC14</b>								
$t_{pd}$	propagation delay	nA to nY; see Fig. 5 [1]						
		$V_{CC} = 2.0\text{ V}$			35		40	ns
		$V_{CC} = 4.5\text{ V}$			20		25	ns
		$V_{CC} = 6.0\text{ V}$			15		20	ns
$t_t$	transition time	see Fig. 5 [2]						
		$V_{CC} = 2.0\text{ V}$			9		11	ns
		$V_{CC} = 4.5\text{ V}$			6		8	ns
		$V_{CC} = 6.0\text{ V}$			4		5	ns
$C_{PD}$	power dissipation capacitance	$C_L = 15\text{ pF}$ ; $f = 1\text{ MHz}$ ; $V_I = \text{GND to } V_{CC}$ [3]		18				pF
<b>EM74HCT14</b>								
$t_{pd}$	propagation delay	nA to nY; $V_{CC} = 4.5\text{ V}$ ; see Fig. 5 [1]			16		19	ns
$t_t$	transition time	$V_{CC} = 4.5\text{ V}$ ; see Fig. 5 [2]			6		8	ns
$C_{PD}$	power dissipation capacitance	$C_L = 15\text{ pF}$ ; $f = 1\text{ MHz}$ ; $V_I = \text{GND to } (V_{CC} - 1.5\text{ V})$ [3]		37				pF

[1]  $t_{pd}$  is the same as  $t_{PHL}$  and  $t_{PLH}$ .

[2]  $t_t$  is the same as  $t_{THL}$  and  $t_{TLH}$ .

[3]  $C_{PD}$  is used to determine the dynamic power dissipation ( $P_D$  in  $\mu\text{W}$ ).

$P_D = C_{PD} \times V_{CC}^2 \times f_i \times N + \Sigma(C_L \times V_{CC}^2 \times f_o)$  where:

$f_i$  = input frequency in MHz;

$f_o$  = output frequency in MHz;

$C_L$  = output load capacitance in pF;

$V_{CC}$  = supply voltage in V;

$N$  = number of inputs switching;

$\Sigma(C_L \times V_{CC}^2 \times f_o)$  = sum of outputs.

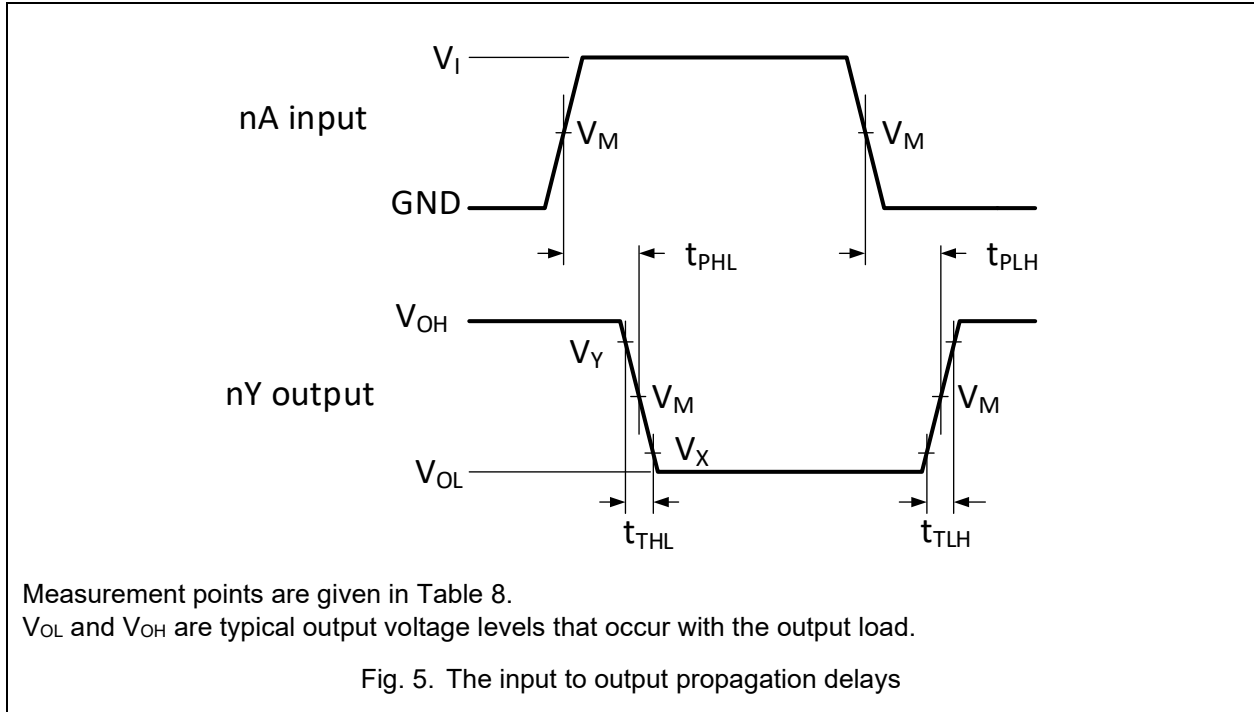
**10.1. Waveforms and test circuit**

**Table 8. Measurement points**

Type	Input	Output		
	$V_M$	$V_M$	$V_X$	$V_Y$
EM74HC14	$0.5V_{CC}$	$0.5V_{CC}$	$0.1V_{CC}$	$0.9V_{CC}$
EM74HCT14	1.3 V	1.3 V	$0.1V_{CC}$	$0.9V_{CC}$

# EM74HC14; EM74HCT14

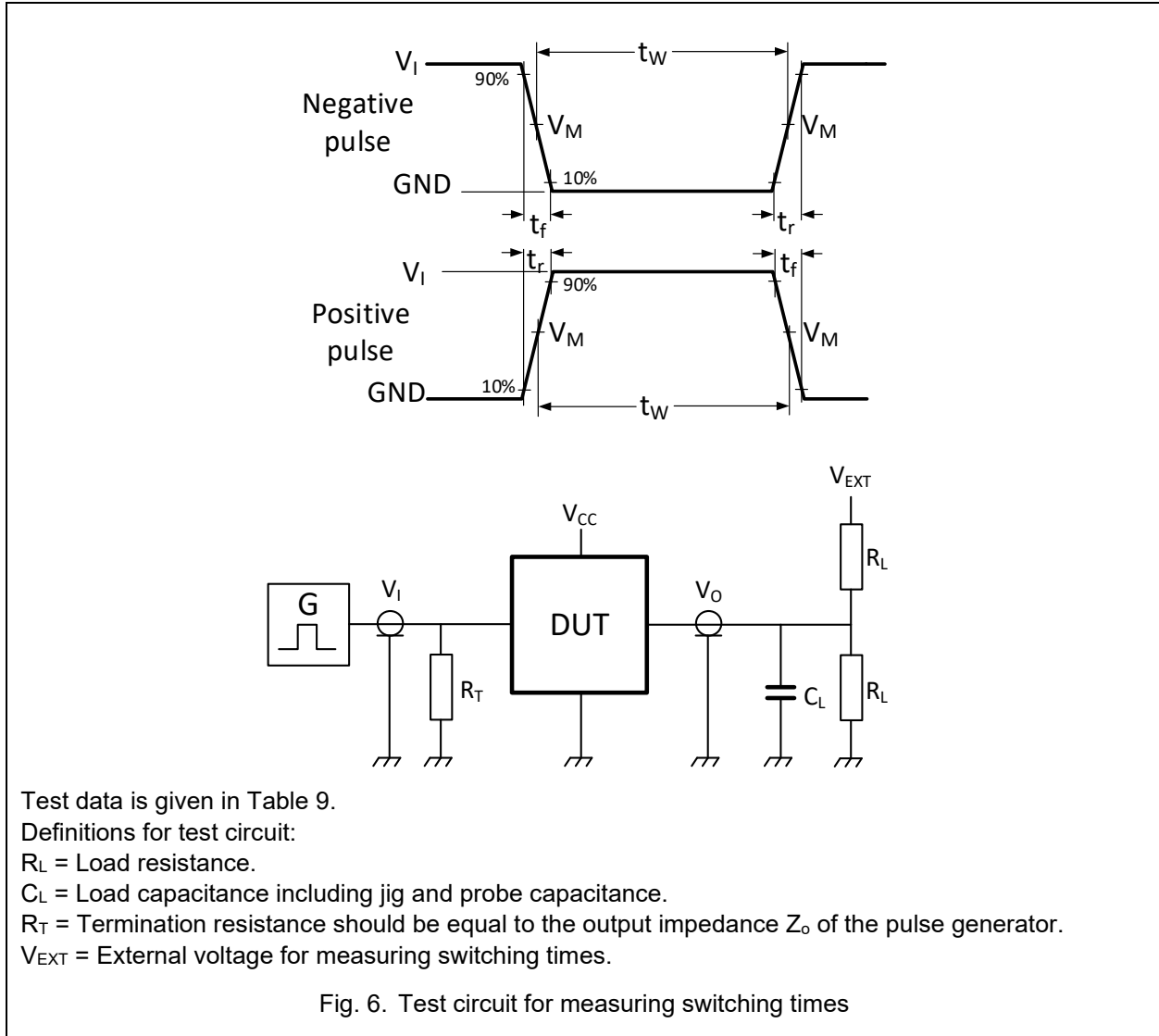
## Hex inverting Schmitt trigger



**Table 9. Test data**

Type	Input		Load		$V_{EXT}$
	$V_I$	$t_r = t_f$	$C_L$	$R_L$	$t_{PLH}, t_{PHL}$
EM74HC14	$V_{CC}$	$\leq 2.5 \text{ ns}$	15 pF	500Ω	open
EM74HCT14	3 V	$\leq 2.5 \text{ ns}$	15 pF	500Ω	open

# 11. Transfer Characteristics

**Table 10. Transfer characteristics**

At recommended operating conditions. Voltages are referenced to GND (ground = 0 V). Typical values are measured at  $T_{amb} = 25^{\circ}\text{C}$ .

Symbol	Parameter	Conditions	-40 °C to +85 °C			-40 °C to +125 °C		Unit
			Min	Typ	Max	Min	Max	
<b>EM74HC14</b>								
$V_{T+}$	positive-going threshold voltage	see Fig. 7 and Fig. 8						
		$V_{CC} = 2.0\text{ V}$	0.7	1.21	1.5	0.7	1.5	V
		$V_{CC} = 3.3\text{ V}$	1.2	1.83	2.1	1.2	2.1	V
		$V_{CC} = 4.5\text{ V}$	1.7	2.39	3.15	1.7	3.15	V
		$V_{CC} = 6.0\text{ V}$	2.1	3.05	4.2	2.1	4.2	V
$V_{T-}$	negative-going threshold voltage	see Fig. 7 and Fig. 8						V
		$V_{CC} = 2.0\text{ V}$	0.3	0.6	0.9	0.3	0.9	V
		$V_{CC} = 3.3\text{ V}$	0.66	1.04	1.5	0.66	1.5	V
		$V_{CC} = 4.5\text{ V}$	0.9	1.41	2.0	0.9	2.0	V
		$V_{CC} = 6.0\text{ V}$	1.2	1.9	2.6	1.2	2.6	V
$V_H$	hysteresis voltage	see Fig. 7 and Fig. 8						
		$V_{CC} = 2.0\text{ V}$	0.2	0.61	1.0	0.2	1.0	V
		$V_{CC} = 3.3\text{ V}$	0.3	0.79	1.3	0.3	1.3	V
		$V_{CC} = 4.5\text{ V}$	0.4	0.97	1.4	0.4	1.4	V
		$V_{CC} = 6.0\text{ V}$	0.6	1.16	1.6	0.6	1.6	V
<b>EM74HCT14</b>								
$V_{T+}$	positive-going threshold voltage	see Fig. 7 and Fig. 8						
		$V_{CC} = 4.5\text{ V}$	1.2	1.45	1.9	1.2	1.9	V
		$V_{CC} = 5.5\text{ V}$	1.4	1.6	2.1	1.4	2.1	V
$V_{T-}$	negative-going threshold voltage	see Fig. 7 and Fig. 8						
		$V_{CC} = 4.5\text{ V}$	0.5	0.88	1.2	0.5	1.2	V
		$V_{CC} = 5.5\text{ V}$	0.6	1.05	1.4	0.6	1.4	V
$V_H$	hysteresis voltage	see Fig. 7 and Fig. 8						
		$V_{CC} = 4.5\text{ V}$	0.4	0.57		0.4		V
		$V_{CC} = 5.5\text{ V}$	0.4	0.55		0.4		V

### 11.1. Waveforms transfer characteristics

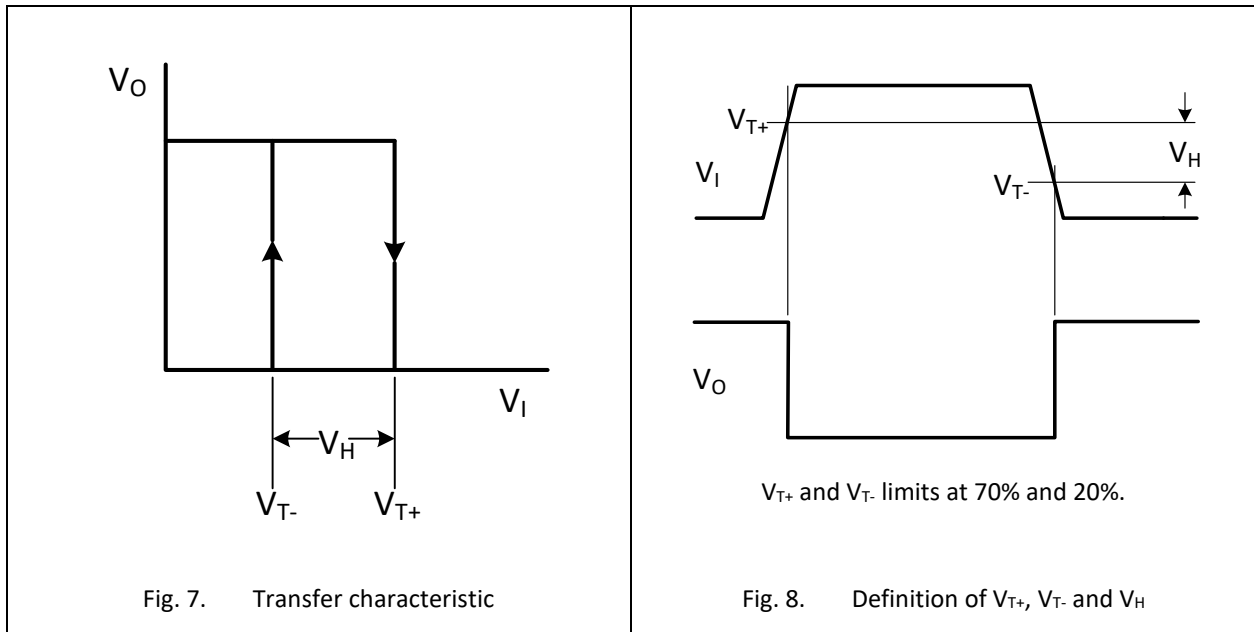

## 12. Package Outline

SOP-14L

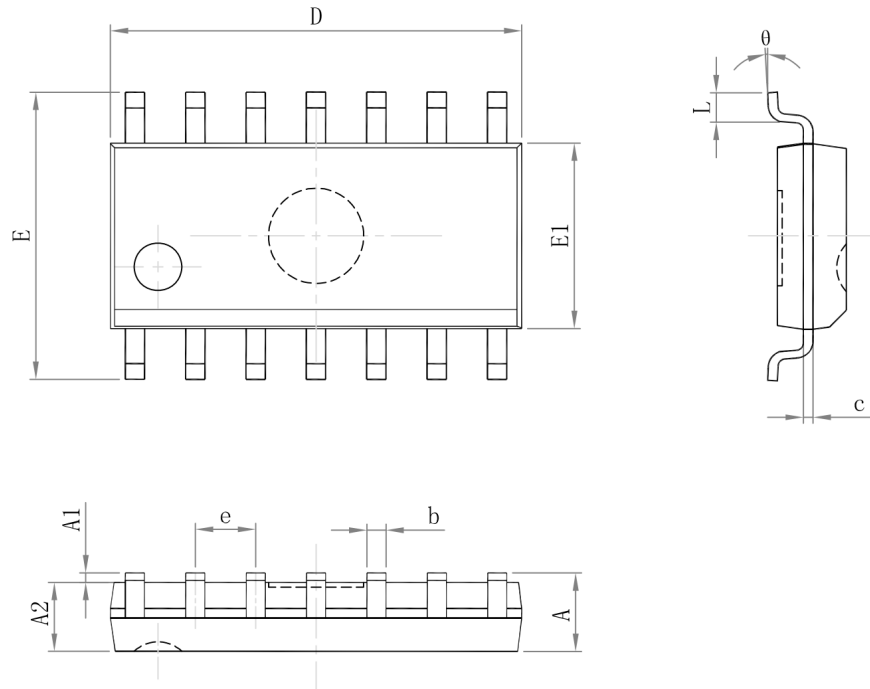

Symbol	Dimensions In Millimeters		Dimensions In Inches	
	Min	Max	Min	Max
A	--	1.750	--	0.069
A1	0.100	0.250	0.004	0.010
A2	1.250	--	0.049	--
b	0.310	0.510	0.012	0.020
c	0.100	0.250	0.004	0.010
D	8.450	8.850	0.333	0.348
E	5.800	6.200	0.228	0.244
E1	3.800	4.000	0.150	0.157
e	1.270(BSC)		0.050(BSC)	
L	0.400	1.270	0.016	0.050
$\theta$	0°	8°	0°	8°

# EM74HC14; EM74HCT14

Hex inverting Schmitt trigger

## TSSOP-14L

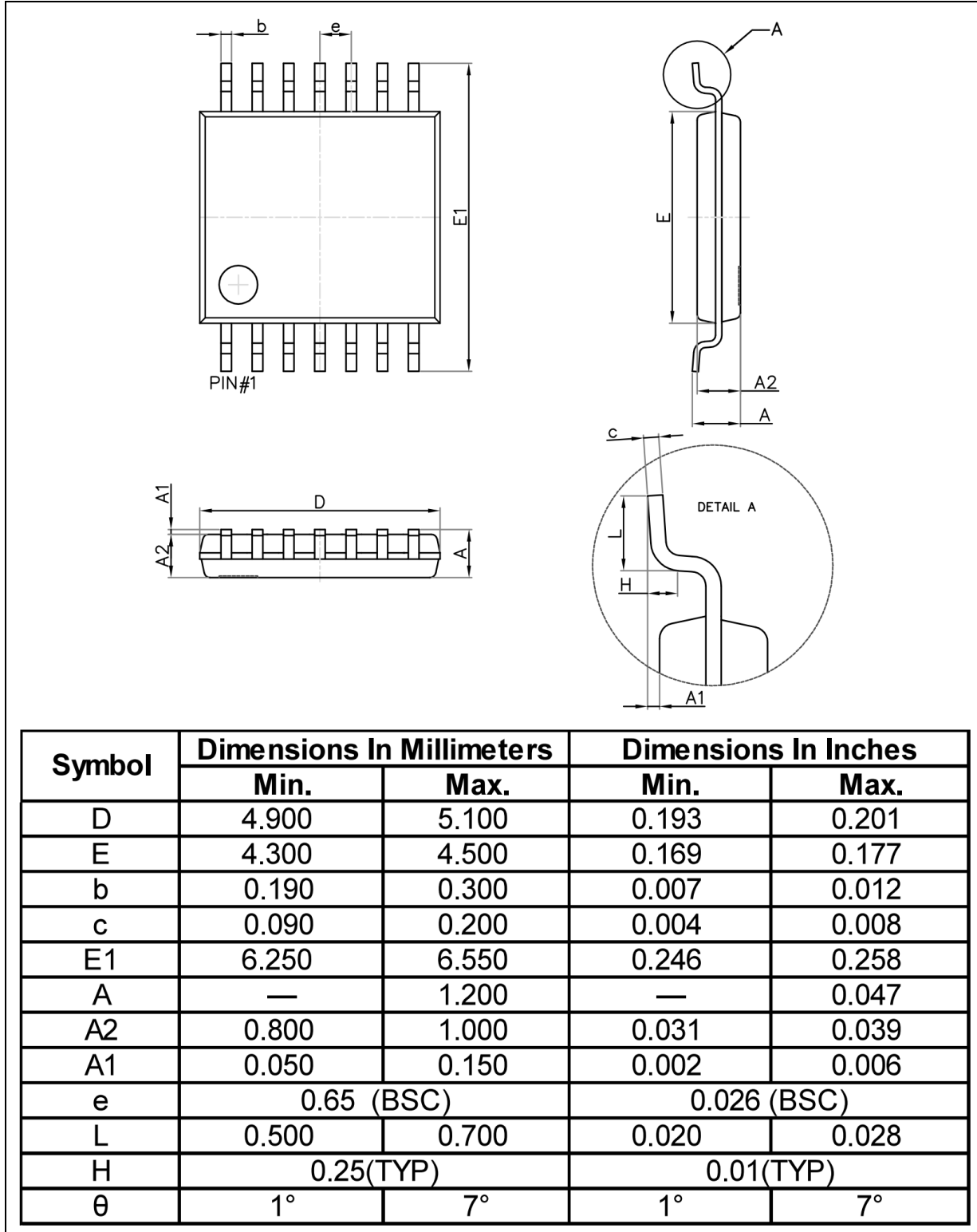

## 13. Abbreviations

**Table 11. Abbreviations**

Acronym	Description
CMOS	Complementary Metal-Oxide Semiconductor
DUT	Device Under Test
ESD	ElectroStatic Discharge
HBM	Human Body Model
CDM	Charged Device Model
TTL	Transistor-Transistor Logic

## 14. Revision History

**Table 12. Revision history**

Document ID	Release Date	Data sheet status	Change notice	Supersedes
EM74HC_HCT14 Rev. 1.3	Dec 12, 2025	Product datasheet		EM74HC_HCT14 Rev. 1.2
Modifications:	<ul style="list-style-type: none"> <li>Table 1: Added topside marking information.</li> </ul>			
EM74HC_HCT14 Rev. 1.2	Dec 12, 2025	Product datasheet		EM74HC_HCT14 Rev. 1.1
Modifications:	<ul style="list-style-type: none"> <li>Table 10: Added <math>V_{T+}</math>, <math>V_{T-}</math> and <math>V_H</math> specification when <math>V_{CC} = 3.3</math> V.</li> </ul>			
EM74HC_HCT14 Rev. 1.1	Aug 30, 2024	Product datasheet		EM74HC_HCT14 Rev. 1.0
Modifications:	<ul style="list-style-type: none"> <li>Table 7: <math>t_{pd}</math> and <math>C_{pd}</math> updated.</li> <li>Table 10: <math>V_{T+}</math>, <math>V_{T-}</math> and <math>V_H</math> updated.</li> </ul>			
EM74HC_HCT14 Rev. 1.0	Mar 28, 2024	Product datasheet		