

POWER MANAGEMENT

Description

The SC194A is a synchronous step-down converter with integrated power devices. The SC194A is designed for single-cell Li-Ion battery applications, but can also be used in fixed 3.3V or 5V applications. The switching frequency is nominally set to 1MHz, allowing the use of small inductors and capacitors. The 1.3A maximum current rating of the internal MOSFET switches allows a DC output current of 1A.

The SC194A has a flexible clocking methodology that allows it to be synchronized to an external oscillator or controlled by the internal oscillator. The device can operate in either forced PWM mode or in PSAVE mode. If PSAVE mode is enabled the part will automatically enter PFM at light loads to maintain maximum efficiency across the full load range.

For noise sensitive applications, PSAVE mode can be disabled by synchronizing to an external oscillator, or pulling the SYNC/PWM pin high. Shutdown turns off all the control circuitry to achieve a typical shutdown current of 0.1 μ A.

Features

- ◆ Up to 93% efficiency
- ◆ Output current - 1A
- ◆ Input range - 2.7V to 5.5V
- ◆ Quiescent current - 17 μ A
- ◆ Four selectable output voltages
- ◆ Dynamic voltage positioning capability
- ◆ Fixed 1MHz frequency or 750kHz to 1.25MHz synchronized operation
- ◆ PSAVE operation to maximize efficiency at light loads
- ◆ Minimal external components
- ◆ Fast transient response
- ◆ 100% duty cycle in dropout
- ◆ Soft-start
- ◆ Over-temperature and short-circuit protection
- ◆ Space-saving lead-free package - MLP-10, 3 x 3mm

Applications

- ◆ Cell phones
- ◆ Wireless communication chipset power
- ◆ Personal media player
- ◆ Notebook and sub-notebook computers
- ◆ PDAs and mobile communicators
- ◆ WLAN peripherals

Typical Application Circuit

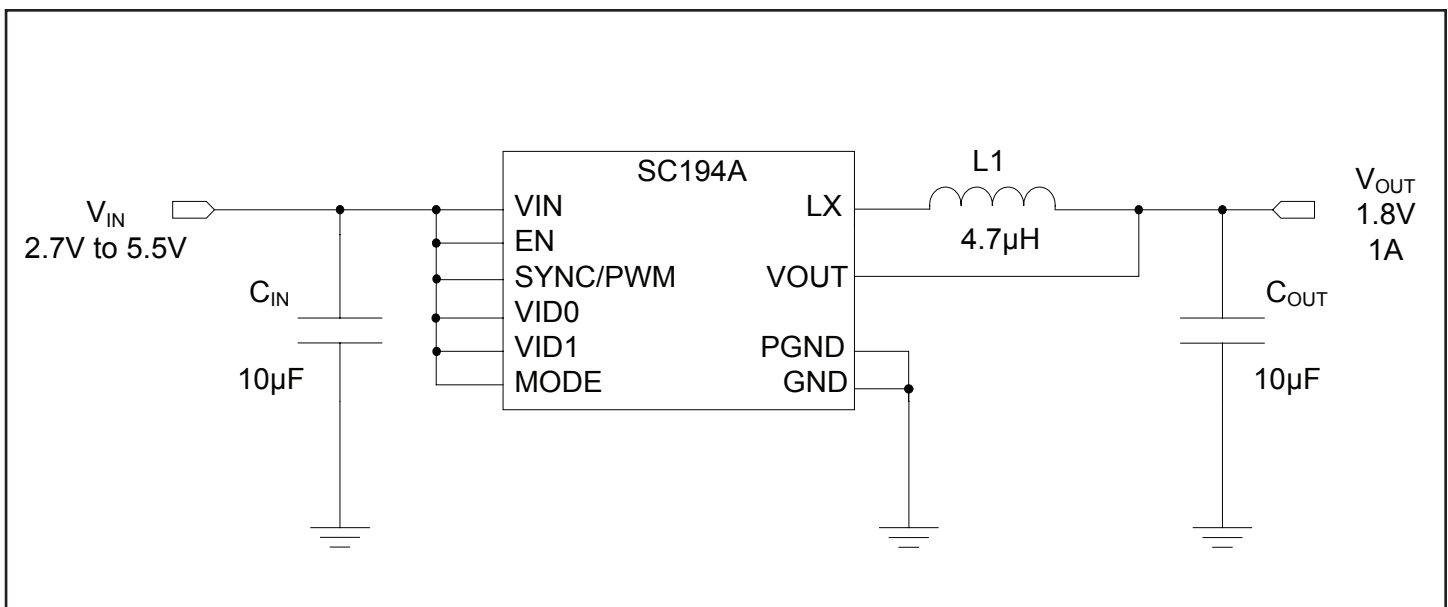

POWER MANAGEMENT
Absolute Maximum Ratings

Exceeding the specifications below may result in permanent damage to the device or device malfunction. Operation outside of the parameters specified in the Electrical Characteristics section is not recommended.

Parameter	Symbol	Maximum	Units
Input Supply Voltage	V_{IN}	-0.3 to 7	V
Logic Inputs (SYNC/PWM, EN, MODE, VID0, VID1)	V_N	-0.3 to $V_{IN}+0.3$, 7V Max	V
Output Voltage	V_{OUT}	-0.3 to $V_{IN}+0.3$, 7V Max	V
LX Voltage	V_{LX}	-1 to $V_{IN} +1$, 7V Max	V
Thermal Impedance Junction to Ambient ⁽¹⁾	θ_{JA}	40	°C/W
VOU Short-Circuit to GND	t_{SC}	Continuous	s
Operating Ambient Temperature Range	T_A	-40 to +85	°C
Storage Temperature	T_S	-60 to +160	°C
Junction Temperature	T_{JC}	-40 to +150	°C
Peak IR Reflow Temperature	T_{LEAD}	260	°C
ESD Protection Level ⁽²⁾	V_{ESD}	2	kV

Note:

- 1) Calculated from package in still air, mounted to 3" x 4.5", 4 layer FR4 PCB with thermal vias under the exposed pad per JESD51 standards.
- 2) Tested according to JEDEC standard JESD22-A114-B.

Electrical Characteristics

Unless otherwise noted: $V_{IN} = 3.6V$, $EN = V_{IN}$, $SYNC/PWM = V_{IN}$, $MODE = V_{IN}$, $T_A = -40$ to $85^\circ C$. Typical values are at $T_A = 25^\circ C$.

Parameter	Symbol	Conditions	Min	Typ	Max	Units
Input Voltage Range	V_{IN}		2.7		5.5	V
VOU Accuracy	V_{OUT}	$I_{OUT} = 0.5A$, $T_A = 25^\circ C$			±1	%
VOU Temperature Accuracy	$V_{OUT(T)}$	$I_{OUT} = 0.5A$, $T_A = -40$ to $85^\circ C$		±0.3	±0.7	%
Line Regulation	$V_{OUT LINE}$	$V_{IN} = 2.7V$ to $5.5V$, $V_{OUT} = 1.8V$, $I_{OUT} = 0.5A$, $T_A = -40$ to $85^\circ C$		±0.4	±0.65	%
Load Regulation (PWM)	$V_{OUT LOAD}$	$I_{OUT} = 0A$ to $1A$, $T_A = -40$ to $85^\circ C$		±0.3	±0.65	%
PSAVE Regulation	$V_{OUT PSAVE}$	$SYNC/PWM = GND$, $C_{OUT} = 22 \mu F$		+1.3 -0.3	+1.6 -0.6	%
P-Channel On Resistance	R_{DSP}	$I_{LX} = 100mA$		0.275		Ω
N-Channel On Resistance	R_{DSN}	$I_{LX} = 100mA$		0.165		Ω
Start-Up Time	T_{START}				5	ms
P-Channel Current Limit	$I_{LIM(P)}$		1.33	1.9	2.47	A

POWER MANAGEMENT
Electrical Characteristics (Cont.)

Parameter	Symbol	Conditions	Min	Typ	Max	Units
Quiescent Current	I_Q	SYNC/PWM = GND, $I_{OUT} = 0A$, $V_{OUT} = 1.04 \times V_{OUT(Programmed)}$		17	28	μA
Shutdown Current	I_{SD}	EN = GND, LX = OPEN		0.1	1	μA
LX Leakage Current PMOS	I_{LXP}	LX = GND, EN = GND		0.1	2	μA
LX Leakage Current NMOS	I_{LXN}	LX = 3.6V, EN = GND	-2	0.1		μA
Oscillator Frequency	f_{OSC}		0.85	1.0	1.15	MHz
SYNC Frequency (upper)	f_{SYNCU}		1.25			MHz
SYNC Frequency (lower)	f_{SYNCL}				750	kHz
UVLO Threshold (upper)	V_{UVL}		2.38	2.52	2.65	V
UVLO Hysteresis	V_{UVLHYS}			50		mV
Thermal Shutdown	T_{SD}			145		$^{\circ}C$
Thermal Shutdown Hysteresis	T_{SD-HYS}			10		$^{\circ}C$
Logic Input High	V_{IH}	EN, SYNC/PWM, VID0, VID1, MODE	1.6			V
Logic Input Low	V_{IL}	EN, SYNC/PWM, VID0, VID1, MODE			0.6	V
Logic Input Current High	I_{IH}	EN, SYNC/PWM, VID0, VID1, MODE	-2	0.1	2	μA
Logic Input Current Low	I_{IL}	EN, SYNC/PWM, VID0, VID1, MODE	-2	0.1	2	μA

POWER MANAGEMENT

Pin Configuration

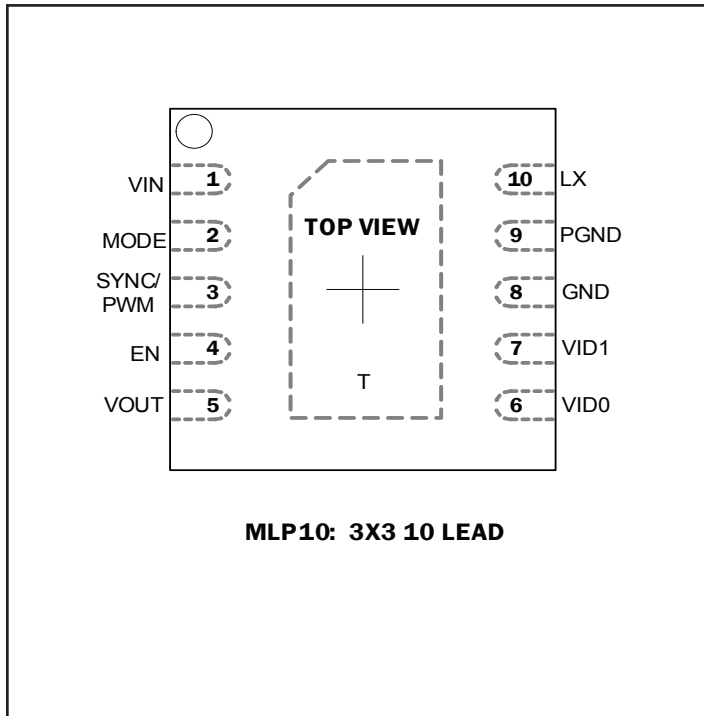

Ordering Information

DEVICE	PACKAGE
SC194AMLTRT ⁽¹⁾⁽²⁾	MLP 3x3-10
SC194AEVB	Evaluation Board

Notes:

- 1) Lead-free packaging only. This product is fully WEEE and RoHS compliant.
- 2) Available in tape and reel only. A reel contains 3000 devices.

Programmable Output Voltage

VID1	VID0	SC194A V _{OUT}
0	0	1.0V
0	1	1.2V
1	0	1.5V
1	1	1.8V

Marking Information

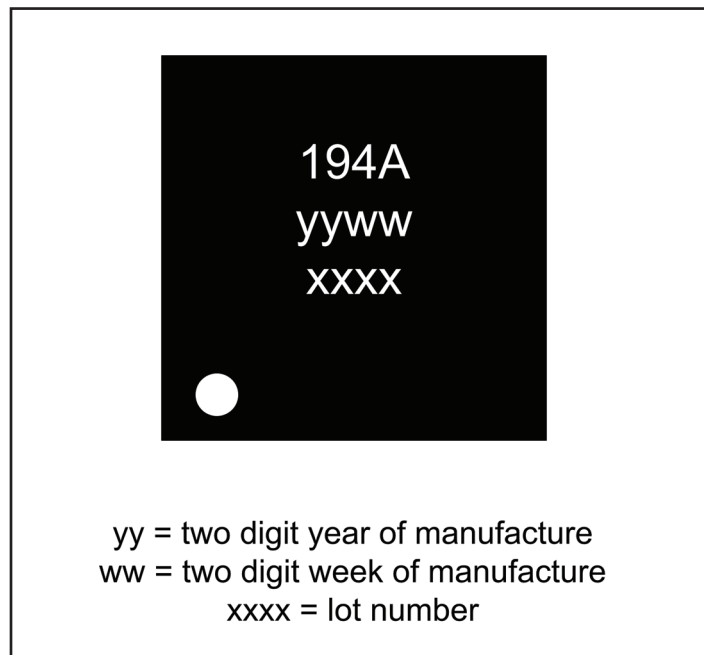

POWER MANAGEMENT

Block Diagram

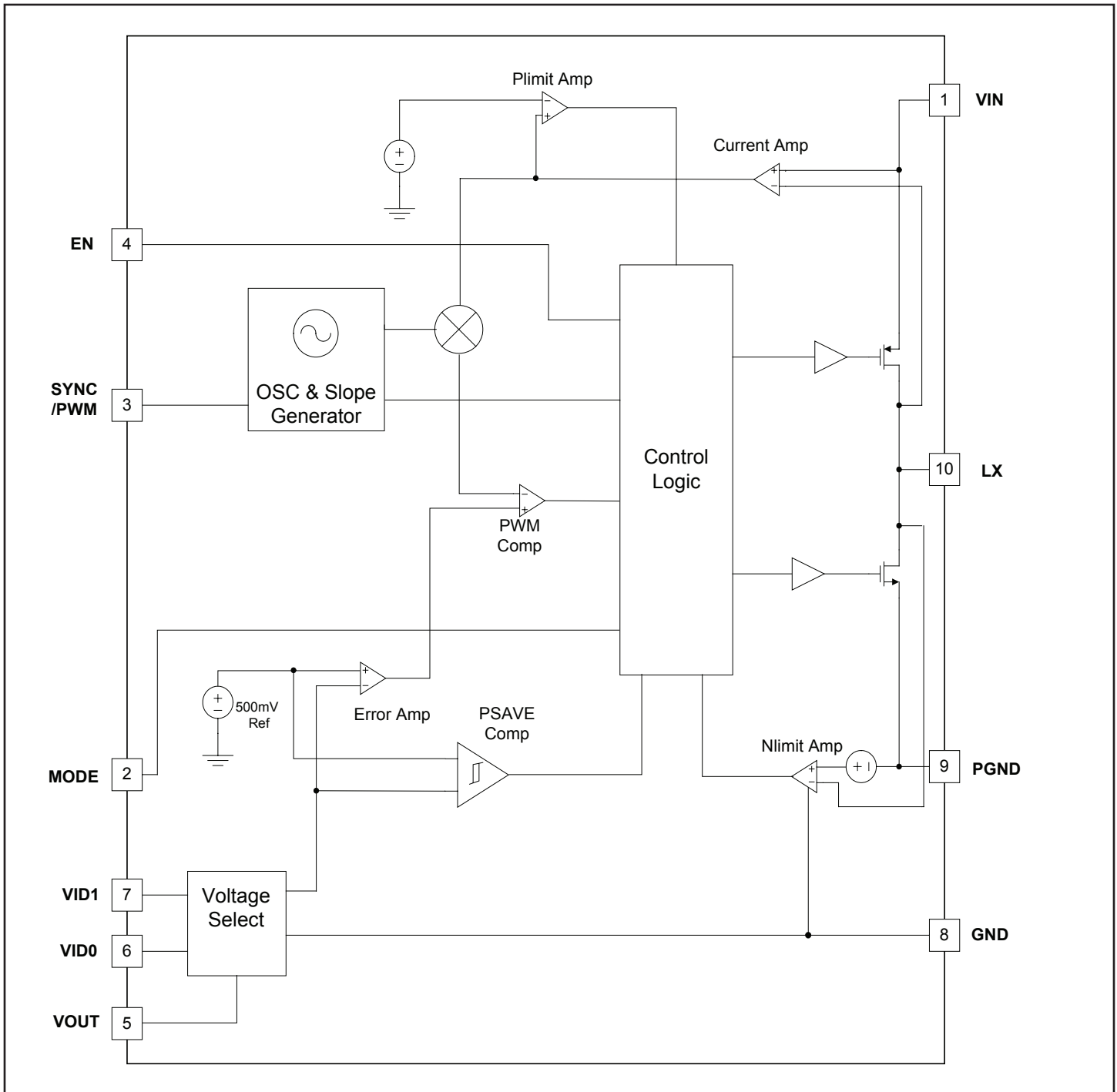

POWER MANAGEMENT
Pin Descriptions

Pin #	Pin Name	Pin Function
1	VIN	Input power supply voltage
2	MODE	MODE select pin - MODE = V_{IN} to select 100% duty cycle function, MODE = GND to disable
3	SYNC/PWM	Oscillator synchronization input - Tie to V_{IN} for forced PWM mode or GND to allow the part to enter PSAVE mode at light loads. Apply an external clock signal for frequency synchronization.
4	EN	Enable digital input - a high input enables the SC194A, a low disables and reduces quiescent current to less than 1 μ A. In shutdown, LX becomes high impedance.
5	VOUT	Regulated output voltage and feedback for SC194A
6	VID0	Logic level bit 0 used in conjunction with VID1 to set the output voltage. Connect high or low as required to select the desired output voltage. If not connected, the output voltage will be indeterminate.
7	VID1	Logic level bit 1 used in conjunction with VID0 to set the output voltage. Connect high or low as required to select the desired output voltage. If not connected, the output voltage will be indeterminate.
8	GND	Ground
9	PGND	Power Ground
10	LX	Inductor connection to the switching FETs
T	THERMAL PAD	Pad for heatsinking purposes - not connected internally. Connects to ground plane using multiple vias.

POWER MANAGEMENT

Applications Information

SC194A Detailed Description

The SC194A is a synchronous step-down Pulse Width Modulated (PWM), DC-DC converter utilizing a 1MHz fixed-frequency current mode architecture. The device is designed to operate in a fixed-frequency PWM mode across the full load range and can enter Power Save Mode (PSAVE) utilizing Pulse Frequency Modulation (PFM) at light loads to maximize efficiency.

Operation

During normal operation the PMOS MOSFET is activated on each rising edge of the internal oscillator. Current feedback for the switching regulator uses the PMOS current path, and it is amplified and summed with the internal slope compensation network. The voltage feedback loop uses an internal feedback divider. The on-time is determined by comparing the summed current feedback and the output of the error amplifier. The period is set by the onboard oscillator or by an external clock attached to the SYNC/PWM pin.

The SC194A has an internal synchronous NMOS rectifier and does not require a Schottky diode on the LX pin.

Programmable Output Voltage

The SC194A has four pre-determined output voltage values which can be individually selected by the correct programming of the VIDO and VID1 pins (see Programmable Output Voltage table on Page 4). This eliminates the need for external programming resistors saving PCB area and inventory. The VID pins can be statically tied to GND or VIN for fixed output configurations or they may be driven by a microprocessor enabling the possibility of dynamic voltage adjustment for host equipment "sleep" states.

Continuous Conduction & Oscillator Synchronization

The SC194A is designed to operate in continuous conduction, fixed-frequency mode. When the SYNC/PWM pin is tied high the part runs in PWM mode using the internal oscillator. The part can be synchronized to an external clock by driving a clock signal into the SYNC/PWM pin. The part synchronizes to the rising edge of the clock.

Protection Features

The SC194A provides the following protection features:

- Thermal shutdown
- Current limit

- Over-voltage protection
- Soft-start

Thermal Shutdown

The device has a thermal shutdown feature to protect the SC194A if the junction temperature exceeds 145°C. In thermal shutdown the on-chip power devices are disabled, tri-stating the LX output. Switching will resume when the temperature drops by 10°C. During this time if the output voltage decreases by more than 60% of its programmed value, a soft-start will be invoked.

Current Limit

The PMOS and NMOS power devices of the buck switcher stage are protected by current limit functions. In the case of a short to ground on the output, the part enters frequency foldback mode, that causes the switching frequency to divide by a factor determined by the output voltage. This prevents the inductor current from "stair-casing".

Over-Voltage Protection

Over-voltage protection is provided on the SC194A. In the event of an over-voltage on the output in switcher mode, the PWM drive is disabled, tri-stating the LX output. The part will not resume switching until the output voltage has fallen below 2% of the regulation voltage.

Soft-Start

The soft-start mode is enabled after every shutdown cycle to limit in-rush current. In conjunction with the frequency foldback, this controls the maximum current during start-up. The PMOS current limit is stepped up through seven soft-start levels to the full value by a timer driven from the internal oscillator. During soft-start, the switching frequency is stepped by 1/8, 1/4, and 1/2 of the internal oscillator frequency up to the full value, under control of three output voltage thresholds. As soon as the output voltage is within 2% of the regulation voltage, soft-start mode is disabled.

Power Save Mode Operation

The PSAVE mode may be selected by tying the SYNC/PWM pin to GND. Selecting PSAVE mode will enable the SC194A to automatically activate/deactivate operation at light loads maximizing efficiency across the full load range. The SC194A automatically detects the load current at which it should enter PSAVE mode. The SC194A is optimized to track maximum efficiency with respect to V_{IN} .

POWER MANAGEMENT

Applications Information (Cont.)

In PSAVE mode V_{OUT} is driven from a lower level to an upper level by a switching burst. Once the upper level has been reached the switching is stopped and the quiescent current is reduced. V_{OUT} falls from the upper to lower levels in this low current state as the load current discharges the output capacitor. The burst-to-off period in PSAVE will decrease as the load current reduces.

The PSAVE switching burst frequency is controlled so that the inductor current ripple is similar to that in PWM mode. The minimum switching frequency during this period is limited to 650kHz.

The SC194A automatically detects when to exit PSAVE mode by monitoring V_{OUT} . For the SC194A to exit PSAVE mode, the load must be increased, causing V_{OUT} to decrease until the power save exit threshold is reached. PSAVE levels are set high to minimize the undershoot when exiting PSAVE. The lower PSAVE comparator level is set +0.7% above V_{OUT} , and the upper comparator level at +1.5% above V_{OUT} with the exit threshold at -2% below V_{OUT} .

If PSAVE operation is required then a 22µF output capacitor must be used.

100% Duty Cycle Operation

The 100% duty cycle mode may be selected by connecting the MODE pin high. This will allow the SC194A to maintain output regulation under low input voltage/high output voltage conditions.

In 100% duty cycle operation, as the input supply drops toward the output voltage, the PMOS on-time increases linearly above the maximum value in fixed-frequency operation until the PMOS is active continuously. Once the PMOS is switched on continuously, the output voltage tracks the input voltage minus the voltage drop across the PMOS power device and inductor according to the following relationship:

$$V_{OUT} = V_{IN} - I_{OUT} \times (R_{DSP} + R_{IND})$$

where,

- V_{OUT} = Output voltage
- V_{IN} = Input voltage
- I_{OUT} = Output current
- R_{DSP} = PMOS switch ON resistance
- R_{IND} = Series resistance of the inductor

The 100% duty cycle can only operate for a programmed output voltage of 1.8V.

With an output voltage of 1.8V, 100% duty cycle mode will only be required to maintain regulation if V_{IN} falls below a minimum value shown in the graph below.

Power Save Operation

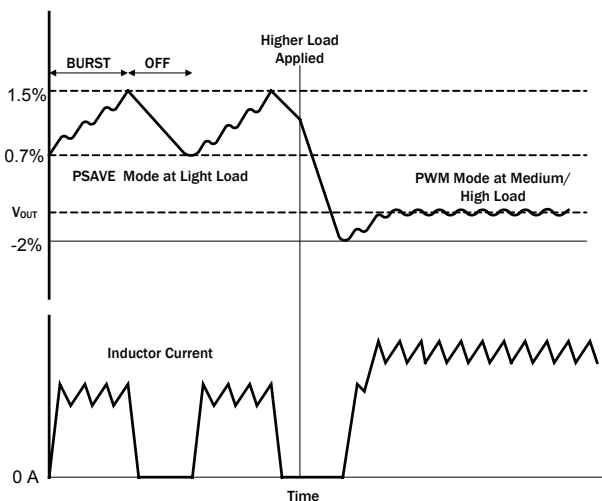

Minimum V_{IN} for Fixed Frequency Operation Vs. R_{IND}

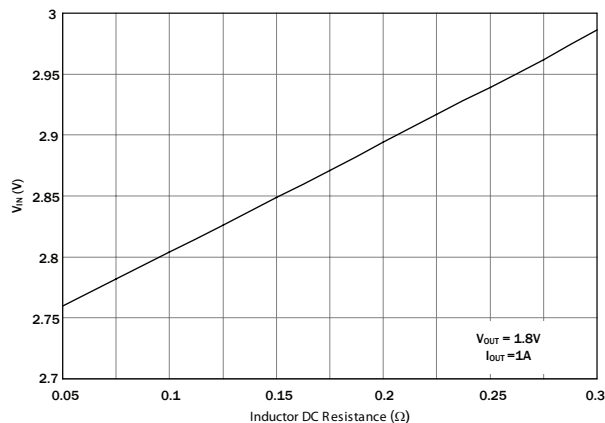

POWER MANAGEMENT
Applications Information (Cont.)

The SC194A is designed for use with a 4.7μH inductor. The magnitude of the inductor current ripple is dependent on the inductor value and can be determined by the following equation:

$$\Delta I_L = \frac{V_{OUT}}{L \times f_{OSC}} \left(1 - \frac{V_{OUT}}{V_{IN}} \right)$$

This equation demonstrates the relationship between input voltage, output voltage, and inductor ripple current.

The inductor should have a low DCR to minimize the conduction losses and maximize efficiency. As a minimum requirement, the DC current rating of the inductor should be equal to the maximum load current plus half of the inductor current ripple as shown by the following equation:

$$I_{L(PK)} = I_{OUT(MAX)} + \frac{\Delta I_L}{2}$$

Final inductor selection will depend on various design considerations such as efficiency, EMI, size and cost. Table 1 lists the manufacturers of practical inductor options.

C_{IN} Selection

The source input current to a buck converter is non-continuous. To prevent large input voltage ripple a low ESR ceramic capacitor is required. A minimum value of 10μF should be used for sufficient input voltage filtering and a 22μF should be used for improved input voltage filtering.

C_{OUT} Selection

The internal compensation is designed to work with a certain output filter corner frequency defined by the equation:

$$f_c = \frac{1}{2\pi\sqrt{L \times C_{OUT}}}$$

This single pole filter is designed to operate with a minimum output capacitor value of 10μF. Larger output capacitor values will improve transient performance. If PSAVE operation is required the minimum capacitor value is 22μF.

Output voltage ripple is a combination of the voltage ripple from the inductor current charging and discharging the output capacitor and the voltage created from the inductor current ripple through the output capacitor ESR. Selecting an output capacitor with a low ESR will reduce the output voltage ripple component, as can be seen in the following equation:

$$\Delta V_{OUT(ESR)} = \Delta I_{L(ripple)} \times ESR_{C_{OUT}}$$

Capacitors with X7R or X5R ceramic dielectric are strongly recommended for their low ESR and superior temperature and voltage characteristics. Y5V capacitors should not be used as their temperature coefficients make them unsuitable for this application. Table 2 lists the manufacturers of recommended capacitor options.

Table 1: Recommended Inductors

Manufacturer/Part #	Value μH	DCR Ω	Saturation Current A	Tolerance ±%	Dimensions (LxWxH) mm
BI Technologies HM66304R7	4.7	0.072	1.32	20	4.7 × 4.7 × 3.0
Coilcraft D01608C-472ML	4.7	0.09	1.5	20	6.6 × 4.5 × 3.0
TDK VLCF4018T-4R7N1R0-2	4.7	0.101	1.07	30	4.3 × 4.0 × 1.8

Table 2: Recommended Capacitors

Manufacturer/Part #	Value μF	Rated Voltage VDC	Temperature Characteristic	Case Size
Murata GRM21BR60J226ME39L	22	6.3	X5R	0805
Murata GRM188R60J106 MKE19	10	6.3	X5R	0603
TDK C2012X5R0J106K	10	6.3	X5R	0603

Note: Where PSAVE operation is required 22μF must be used for C_{OUT}

POWER MANAGEMENT

Applications Information (Cont.)

PCB Layout Considerations

Poor layout can degrade the performance of the DC-DC converter and can contribute to EMI problems, ground bounce and resistive voltage losses. Poor regulation and instability can result.

A few simple design rules can be implemented to ensure good layout:

1. Place the inductor and filter capacitors as close to the device as possible and use short wide traces between the power components.
2. Route the output voltage feedback path away from the inductor and LX node to minimize noise and magnetic interference.
3. Maximize ground metal on the component side to improve the return connection and thermal dissipation. Separation between the LX node and GND should be maintained to avoid coupling of switching noise to the ground plane.
4. Use a ground plane with several vias connecting to the component side ground to further reduce noise interference on sensitive circuit nodes.

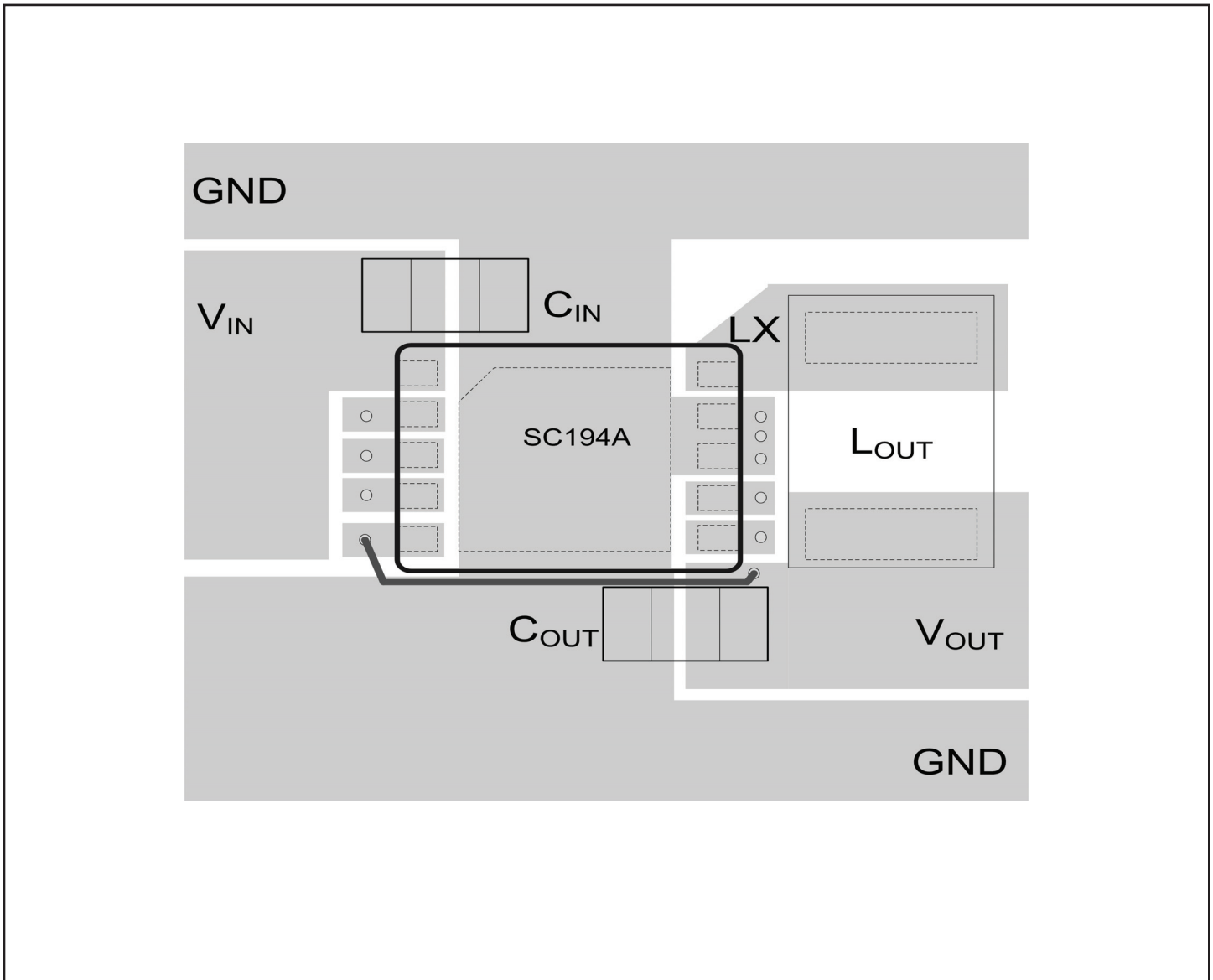

Efficiency vs. Load Current $V_{OUT} = 1.8V$

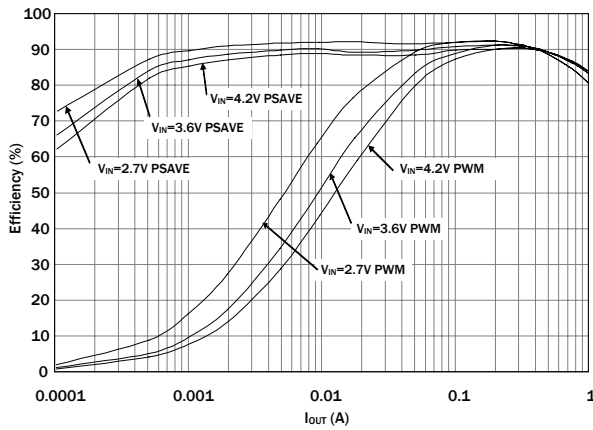

Efficiency vs. Load Current $V_{OUT} = 1.5V$

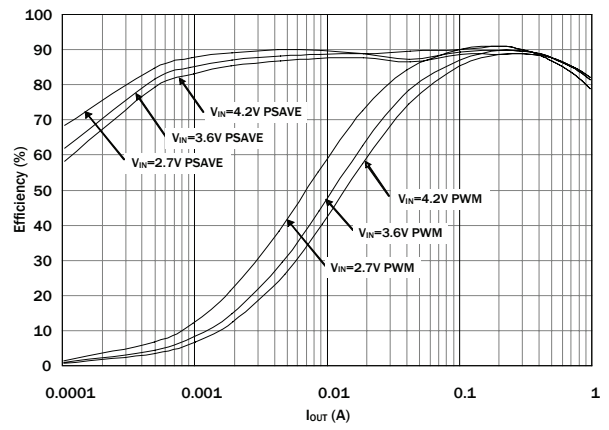

Efficiency vs. Load Current $V_{OUT} = 1.2V$

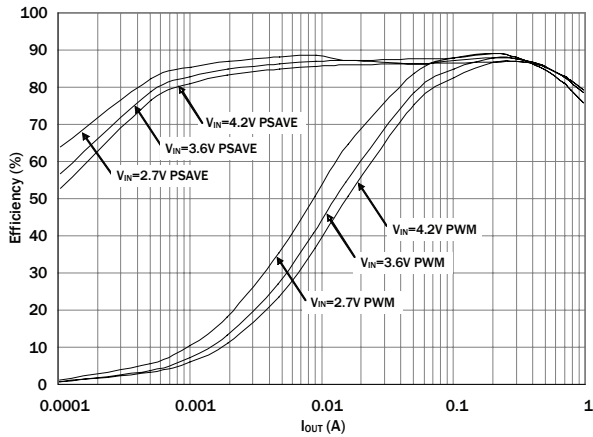

Efficiency vs. Load Current $V_{OUT} = 1.0V$

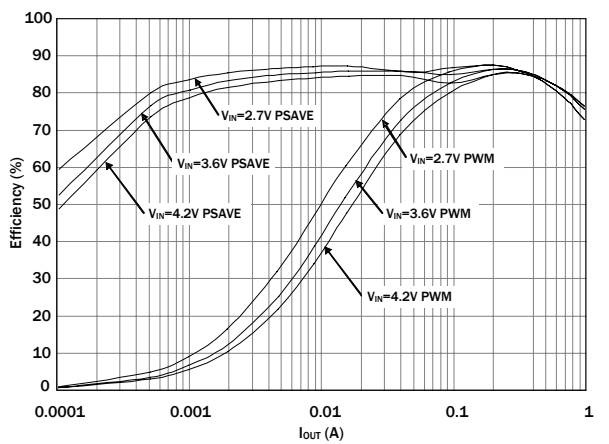

Efficiency vs. Input Voltage

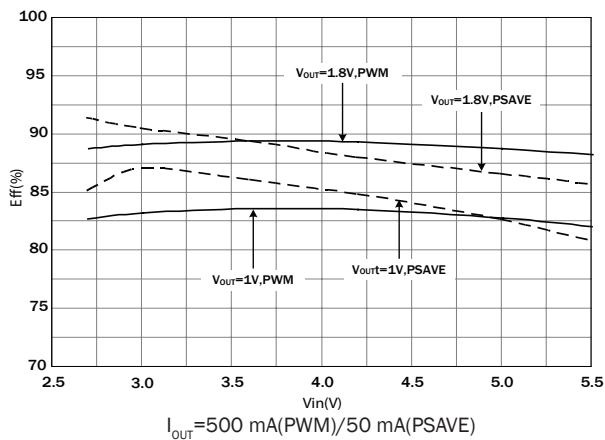

PWM to PSAVE Hysteresis

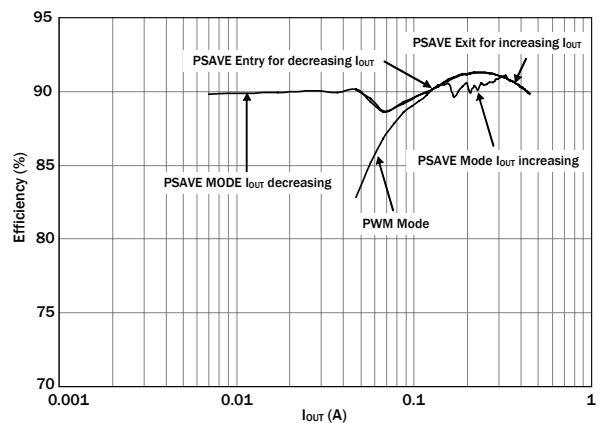

POWER MANAGEMENT

Typical Characteristics (Cont.)

V_{OUT} vs. V_{IN}

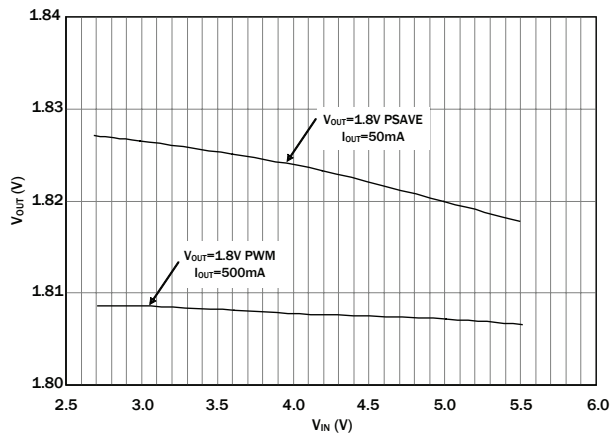

V_{OUT} vs. I_{OUT} , $V_{OUT}=1.8V$, PWM

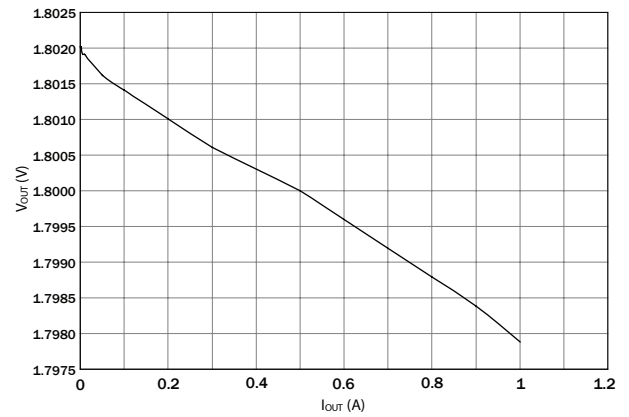

V_{OUT} vs. Temperature
 $V_{OUT}=1.8V$, PWM

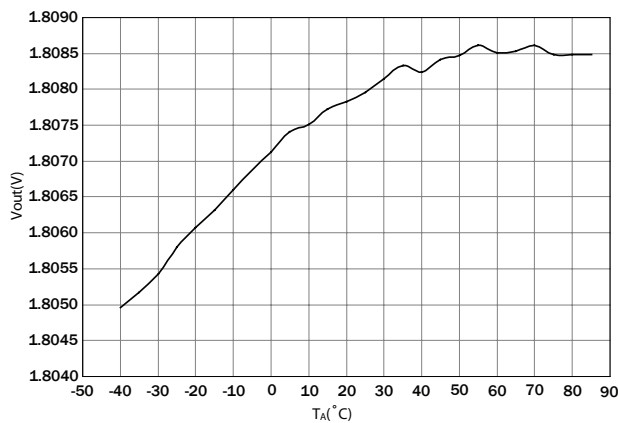

Quiescent Current vs. Input Voltage

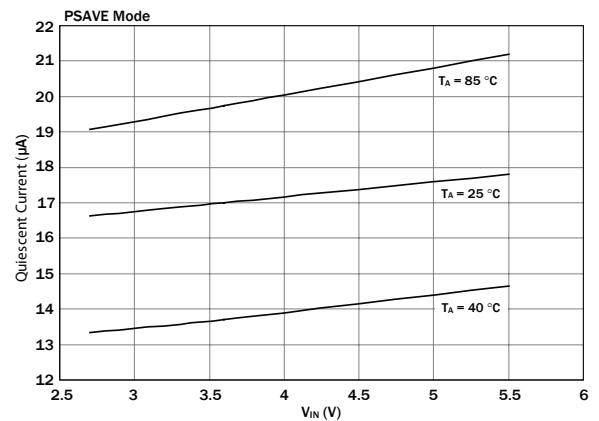

Quiescent Current vs. Input Voltage

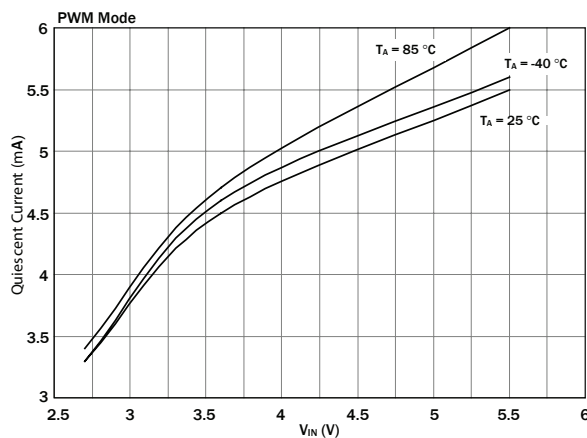

P-Channel $R_{DS(ON)}$ vs. Input Voltage

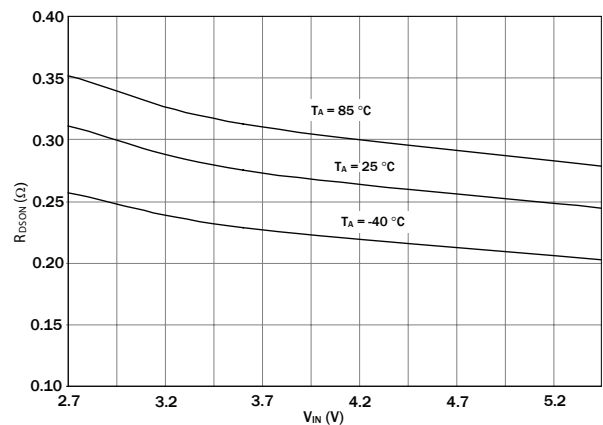

POWER MANAGEMENT

Typical Characteristics (Cont.)

N-Channel $R_{DS(ON)}$ vs. Input Voltage

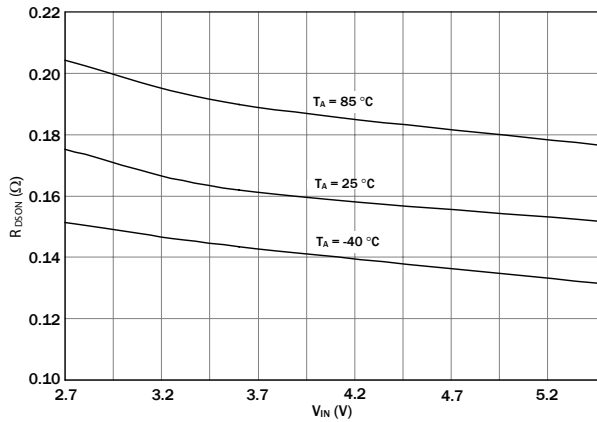

Switching Frequency vs. Temperature

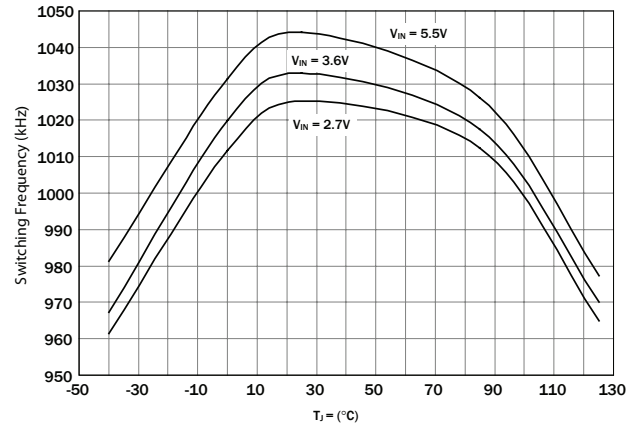

100% Duty Cycle Mode

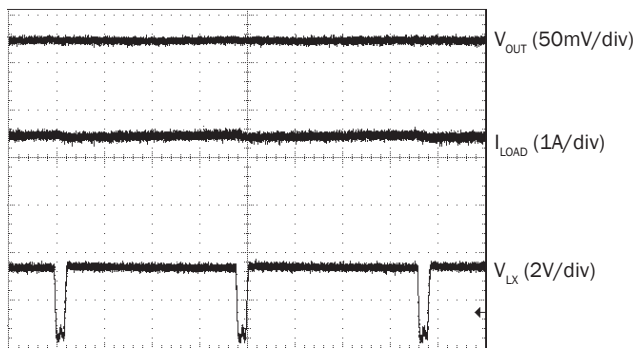

Time (400ns/div)
Condition $V_{IN}=2.6V$, $V_{OUT}=1.8V$, $I_{OUT}=1.4A$,
SYNC/PWM=1.15MHz ext clock

PSAVE Operation

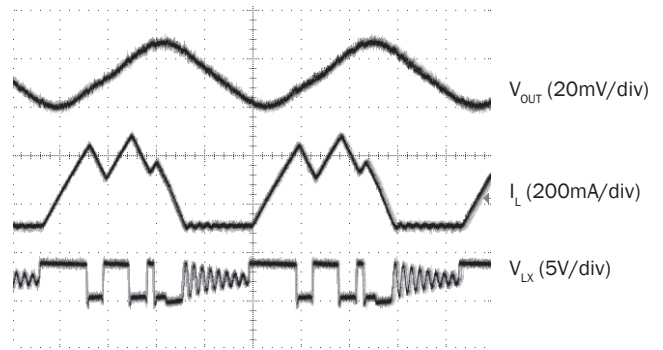

Time (1us/div)
Condition $V_{IN}=3.6V$, $V_{OUT}=1.8V$, $I_{OUT}=150mA$,
SYNC/PWM=GND

PWM Operation

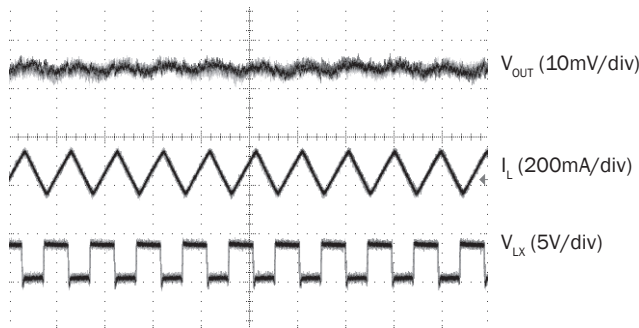

Time (1us/div)
Condition $V_{IN}=3.6V$, $V_{OUT}=1.8V$, $I_{OUT}=150mA$,
SYNC/PWM= V_{IN}

PSAVE Start up

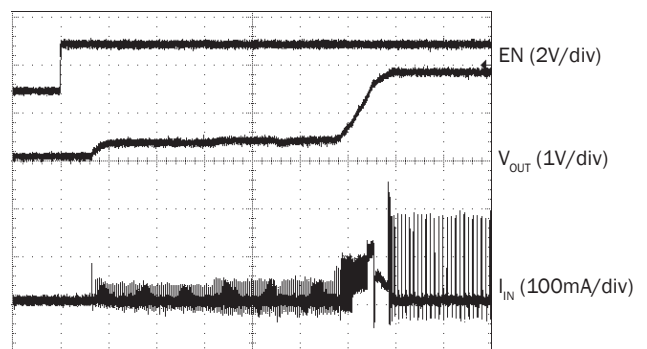

Time (200us/div)
Condition $V_{IN}=3.6V$, $V_{OUT}=1.8V$, $I_{OUT}=10mA$,
SYNC/PWM=GND

POWER MANAGEMENT

Typical Characteristics (Cont.)

PWM Start-up

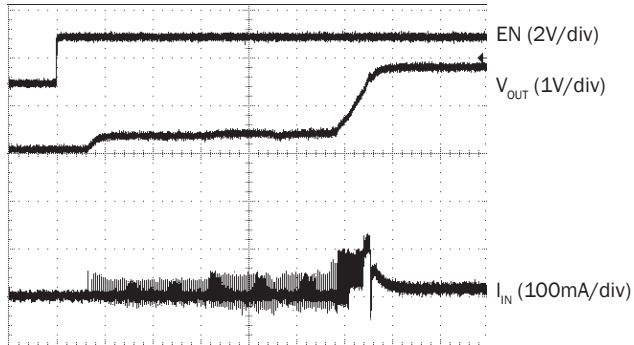

Time (200us/div)
 Condition $V_{IN}=3.6V$, $V_{OUT}=1.8V$, $I_{OUT}=10mA$,
 SYNC/PWM= V_{IN}

Load Transient Response PWM

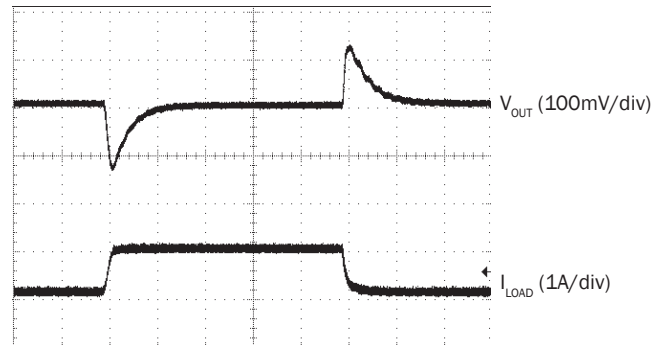

Time (100us/div)
 Condition $V_{IN}=3.6V$, $V_{OUT}=1.8V$, $I_{OUT}=1A$ to 100mA,
 SYNC/PWM= V_{IN}

Load Transient Response PSAVE

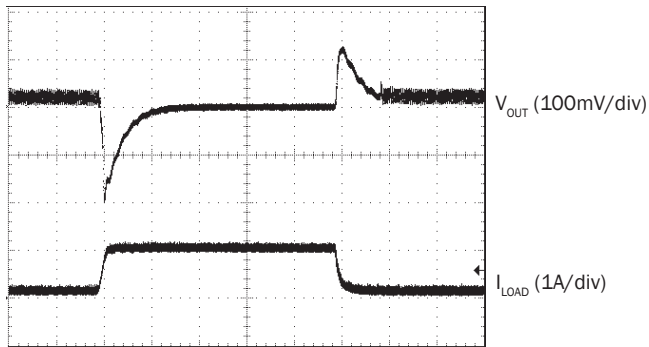

Time (100us/div)
 Condition $V_{IN}=3.6V$, $V_{OUT}=1.8V$, $I_{OUT}=1A$ to 100 mA,
 SYNC/PWM=GND

VID Code Change

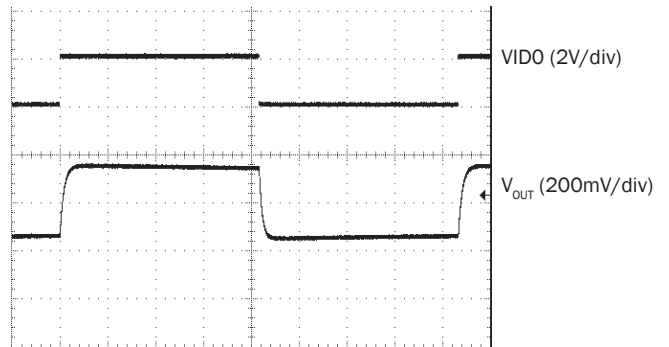

Time (400us/div)
 Condition $V_{IN}=3.6V$, $V_{OUT}=1.8V$ to 1.5V, $I_{OUT}=1A$,
 SYNC/PWM= V_{IN}

POWER MANAGEMENT

Applications Circuits

$V_{OUT} = 1.8V$ with PSAVE and 100% Duty Cycle

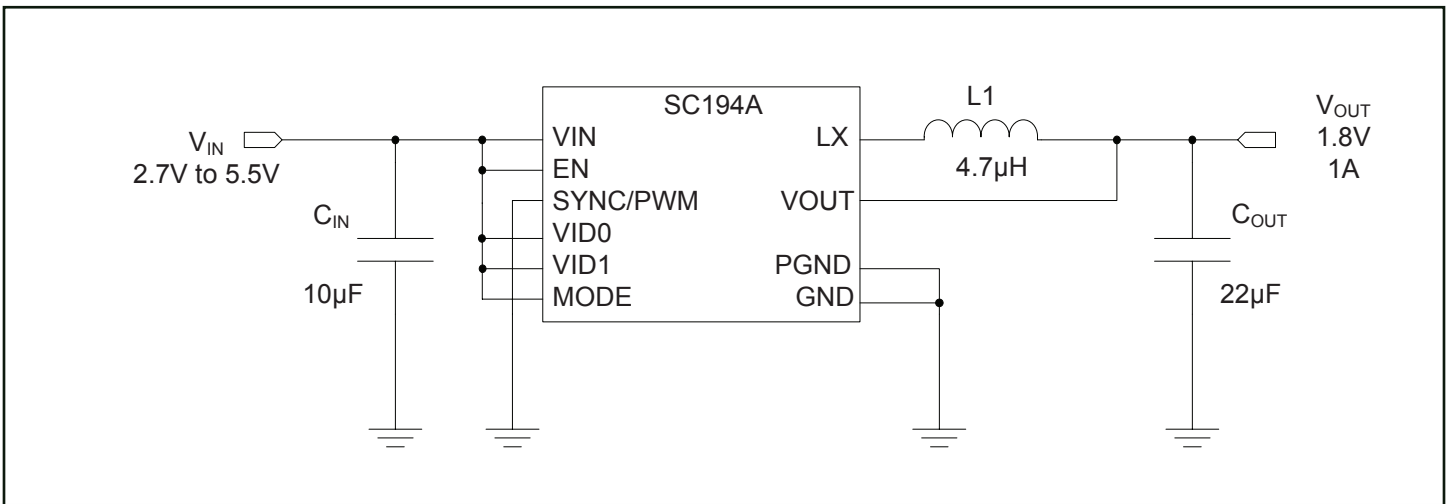

Mobile Voltage Positioning for Reduced System Dissipation in "Sleep" Modes

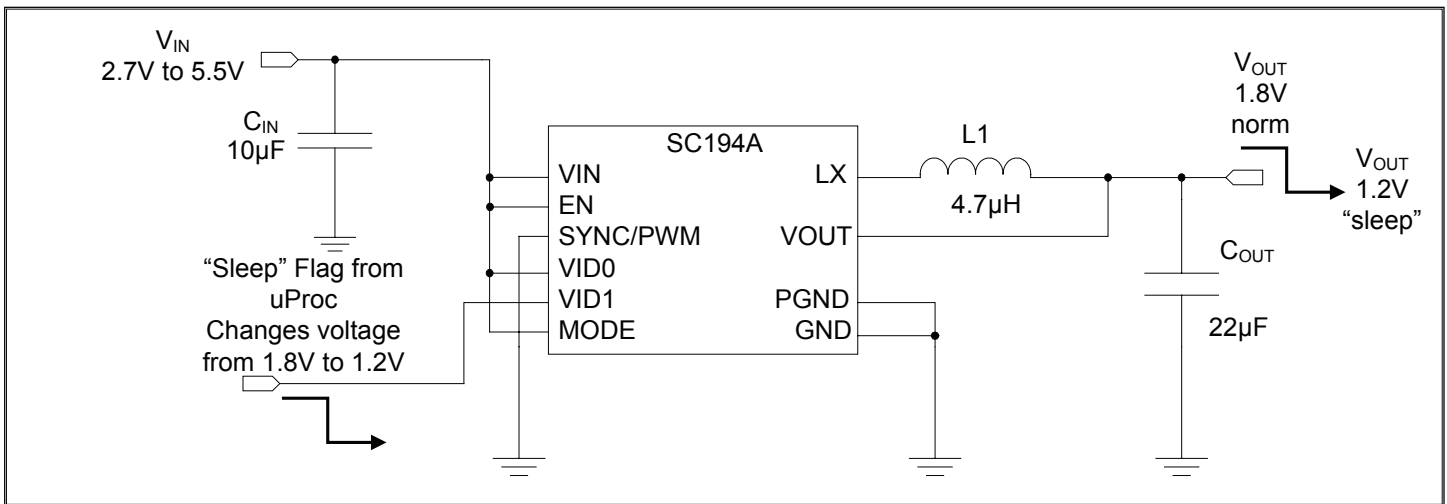

$V_{OUT} = 1.0V$ with Forced PWM and no 100% Duty Cycle

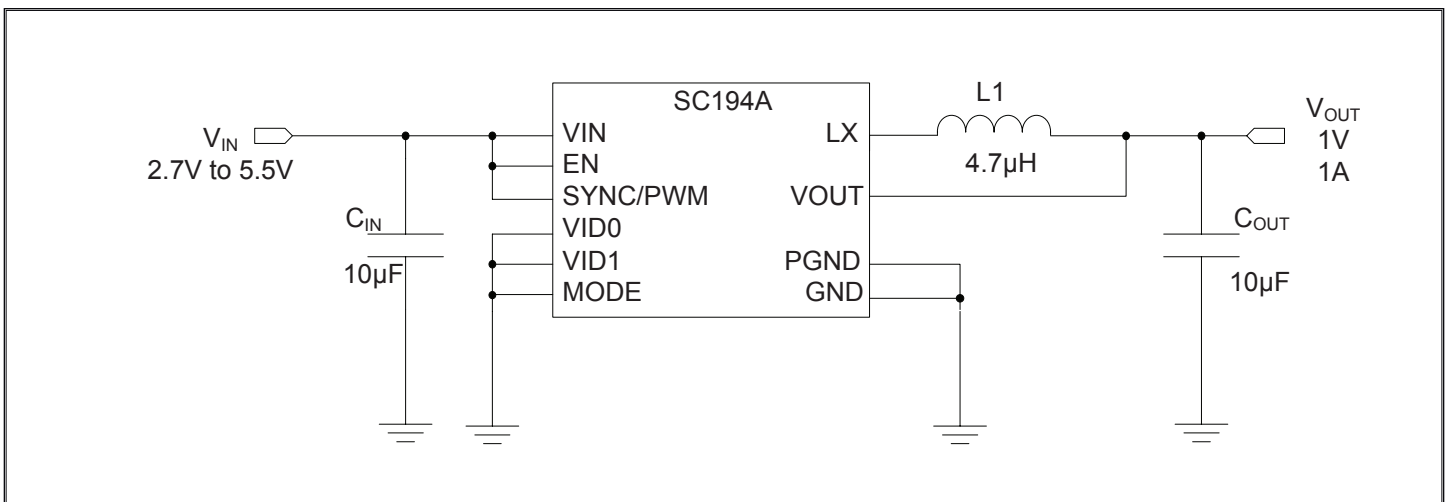

POWER MANAGEMENT

Outline Drawing - MLP-10

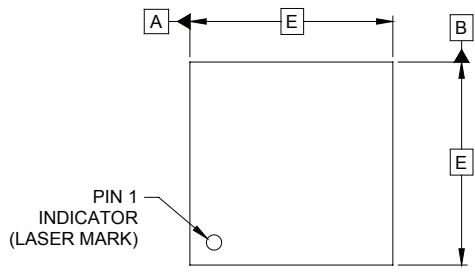

DIM	INCHES			MILLIMETERS		
	MIN	NOM	MAX	MIN	NOM	MAX
A	.031	-	.039	0.80	-	1.00
A1	.000	-	.002	0.00	-	0.05
A2	-	(.008)	-	-	(0.20)	-
b	.007	.009	.011	0.18	0.23	0.30
C	.074	.079	.083	1.87	2.02	2.12
D	.042	.048	.052	1.06	1.21	1.31
E	.114	.118	.122	2.90	3.00	3.10
e	.020 BSC			0.50 BSC		
L	.012	.016	.020	0.30	0.40	0.50
N	10			10		
aaa	.003			0.08		
bbb	.004			0.10		

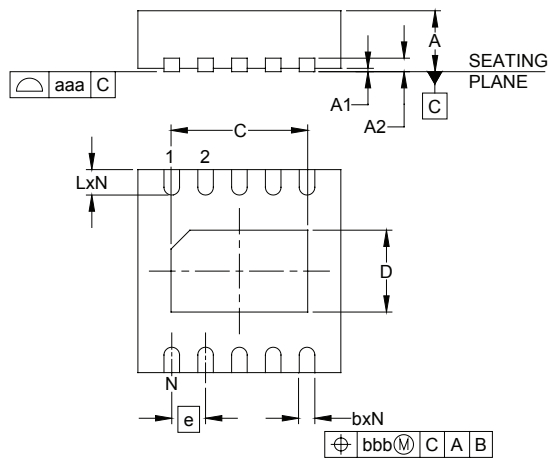

NOTES:

1. CONTROLLING DIMENSIONS ARE IN MILLIMETERS (ANGLES IN DEGREES).
2. COPLANARITY APPLIES TO THE EXPOSED PAD AS WELL AS TERMINALS.

POWER MANAGEMENT

Land Pattern - MLP-10

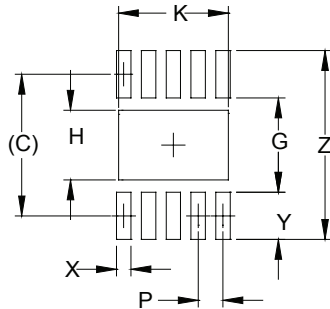

DIMENSIONS		
DIM	INCHES	MILLIMETERS
C	(.112)	(2.85)
G	.075	1.90
H	.055	1.40
K	.087	2.20
P	.020	0.50
X	.012	0.30
Y	.037	0.95
Z	.150	3.80

NOTES:

1. THIS LAND PATTERN IS FOR REFERENCE PURPOSES ONLY. CONSULT YOUR MANUFACTURING GROUP TO ENSURE YOUR COMPANY'S MANUFACTURING GUIDELINES ARE MET.

Contact Information

Semtech Corporation
 Power Management Products Division
 200 Flynn Road, Camarillo, CA 93012
 Phone: (805) 498-2111 Fax: (805) 498-3804

www.semtech.com