



BMW60N076UC1

Super Junction Power MOSFET

600 V, 52 A, 76 mΩ

Description

BMW60N076UC1 is power MOSFET using bestirpower's advanced super junction technology that can realize very low on resistance and gate charge.

It will provide much high efficiency by using optimized charge coupling technology. These user friendly devices give an advantage of Low EMI to designers as well as low switching loss.

Features

| $BV_{DSS}@T_{J,max}$ | I_D | $R_{DS(on),max}$ | $Q_{g,typ}$ |
|----------------------|-------|------------------|-------------|
| 650V | 52 A | 76 mΩ | 80 nC |

- Ultra-fast body diode.
- Extremely low losses due to very low FOM
- $R_{dson} \cdot Q_g$ and E_{oss} .
- Very high commutation ruggedness.

Applications

- PC power.
- Server power supply.
- Telecom.
- Solar inverter.
- Super charger for automobiles.

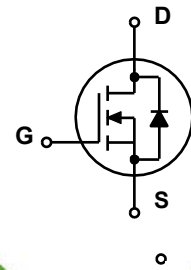
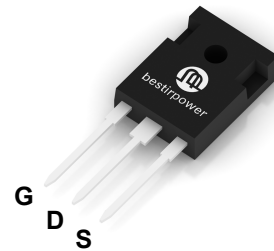

Absolute Maximum Ratings ($T_J = 25^\circ\text{C}$ unless otherwise noted)

| Symbol | Parameter | Value | Unit |
|----------------|--|---|------------------|
| V_{DSS} | Drain to Source Voltage ¹⁾ | 600 | V |
| V_{GSS} | Gate to Source Voltage | ± 30 | V |
| I_D | Drain Current ²⁾ | $V_{GS} = 10\text{ V}, (T_C = 25^\circ\text{C})$ | 52 |
| | | $V_{GS} = 10\text{ V}, (T_C = 100^\circ\text{C})$ | 33 |
| I_{DM} | Drain Current | Pulsed | 155 |
| E_{AS} | Single Pulsed Avalanche Energy ³⁾ | 625 | mJ |
| I_{AR} | Avalanche Current | 5 | A |
| dv/dt | MOSFET dv/dt | 50 | V/ns |
| | Peak Diode Recovery dv/dt ⁴⁾ | 50 | |
| P_D | Power Dissipation | ($T_C = 25^\circ\text{C}$) | 500 |
| T_J, T_{STG} | Operating and Storage Temperature Range | -55 to 150 | $^\circ\text{C}$ |
| T_L | Maximum Lead Temperature for Soldering, 1/8" from Case for 10 Seconds | 260 | $^\circ\text{C}$ |

1) Limited by T_J max. Maximum duty cycle $D=0.75$.

2) Pulse width t_p limited by T_J , max.

3) $V_{DD}=50\text{V}$, $R_G=25\Omega$, Starting $T_J=25^\circ\text{C}$.

4) $V_{DClink}=400\text{V}$; $V_{DS,peak} < V_{(BR)DSS}$; identical low side and high side switch with identical R_G .

Thermal Characteristics

| Symbol | Parameter | Value | Unit |
|-----------------|---|-------|--------------------|
| $R_{\theta JC}$ | Thermal Resistance, Junction to Case, Max. | 0.25 | $^\circ\text{C/W}$ |
| $R_{\theta JA}$ | Thermal Resistance, Junction to Ambient, Max. | 62 | |

Electrical Characteristics ($T_J = 25^\circ\text{C}$ unless otherwise noted)

| Symbol | Parameter | Test Conditions | Min | Typ | Max | Unit |
|--------|-----------|-----------------|-----|-----|-----|------|
|--------|-----------|-----------------|-----|-----|-----|------|

Off Characteristics

| | | | | | | |
|------------|-----------------------------------|--|-----|---|-----------|---------------|
| BV_{DSS} | Drain to Source Breakdown Voltage | $V_{GS} = 0\text{ V}, I_D = 1\text{ mA}$ | 600 | - | - | V |
| I_{DSS} | Zero Gate Voltage Drain Current | $V_{DS} = 600\text{ V}, V_{GS} = 0\text{ V}, T_J = 25^\circ\text{C}$ | - | - | 10 | μA |
| I_{GSS} | Gate-Source Leakage Current | $V_{GS} = \pm 30\text{ V}, V_{DS} = 0\text{ V}$ | - | - | ± 100 | nA |

On Characteristics

| | | | | | | |
|--------------|--------------------------------------|---|-----|-----|-----|----|
| $V_{GS(th)}$ | Gate Threshold Voltage | $V_{GS} = V_{DS}, I_D = 1\text{ mA}$ | 3.0 | 4.0 | 5.0 | V |
| $R_{DS(on)}$ | Static Drain to Source On Resistance | $V_{GS} = 10\text{ V}, I_D = 23\text{ A}, T_J = 25^\circ\text{C}$ | - | 70 | 76 | mΩ |

Dynamic Characteristics

| | | | | | | |
|---------------|---|--|---|------|---|----|
| C_{iss} | Input Capacitance | $V_{GS} = 0\text{ V}, V_{DS} = 50\text{ V},$ $f = 250\text{ kHz}$ | - | 3440 | - | pF |
| C_{oss} | Output Capacitance | | - | 162 | - | pF |
| C_{rss} | Reverse transfer capacitance | | - | 7 | - | pF |
| $C_{o(tr)}$ | Time Related Output Capacitance ¹⁾ | $V_{DS} = 0\text{ V to } 400\text{ V}, V_{GS} = 0\text{ V}$ | - | 557 | - | pF |
| $C_{o(er)}$ | Energy Related Output Capacitance ²⁾ | | - | 107 | - | pF |
| $Q_{g(tot)}$ | Total Gate Charge at 10 V | $V_{DD} = 400\text{ V}, I_D = 23\text{ A},$ $V_{GS} = 0\text{ to } 10\text{ V}$ | - | 80 | - | nC |
| Q_{gs} | Gate to Source Charge | | - | 19 | - | nC |
| Q_{gd} | Gate to Drain "Miller" Charge | | - | 34 | - | nC |
| $V_{plateau}$ | Gate plateau voltage | | - | 6 | - | V |

Switching Characteristics

| | | | | | | |
|--------------|---------------------|---|---|-----|---|----|
| $t_{d(on)}$ | Turn-On Delay Time | $V_{DD} = 400\text{ V}, I_D = 23\text{ A},$ $V_{GS} = 10\text{ V}$ | - | 85 | - | ns |
| t_r | Turn-On Rise Time | | - | 14 | - | ns |
| $t_{d(off)}$ | Turn-Off Delay Time | | - | 130 | - | ns |
| t_f | Turn-Off Fall Time | | - | 14 | - | ns |

Source-Drain Diode Characteristics

| | | | | | | |
|-----------|-------------------------------|--|---|------|---|---------------|
| V_{SD} | Diode Forward Voltage | $V_{GS} = 0\text{ V}, I_F = 23\text{ A}, T_J = 25^\circ\text{C}$ | - | 0.89 | - | V |
| t_{rr} | Reverse Recovery Time | $V_R = 400\text{ V}, I_F = 23\text{ A},$ $di_F/dt = 100\text{ A}/\mu\text{s}$ | - | 145 | - | ns |
| Q_{rr} | Reverse Recovery Charge | | - | 1.15 | - | μC |
| I_{rmm} | Peak reverse recovery current | | - | 14 | - | A |

- 1) $C_{o(tr)}$ is a fixed capacitance that gives the same charging time as C_{oss} while V_{DS} is rising from 0 to 400V.
- 2) $C_{o(er)}$ is a fixed capacitance that gives the same stored energy as C_{oss} while V_{DS} is rising from 0 to 400V.

Typical Performance Characteristics

Figure 1. Power dissipation

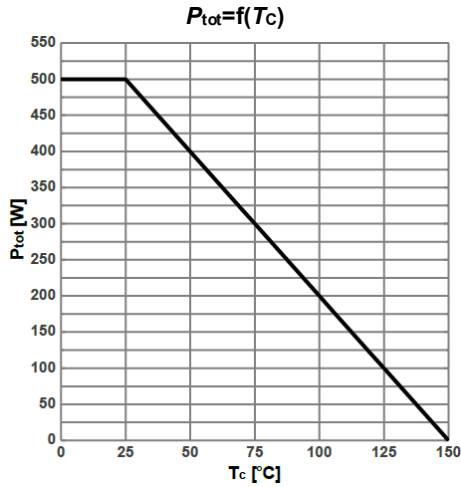

Figure 2. Max. transient thermal impedance

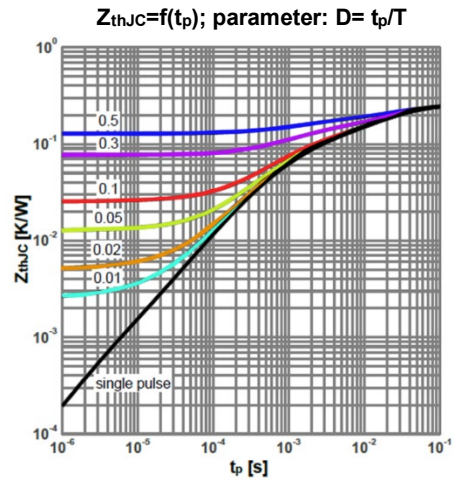

Figure 3. Safe operating area

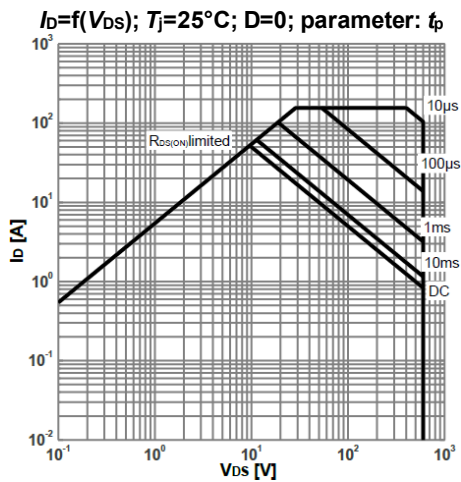

Figure 4. Typ. Output characteristics

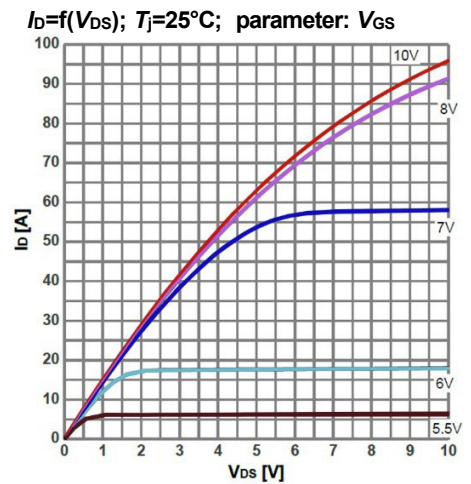

Figure 5. Typ. Output characteristics

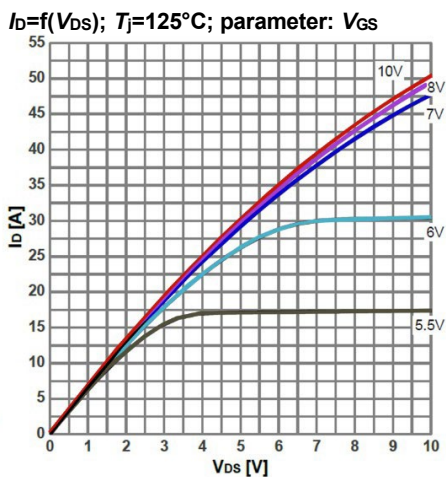
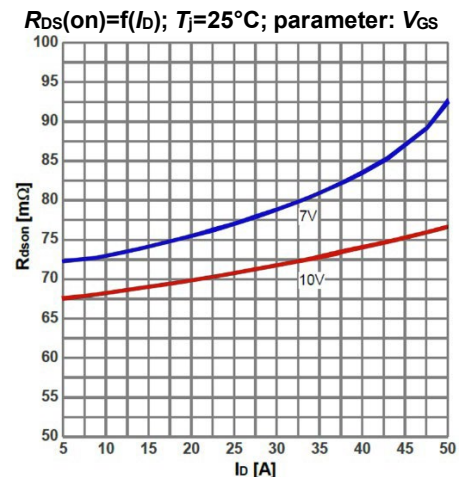

Figure 6. Typ. drain-source on-state resistance



Typical Performance Characteristics

Figure 7. Typ. drain-source on-state resistance

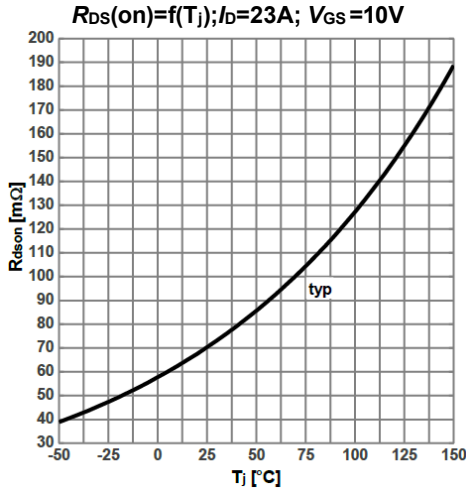

Figure 8. Typ. Transfer characteristics

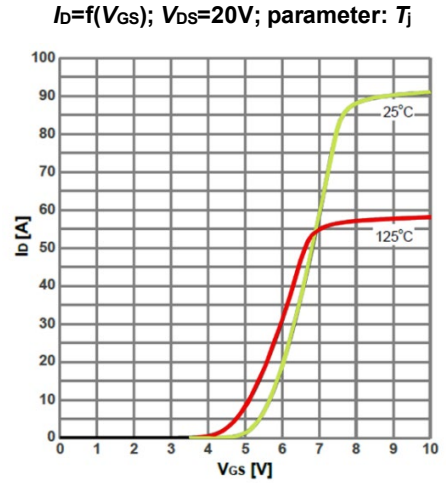

Figure 9. Typ. gate charge

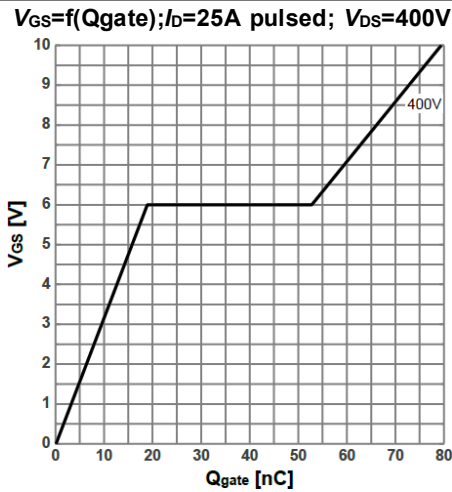

Figure 10. Typ. forward characteristics of reverse diode

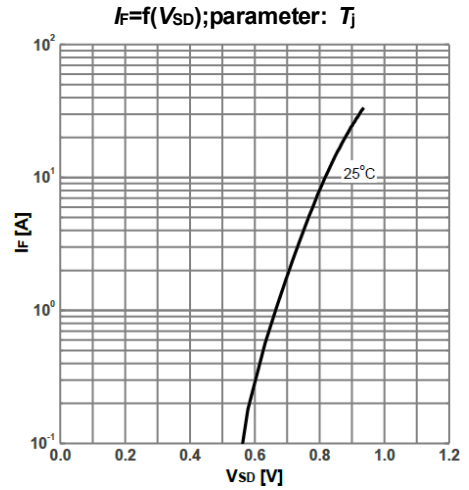

Figure 11. Typ. drain-source breakdown voltage

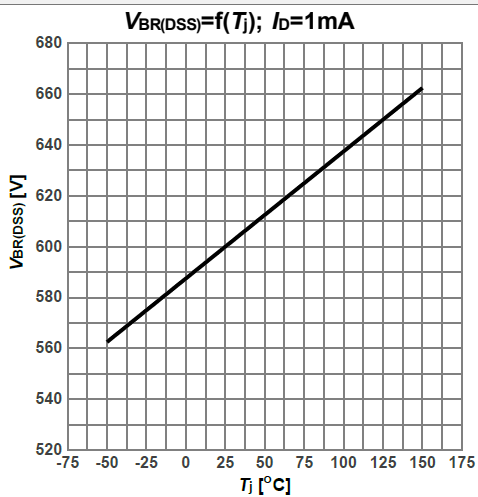
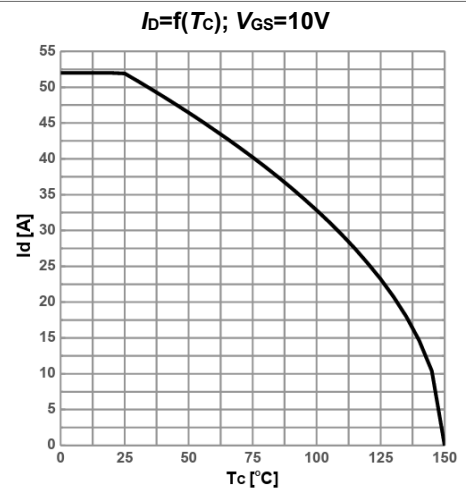

Figure 12. Maximum drain current



Typical Performance Characteristics

Figure 13. Typ. Capacitances

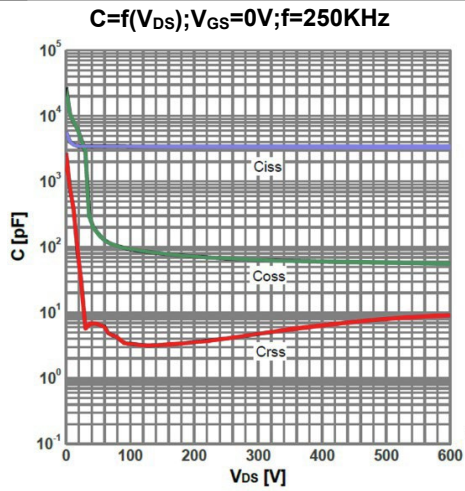
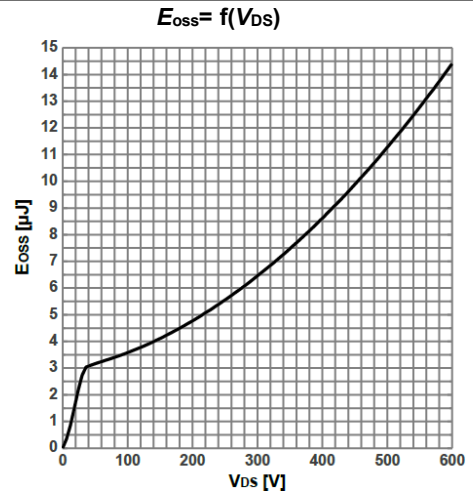

Figure 14. Typ. c_{oss} stored energy



Test Circuits

Figure 15. Diode Characteristics

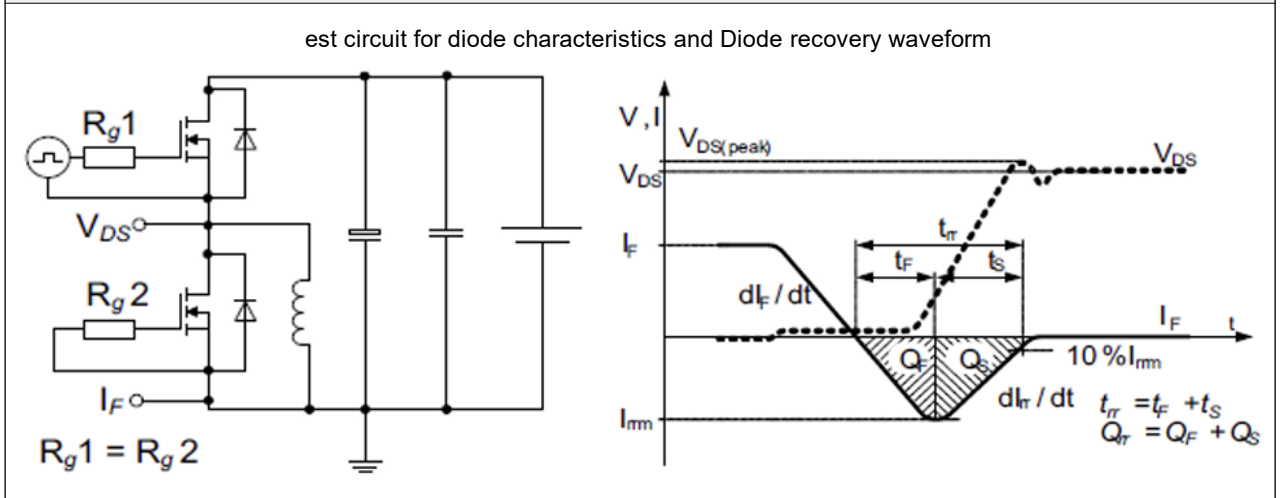

Figure 16. Switching Times

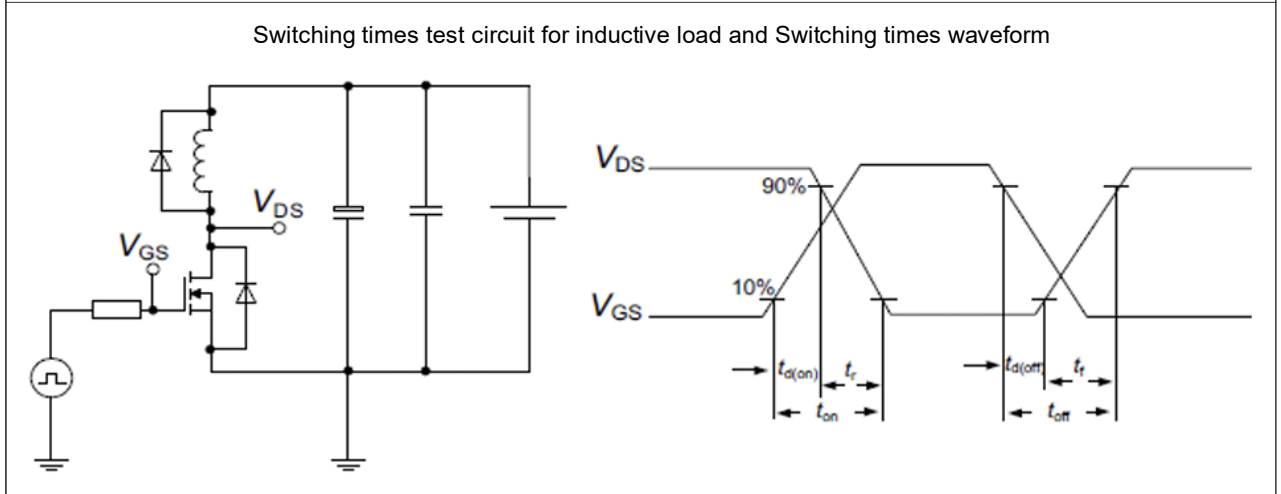
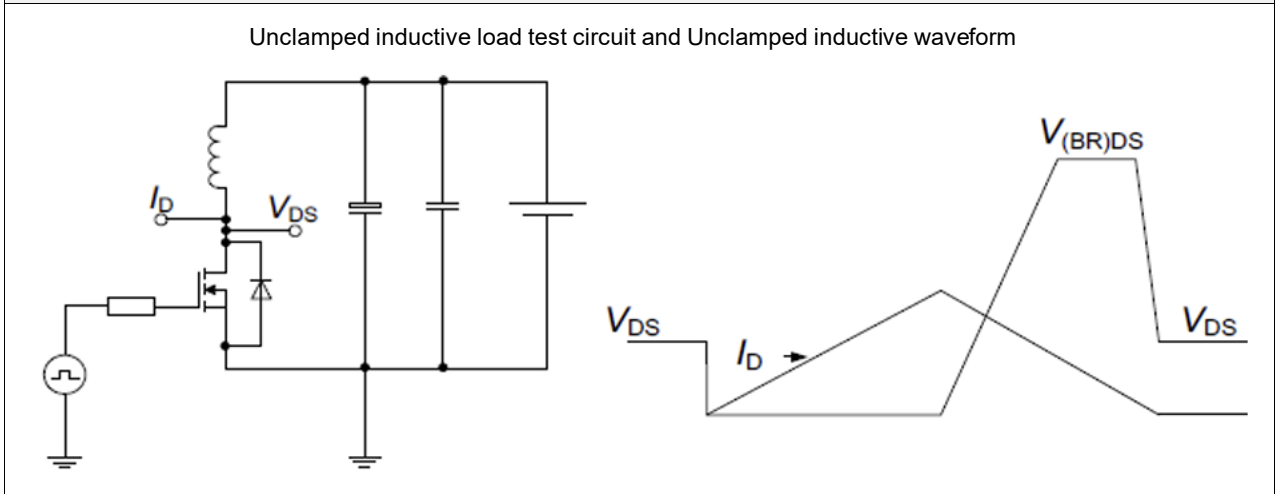
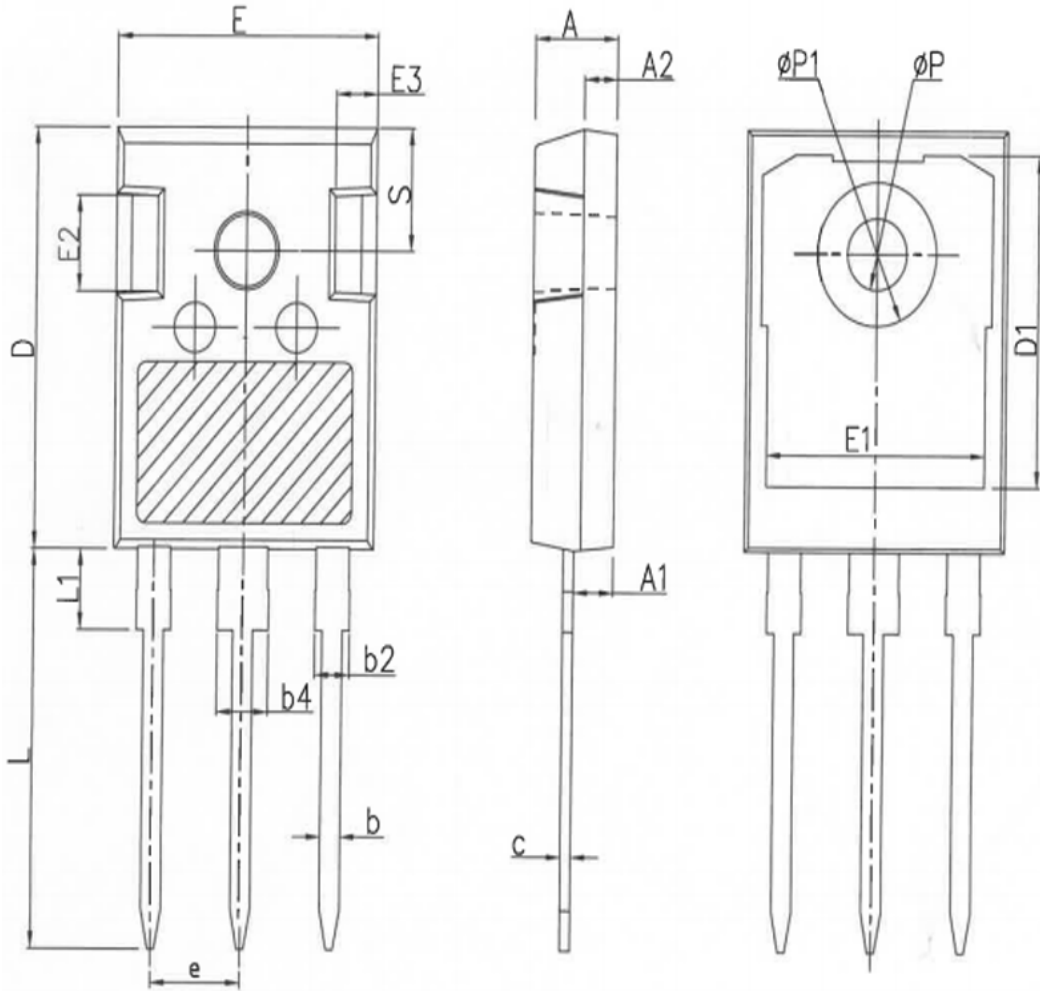

Figure 17. Unclamped Inductive Load



Package Outlines

TO247-3



COMMON DIMENSIONS

| SYMBOL | mm | | |
|--------|---------|-------|-------|
| | MIN | NOM | MAX |
| A | 4.80 | 5.00 | 5.20 |
| A1 | 2.21 | 2.41 | 2.59 |
| A2 | 1.85 | 2.00 | 2.15 |
| b | 1.11 | 1.21 | 1.36 |
| b2 | 1.91 | 2.01 | 2.21 |
| b4 | 2.91 | 3.01 | 3.21 |
| c | 0.51 | 0.61 | 0.75 |
| D | 20.70 | 21.00 | 21.30 |
| D1 | 16.25 | 16.55 | 16.85 |
| E | 15.50 | 15.80 | 16.10 |
| E1 | 13.00 | 13.30 | 13.60 |
| E2 | 4.80 | 5.00 | 5.20 |
| E3 | 2.30 | 2.50 | 2.70 |
| e | 5.44BSC | | |
| L | 19.62 | 19.92 | 20.22 |
| L1 | - | - | 4.30 |
| ΦP | 3.40 | 3.60 | 3.80 |
| ΦP1 | - | - | 7.30 |
| S | 6.15BSC | | |

* Dimensions in millimeters

Package Marking and Ordering Information

| Part Number | Top Marking | Package | Packing Method | Quantity |
|--------------|--------------|---------|----------------|----------|
| BMW60N076UC1 | BMW60N076UC1 | TO247-3 | Tube | 30 units |

Disclaimer

Bestirpower reserve the right to make changes, corrections, enhancements, modifications, and improvements to Bestirpower products and/or to this document at any time without notice.

The information given in this document shall in no event be regarded as a guarantee of conditions or characteristics. Bestirpower does not assume any liability for infringement of patents, copyrights, or other intellectual property rights of third parties by or arising from the use of Products or technical information described in this document.

This document is the property of Bestirpower Co., LTD., and not allowed to copy or transformed to other format if not under the authority approval.

© 2024 bestirpower – All rights Reserved