

一、产品型号 Product Model: LCB40PB-M

组件名称 Name of component	组件型号 Component Type	产品图片 Product Pictures
LCB40PB-M 橙色 LCB40PB-M Orange	LCB40PB-M.S.O	
LCB40PB-M 黑色 LCB40PB-M Black	LCB40PB-M.S.B	
LCB40PB-M 红色 LCB40PB-M Red	LCB40PB-M.S.R	

二、产品堆叠图 Product stacking diagram

堆叠尺寸 Outline drawing size

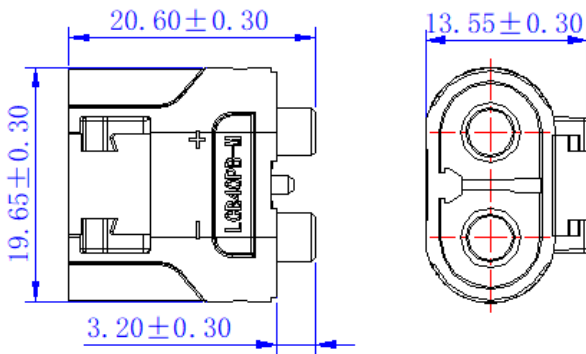

互配尺寸 Matching size

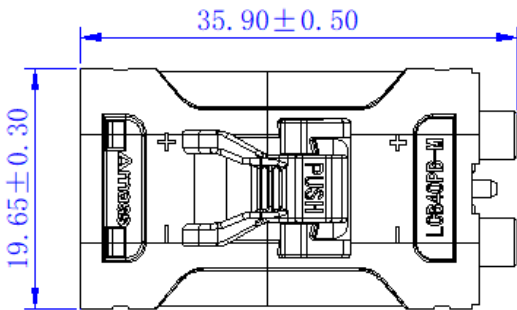

PCB LAYOUT

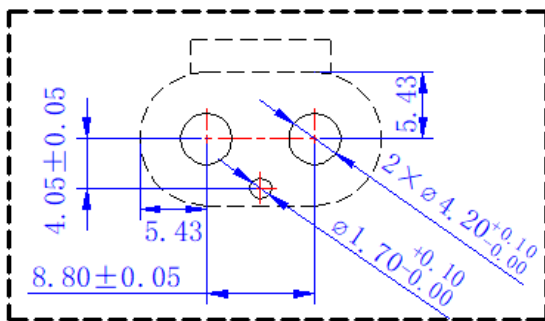

三、技术参数 Electrical SPEC.

电气特性 Electrical specifications	产品图片 Product Pictures
额定电流 Current rating	35A (10AWG 0.08mm/6.0mm ² 0.31mm ^Δ ≤30K) 30A (12AWG 0.08mm/4.0mm ² 0.31mm ^Δ ≤30K) 52A (10AWG 0.08mm/6.0mm ² 0.31mm ^Δ ≤55K) 42A (12AWG 0.08mm/4.0mm ² 0.31mm ^Δ ≤55K)
额定电压 Rated voltage	150V DC
绝缘电阻 Insulation Resistance	≥2000MΩ
接触电阻 Contact Resistance	≤0.6mΩ
机械特性 Mechanical characteristics	
使用寿命 Plug Life.	100 次 100 times
成品插入力 Insertion force	≤6.5kgf
成品拉脱力 Pull out force	≥10kgf
耐环境性 Environmental resistance	
工作温度 Work Temperature	-40°C to 120°C
阻燃等级 Materials Flame Level	UL94 V-0 (Tmin 0.8mm)
灼热丝等级 GWFI	GWFI 850°C (Tmin 0.8mm)
环保要求 Environmental	RoHS2.0、Reach、PAHS、TSCA、CP65
盐雾 Salt Spray	参照 GB/T 2423.17-2008 满足 48H Refer to GB/T 2423.17-2008 capable of 48H
材 质 Material	
外壳体 Housing	塑壳: PBT; 橙、黑、红 Plastic housing: PA: Orange, black, Red
主铜件 Metal part	紫铜 T2 Copper-T2
电镀 Plating	银 Silver
使 用 Apply	
连接方式 Connection Mode	焊接 Welding

四、运输和贮存 Transportation and storage

- 产品应贮存在清洁、干燥的环境下，库房周边不存在酸、碱或其他腐蚀性气体。
 - 产品未开袋状态下存储温度：-20°C~25°C；湿度：≤80%；储存 1 年
 - 产品如镀银件应避免光、封口密封贮存，严禁长时间空气暴露或与硫化物接触，杜绝裸手触摸。
 - 产品可适用于常规交通工具运输，运输中应避免碰撞、剧烈振动、雨雪淋袭、水浸等。
- The product should be stored in a clean and dry environment, and there should be no acidic, alkaline, or other corrosive gases around the warehouse.
 - Storage temperature of product in unopened state:- 20°C~25°C ; Humidity: ≤ 80%; Storage for 1 year
 - Products such as silver plated parts should be stored away from light, sealed, and sealed. Prolonged exposure to air or contact with sulfides is strictly prohibited, and bare hands should be avoided.
 - The product is suitable for regular transportation, and collision, severe vibration, rain and snow, water immersion, etc. should be avoided during transportation

五、注意事项 Precautions

- 请勿超出额定电流和电压使用及带电情况下拔插本连接器，以免引起事故和故障。
 - 连接器为电路连接部件，非受力部件，请勿将连接器作为结构体的一部分使用。
 - 应在规格书要求环境下使用，请勿在高温、高湿的地方使用连接器。
 - 连接器是精密部件，易变形、弯曲、脱落，请小心拆包。
- Do not exceed the rated current and voltage when using or unplugging this connector under live conditions, as it may cause accidents and malfunctions.
 - The connector is designed as the connecting part of the circuit, and not a load-bearing component. so do not use the connector as the junction of the shell, to construct part of an object.
 - The connector should be used in the environment specified in the specifications, and do not use in high temperature and humidity environment.
 - Connectors are precision components that are prone to deformation, bending, and detachment. Please be careful when unpacking.