

1.View and size(视图及尺寸)

Main technical indicators(主要技术指标)	
1.Mating (插拔次数)	5000
2.Working Temperature (温度)	-55~+150 °C
3.IP Rating (防护级别)	IP 50
4.Diameter of socket end(插合端直径)	φ0.7
5.Testing Voltage (测试电压)	950V
6.Working Voltage (工作电压)	800V
7.Rated Current (额定电流)	4.0A
8.Shell material(壳体材质)	Brass (chromium plating)/(nickel plating) fixation ring/黄铜(镀铬)/(镀镍)固定圈
9.Pin Material(插针材料)	Copper alloy gold plating(铜合金镀金)
10.Insulator material(绝缘体材质)	L:PPS P:PEEK

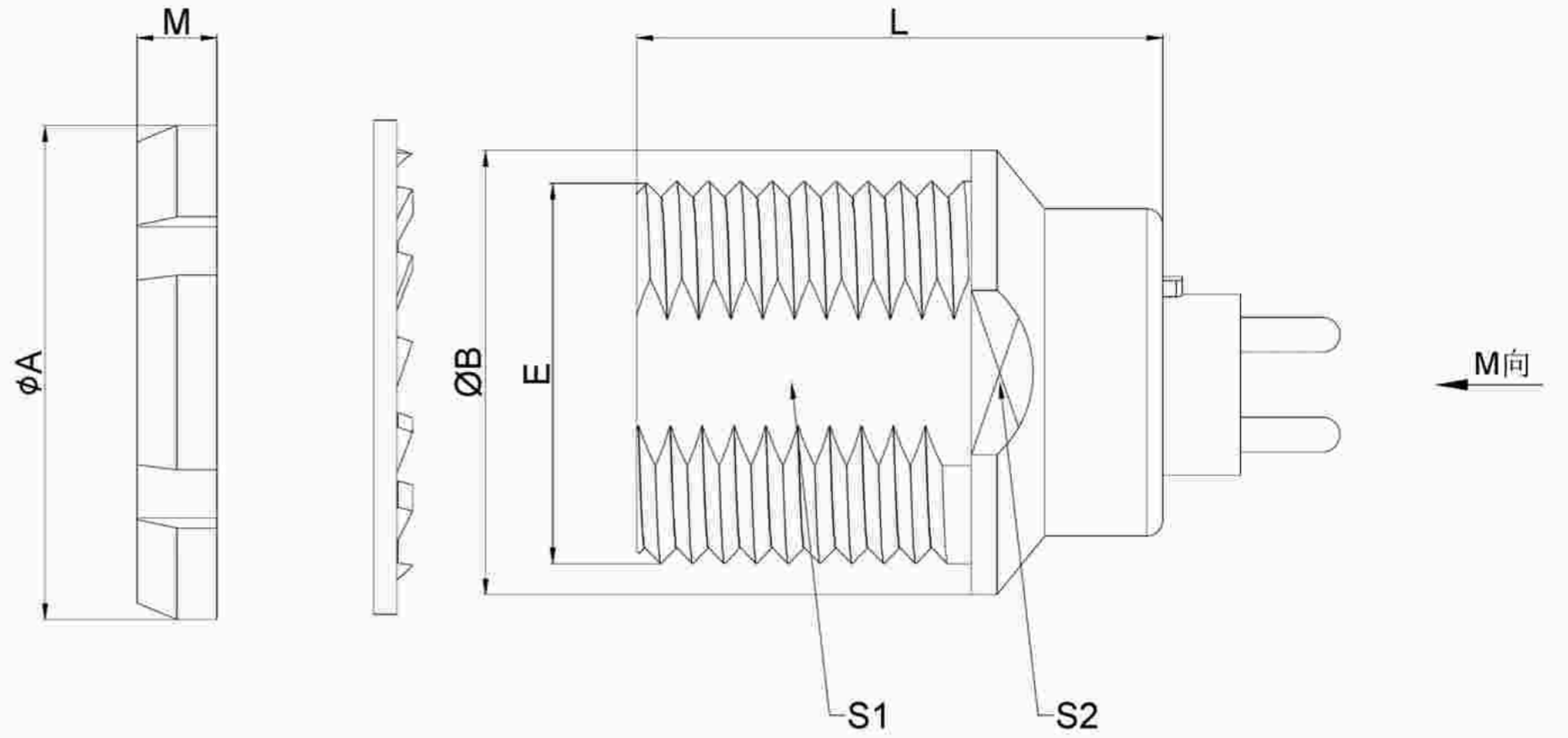

	A	B	N	L	E	M	S1	S2
MM	φ24	Ø22	25	28.5	M18*1	4.5	16.5	20
in	φ0.94	0.87	0.98	1.12		0.177	0.65	0.79

Sum up(总结)	
Series(系列)	B
Shell style/model (外壳样式/型号)	ZEG:Fixed socket, nut fixed (rear panel mounted)固定式插座, 螺母固定(后面板安装)
Button (按键)	A button(一个按键)
Termination type (终止类型)	Female print PCB(印刷PCB)
Line diameter awg(线材直径)	30-22AWG
Cable diameterφ (电缆直径)	0-0
Match plug(匹配插头)	TGG.3B.P24.CXAD92H

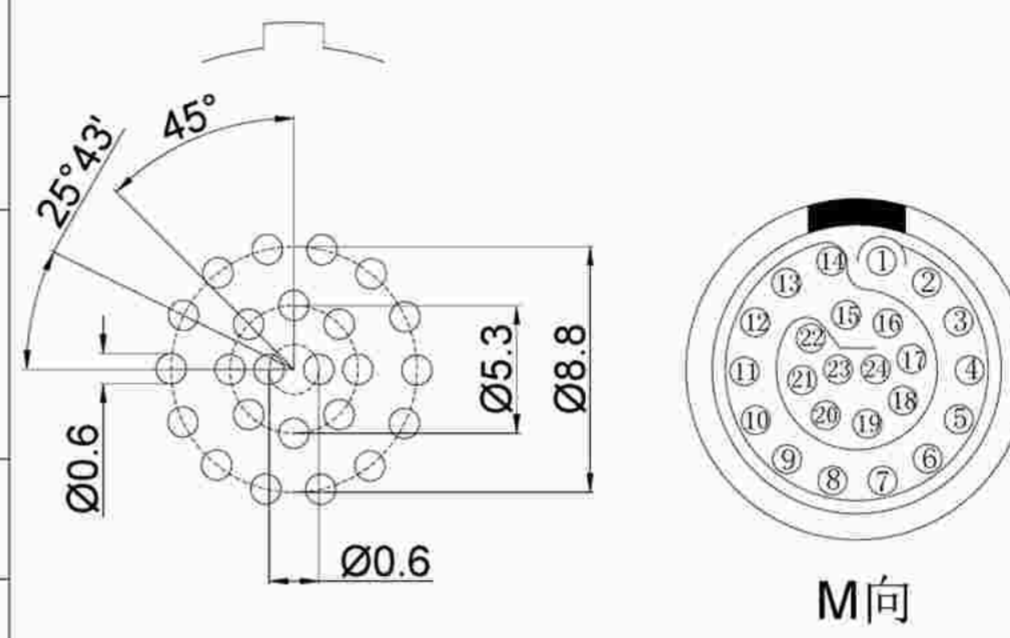

Pcb plate opening size (PCB板开孔尺寸)

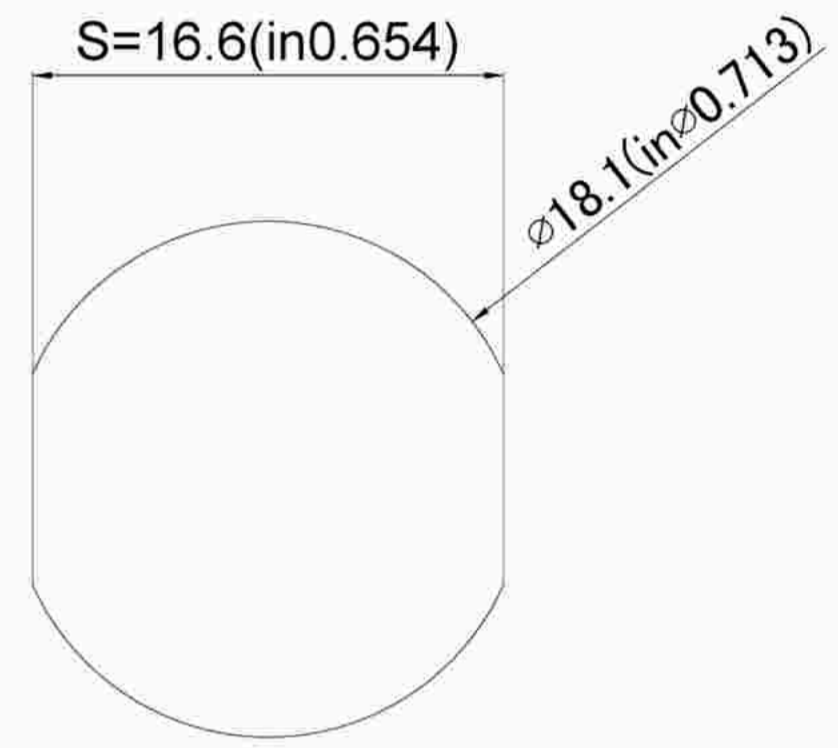

Pane hole size (面板开孔尺寸)

Location pin combination(定位销组合)			
(编号) Number	Number of positioning pins(定位销数量)	Angle(角度)	Series(系列)--3B
G	One(1)		(Zero degrees)0°
A	Two(2)	A	Thirty degrees(30°)
B	Two(2)		Forty-five degrees(45°)
C	Two(2)		Sixty degrees(60°)
D	Two(2)	γ	95 degrees (95°)
E	Two(2)	β	120 degrees(120°)
F	Two(2)		145 degrees(145°)
J	Two(2)	A	37.5degrees(37.5°)
K	Two(2)		52.5degrees(52.5°)
L	Two(2)		γ

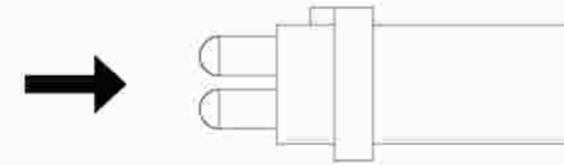

Boarded mother adhesive core (板接型母胶芯)

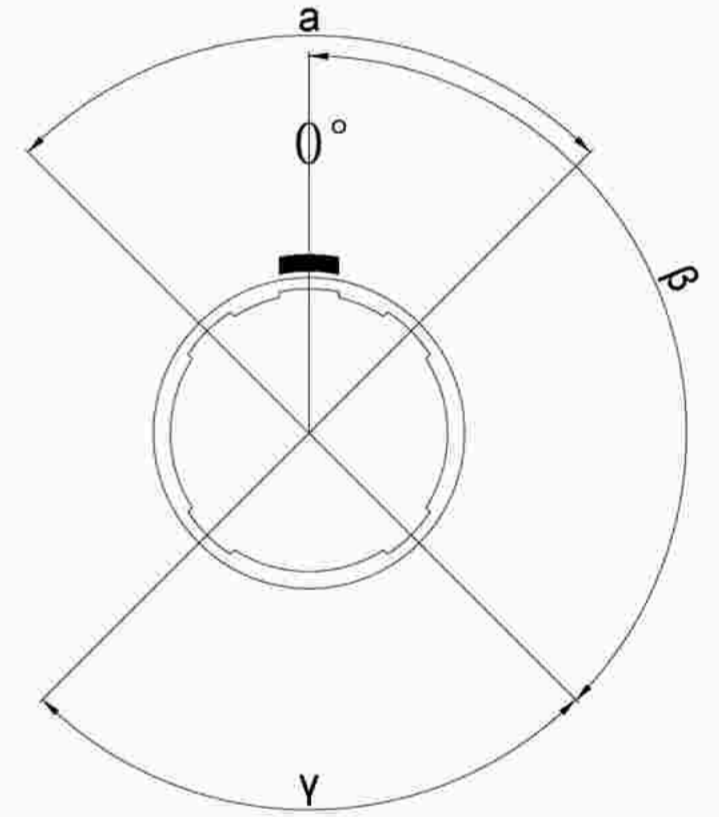

Positive view of the socket (插座正视图)

ZE G.3B.P24.C X N

Model(型号)

Positioning pin(定位销)

Series(系列)

Needle core configuration(针芯配置)

Outer casing(外壳)

Insulator(绝缘体)

Needle core(针芯)

	A	B	C√	ANGLE	
5-10	±0.02	±0.05	±0.1	0°-30°	±0.1°
50-100	±0.1	±0.15	±0.2	61°-90°	±0.5°
50-100	±0.15	±0.2	±0.25		
100-	±0.15%	±0.20%	±0.25%		

DESIGNED(设计)
广东星坤科技股份有限公司
 CHECKED(校对)
 APPROVED(审核)
生效
 REVISIONS
文件工程章

DATE(日期)	SCALE(比额)	N/A(不适用)	MODEL TYPE
DATE(日期)	VIEW(视图)		型号类型: ZEG.3B.P24.CXN
DATE(日期)	UNIT(单位)	MM	PART NO. 3B24 core socket
MATERIAL (材料)			名称: 3B24芯插座
			DWG NO.:

WEIGHT(重量)	SHEET(表)	REVISION(修订)
	1/1	A0

KKB INDUSTRIAL PRECISION CO.,LIMITED

www.helloxkb.com www.helloxkb.cn