

Smart 27 LED Driving SoC with Audio Synchronization

FEATURES

- 9 current sink and 3 current switch driving up to 27 LEDs or 9 RGBs in matrix display mode
 - Global 16 current steps, max 75mA
 - Individual 12 bit PWM dimming control
 - Individual 256 steps of constant current
- Embedded MCU, Flash ROM, reloadable lighting effect firmware for dedicated application
- Audio input, 8bit ADC, -12dB~51dB AGC for gain adjustment
- Pre-load LED lighting program
 - Flowing-water music sync lighting effect
 - Skyline breathing lighting
 - 27 independent automatic breathing light
- Cascade for multi-chip synchronization
- LED current accuracy: $\pm 10\%$
- LED matching accuracy: $\pm 10\%$
- Low dropout voltage: 100mV
- 400kHz I²C™ interface (I²C address: 0x6A/6B)
- Single power supply, 2.7V~5.5V
- FOWLP 2.00mmx2.57mmx0.635mm-30B package

GENERAL DESCRIPTION

AW22127B is a smart LED driving SoC with audio synchronization, integrated with MCU, Flash ROM, SRAM, ADC, PGA, and LED driver circuit. All lighting effect is implemented by pre-loaded firmware designed for specific application.

There are 9 constant current sinks (LED1~9) and 3 current switch (COM1~3) capable of driving up to 27 LEDs or 9 RGB LEDs in matrix display mode. Each LED has 256 current steps for brightness or color-mixing, 12-bit PWM level for dimming. When the max output current is 75mA with 1/3 cycle rate, 25mA average current is available for each LED.

Additionally, parameter configurable PGA, ADC, digital filters provide flexible sampling and process function for audio input. Unusually brilliant audio sync lighting effects could be achieved by sophisticated firmware design.

AW22127B is available in FOWLP 2.00mmX2.57mmX0.635mm-30B package, it operates from 2.7V to 5.5V over -40°C to +85°C.

TYPICAL APPLICATION CIRCUIT

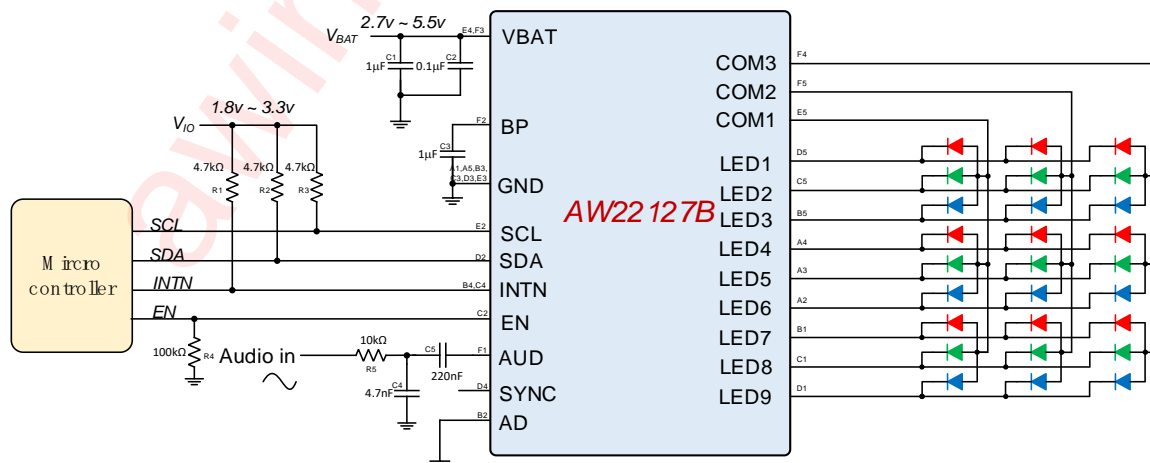

PIN CONFIGURATION AND TOP MARK

**AW22127BFOR Pin Configuration
(Top View)**

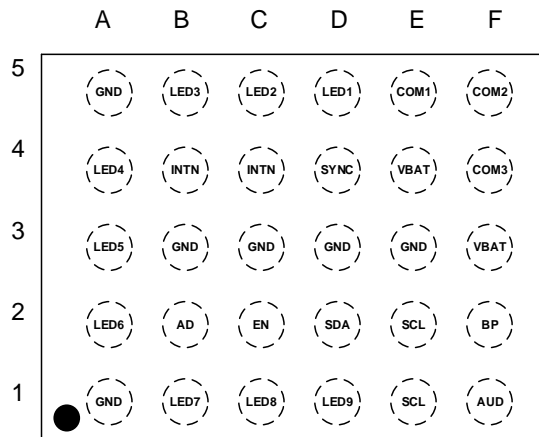

**AW22127BFOR Top Mark
(Top View)**

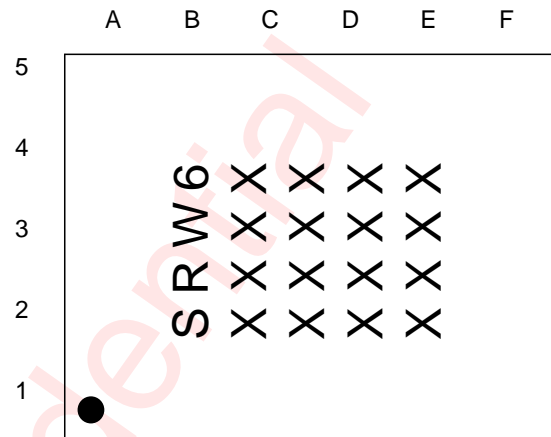

SRW6 – AW22127BFOR
XXXX – Tracing Code

AW22127B Pin Configuration and Top Mark

PIN DEFINITION

Pin No	NAME	DESCRIPTION
A1,A5,B3, C3,D3,E3	GND	Ground
A2	LED6	Constant Current Sink, connect to LED's cathode.
A3	LED5	Constant Current Sink, connect to LED's cathode.
A4	LED4	Constant Current Sink, connect to LED's cathode.
B1	LED7	Constant Current Sink, connect to LED's cathode.
B2	AD	I ² C address selection. Internally pull down to ground.
B4,C4	INTN	Interrupt pin, active low.
B5	LED3	Constant Current Sink, connect to LED's cathode.
C1	LED8	Constant Current Sink, connect to LED's cathode.
C2	EN	Enable pin. When tied to ground, the device is reset. Internally pulled down to GND with a resistor of 300kΩ.
C5	LED2	Constant Current Sink, connect to LED's cathode.
D1	LED9	Constant Current Sink, connect to LED's cathode.

D2	SDA	Serial Data I/O for I ² C Interface.
D4	SYNC	Synchronize pin, used to synchronize clock in multiple AW22127B application. Should be floated if not used.
D5	LED1	Constant Current Sink, connect to LED's cathode.
E1,E2	SCL	Serial Clock Input for I ² C Interface.
E4,F3	VBAT	Power Supply (2.7V-5.5V).
E5	COM1	Current Switch connect to LED's anode in matrix display mode.
F1	AUD	Audio in, ac-coupled input
F2	BP	LDO output, externally connect 1uF bypass capacitor.
F4	COM3	Current Switch connect to LED's anode in matrix display mode.
F5	COM2	Current Switch connect to LED's anode in matrix display mode.

FUNCTIONAL BLOCK DIAGRAM

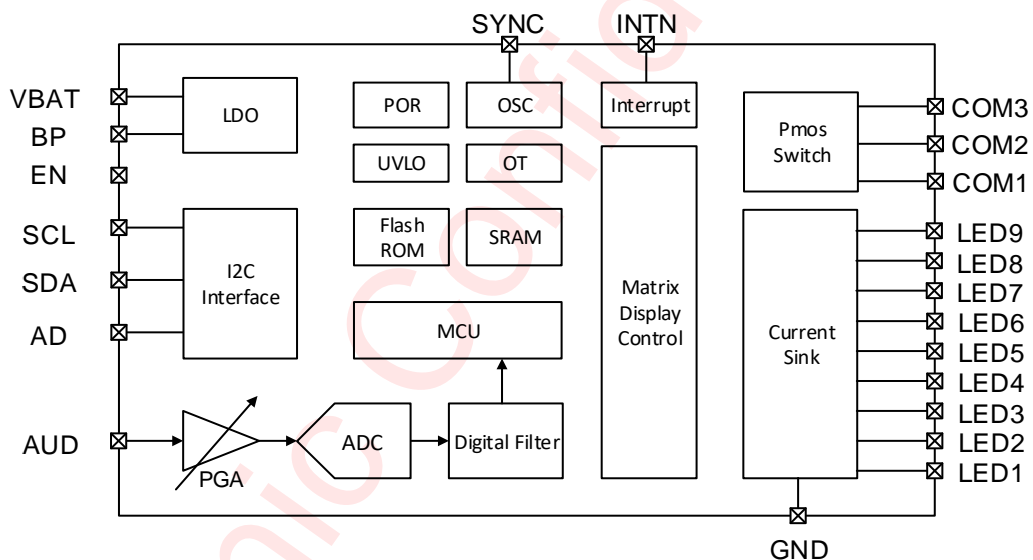

Figure 1 Function Block

TYPICAL APPLICATION CIRCUITS

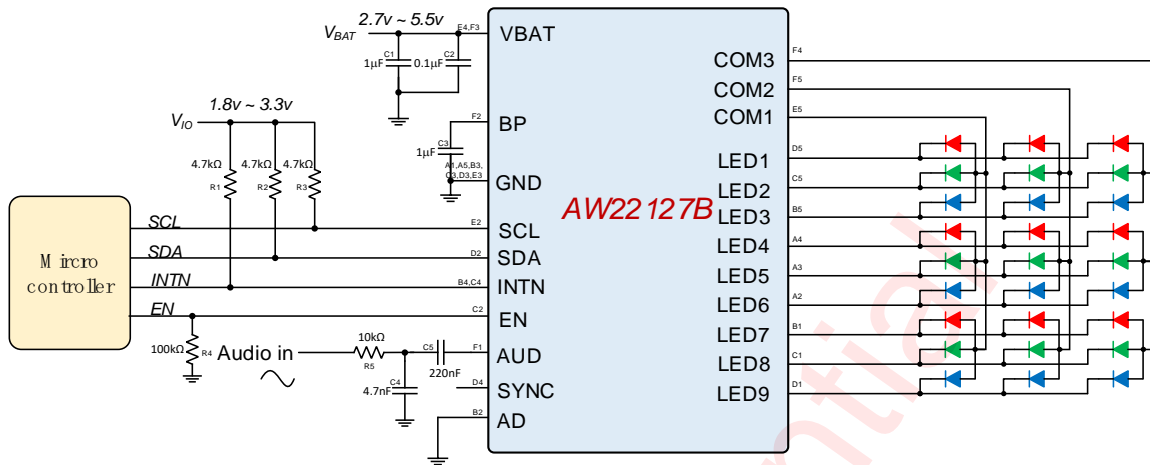

Figure 2 Application of 9 RGB LED driven by single AW22127B

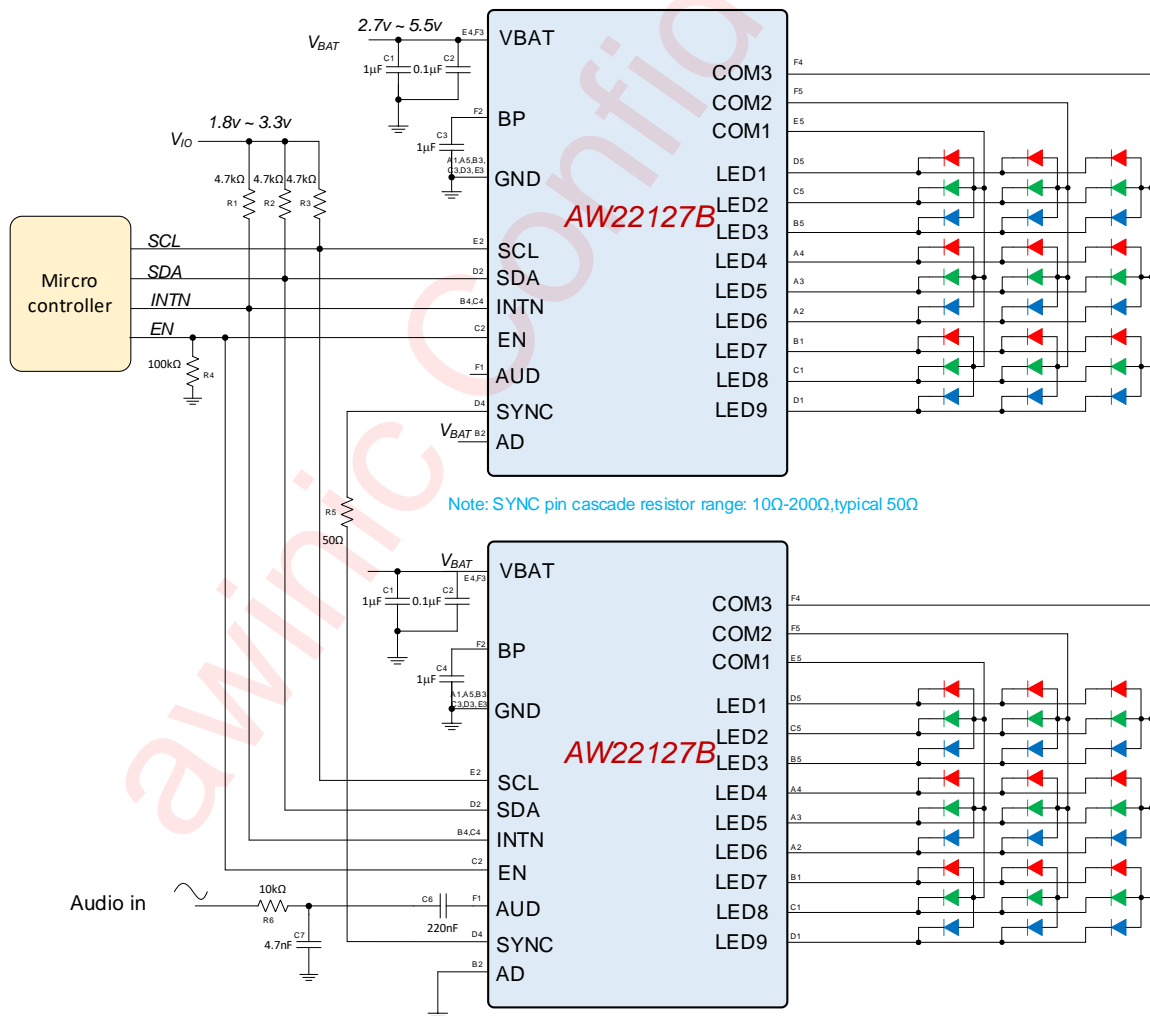
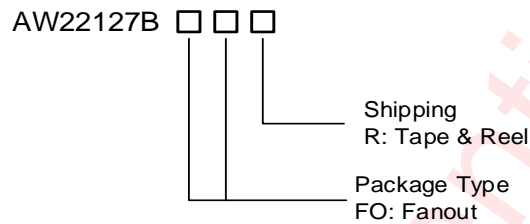

Figure 3 Application of 18 RGB LEDs driven by dual AW22127B

ORDERING INFORMATION

Part Number	Temperature	Package	Marking	Moisture Sensitivity Level	Environmental Information	Delivery Form
AW22127BFOR	-40°C~85°C	FOWLP 2.00mmX2.57 mmX0.635mm -30B	SRW6	MSL1	ROHS+HF	6000 units/ Tape and Reel



ABSOLUTE MAXIMUM RATINGS (NOTE 1)

PARAMETERS		RANGE
Supply voltage range V_{BAT}		-0.3V to 6.0V
Input voltage range	SCL, SDA,EN,AD	-0.3V to 6.0V
	LED1~LED9,COM1~COM3	-0.3V to 6.0V
Output voltage range	SDA,INTN	-0.3V to 6.0V
Junction-to-ambient thermal resistance θ_{JA}		53°C/W
Operating free-air temperature range		-40°C to 85°C
Maximum Junction temperature T_{JMAX}		150°C
Storage temperature T_{STG}		-65°C to 150°C
Lead Temperature (Soldering 10 Seconds)		260°C
ESD(NOTE 2)		
HBM		±2000V
CDM		±2000V
Latch-up		
Test Condition: JEDEC STANDARD NO.78E SEPTEMBER 2016		±350mA

NOTE1: Conditions out of those ranges listed in “absolute maximum ratings” may cause permanent damages to the device. In spite of the limits above, functional operation conditions of the device should within the ranges listed in “recommended operating conditions”. Exposure to absolute-maximum-rated conditions for prolonged periods may affect device reliability.

NOTE2: The human body model is a 100pF capacitor discharged through a 1.5kΩ resistor into each pin. Test method: MIL-STD-883J Method 3015.9. CDM test method: JEDEC EIA/JESD22-C101F.

ELECTRICAL CHARACTERISTICS

$V_{BAT}=3.8V$, $T_A=25^{\circ}C$ for typical values (unless otherwise noted)

Symbol	Description	Test Conditions	Min	Typ.	Max	Units
Power Supply						
V_{BAT}	Input operation voltage		2.7		5.5	V
$I_{SHUTDOWN}$	Current in Shutdown mode	EN=0V			1	μA
$I_{STANDBY}$	Current in Standby mode	EN=1.8V, GCR.CHIPEN=0		7	15	μA
I_{ACTIVE}	Quiescent Current in Active mode	EN=1.8V , GCR.CHIPEN=1 MCU off, display off without LEDs	0.4	0.6	1	mA
		EN=1.8V , GCR.CHIPEN=1 MCU off , display on without LEDs	0.8	1.1	1.5	mA
		EN=1.8V , GCR.CHIPEN=1 MCU enable, display on without LEDs	1.4	1.8	2.5	mA
V_{POR_BAT}	POR voltage of VBAT			1.75		V
V_{POR_LDO}	POR voltage of LDO			1.0		V
V_{UVLO}	UVLO voltage	Register UVTHR 0x10=0x03 (default)	-7%	2.2	+7%	V
V_{UVLO_HYS}	UVLO hysteresis			0.1		V
T_{OTP}	Over temperature protect			150		$^{\circ}C$
T_{HYS}	OT hysteresis			20		$^{\circ}C$
F_{OSC}	Oscillator Frequency		-5%	24.576	+5%	MHz
LED Driver						
I_{LED}	Sink current of LEDx	$I_{MAX}=75mA$, PWM=255, CURRENT=255 for LEDx	0	-	75	mA
I_{ACC}	Current accuracy	$I_{LED}=8\sim 75mA$	-10%		+10%	%

		$I_{LED}=2\sim 6mA$	-15%		+15%	%
I_{MATCH}	Matching accuracy	$I_{LED}=8\sim 75mA$	-10%		+10%	%
		$I_{LED}=2\sim 6mA$	-15%		+15%	%
V_{DROP1}	Dropout voltage for LEDx	$I_{LED}=15mA$		100	130	mV
		$I_{LED}=20mA$		130	160	mV
		$I_{LED}=30mA$		150	190	mV
		$I_{LED}=75mA$		250	320	mV
V_{DROP2}	Dropout voltage for COMx	$I_{LED}=9*10=90mA$		45	60	mV
		$I_{LED}=9*20=180mA$		90	120	mV
		$I_{LED}=9*75=675mA$		350	420	mV
F_{PWM}	PWM frequency	Register PWM_FREQ=0, Matrix mode, 3 COM ports	-5%	375	+5%	Hz
Digital Logical Interface						
V_{IL}	Logic input low level	AD,EN,SDA,SCL,SYNC			0.4	V
V_{IH}	Logic input high level	AD,EN,SDA,SCL,SYNC	1.3			V
I_{IL}	Low level input current	SDA,SCL,SYNC		5		nA
I_{IH}	High level input current	SDA,SCL,SYNC		5		nA
V_{OL}	Logic output low level	SDA,INTN, $I_{OUT}=3mA$			0.4	V
I_L	Output leakage current	SDA,INTN open drain			1	nA

I²C INTERFACE TIMING

Parameter Name		Min	Typ.	Max	Units
F _{SCL}	Interface Clock frequency			400	kHz
T _{DEGLITCH}	Deglitch time	SCL	200		ns
		SDA	250		ns
T _{HD:STA}	(Repeat-start) Start condition hold time	0.6			μs
T _{LOW}	Low level width of SCL	1.3			μs
T _{HIGH}	High level width of SCL	0.6			μs
T _{SU:STA}	(Repeat-start) Start condition setup time	0.6			μs
T _{HD:DAT}	Data hold time	0			μs
T _{SU:DAT}	Data setup time	0.1			μs
T _R	Rising time of SDA and SCL			0.3	μs
T _F	Falling time of SDA and SCL			0.3	μs
T _{SU:STO}	Stop condition setup time	0.6			μs
T _{BUF}	Time between start and stop condition	1.3			μs

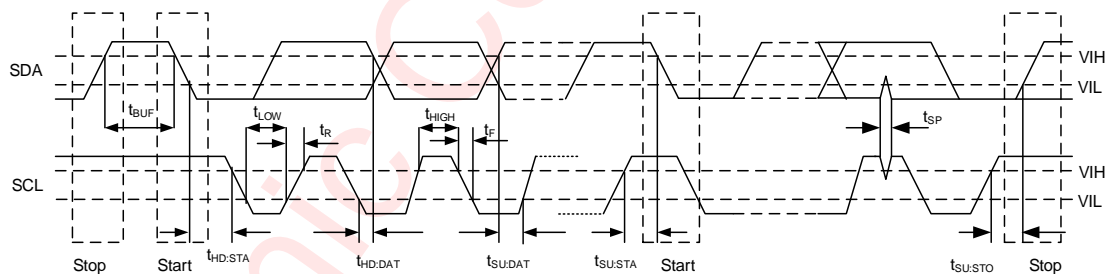

Figure 4 I²C Timing Parameters

FUNCTIONAL DESCRIPTION

POWER-ON-RESET

Upon initial power-up, the AW22127B is reset by internal power-on-reset, and all register are reset to default value, and LED driver is shut down.

Once the supply voltage VBAT drops below the threshold voltage V_{POR_VBAT} (1.75V), or the LDO output voltage is below V_{POR_LDO} (1.0V), the power-on-reset will be activated to reset the device again.

OPERATING MODE

After power-up, if external pin EN is low, the device keeps in shut-down state. In shut-down state, all internal circuit do not work, I²C interface is closed and the power current consumption is very low (<1 μ A).

If pin EN is pulled high, the device enters stand-by state. In Standby state, only part of the internal circuit can work: the LDO works in low-power mode, the OSC still keeps closed, and I²C interface is opened. The current consumption in stand-by state is less than 10 μ A. When bit CHIPEN of GCR register is set to 1 in standby mode, AW22127B enters into active mode.

In active state, the internal LDO switch to full-load mode, and the OSC starts to work to provide stable clock signal. User can configure the device via I²C interface, invoke MCU to run specified pre-loaded MCU program to produce expected lighting effect.

Below is the recommended operation timing:

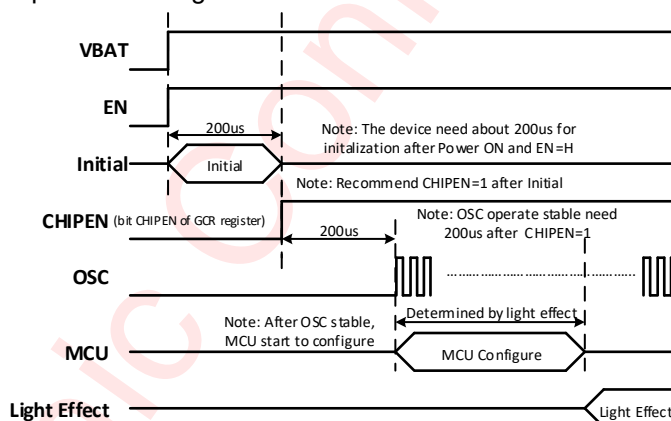

In **active** state, If register GCR.CHIPEN is set to 0, the device return to standby state, and all LED drive will be turn off.

SOFTWARE RESET

Writing 0x55 to register SRSTR (register: 0x01) via I²C interface will reset the device, including all internal circuits and configuration registers. After the software reset command is input through I2C, it needs to wait at least 2ms before any other I2C command can be accepted.

UNDER VOLTAGE LOCK OUT (UVLO)

The voltage on pin VBAT is monitored internally by the AW22127B. When voltage of VBAT drops below predefined threshold (2.2v typically, register UVTHR configurable, address 0x10), the bit UIS is set to 1 in ISR register (address 0x0A). After a read, the register ISR can be cleared.

If both bit UVME and UVLOE in register GCR (address 0x02) are set, when UVLO condition is met, the bit CHIPEN in register GCR will be cleared, all current lighting effect is halted, and the device will be forced to standby state.

The bit UVLME enables or disables UVLO monitor, the bit UVLOE control the protection function of UVLO turn on or off. By default, both bits are 0, both UVLO monitor and protection are switched on.

OVER TEMPERATURE PROTECTION

When the device reaches 150°C, the over-temperature protection be activated, and the bit OIS is set to “1” in register ISR (address 0x0A), and after a read, the register ISR can be cleared. The bit OTMD and bit OTPD in register GCR (address 0x02) control OT monitor and OTP protection function enabled and disabled respectively. By default, both OT monitor and OTP protection are enabled.

When Over Temperature (OT) condition is met and OTP is enabled, the bit CHIPEN in register GCR will be cleared, all current lighting effect is halted, and the device will be forced to standby state.

INTERRUPT

Interrupt function is provided on pin INTN. When interrupt status is set in register ISR and corresponding interrupt enable bit is set, interrupt occurs.

There are two kind of interrupt mode: Level mode and Pulse mode.

If bit INTMD in register ICR (address 0x08) is 0, Level mode is active, and INTN is pulled low when interrupt takes place, it will keeps until register ISR is read via I²C interface.

If bit INTMD is set, Pulse mode is active, pin INTN outputs a negative pulse when interrupt occurs. The width of pulse is configured by bits INTWTH in register ICR.

In AW22127B, there are 8 interrupt sources, they are all enabled or disabled by register IER (address 0x09).

I²C INTERFACE

AW22127B supports the I²C serial bus and data transmission protocol in fast mode at 400kHz. AW22127B operates as a slave on the I²C bus. Connections to the bus are made via the open-drain I/O pins SCL and SDA. The pull-up resistor can be selected in the range of 1k~10kΩ and the typical value is 4.7kΩ. AW22127B can support different high level (1.8V~3.3V) of this I²C interface.

DEVICE ADDRESS

The I²C device address (7-bit) of AW22127B is 0x6A (pin AD is low) or 0x6B (pin AD is high), followed by the R/W bit (Read=1/Write=0).

DATA VALIDATION

When SCL is high level, SDA level must be constant. SDA can be changed only when SCL is low level.

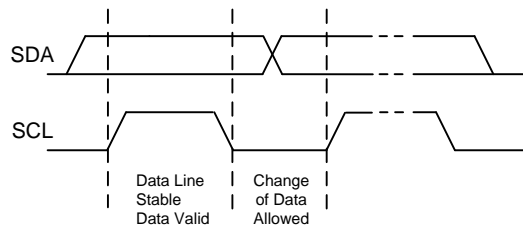

Figure 5 Data Validation Diagram

I²C START/STOP

I²C start: SDA changes from high level to low level when SCL is high level.

I²C stop: SDA changes from low level to high level when SCL is high level.

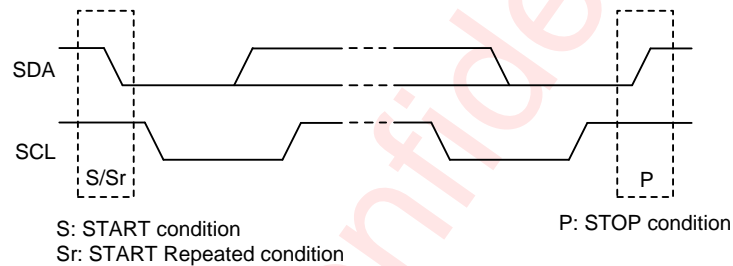

Figure 6 I²C Start/Stop Condition Timing

ACK (ACKNOWLEDGEMENT)

ACK means the successful transfer of I²C bus data. After master sends 8bits data, SDA must be released; SDA is pulled to GND by slave device when slave acknowledges.

When master reads, slave device sends 8bit data, releases the SDA and waits for ACK from master. If ACK is send and I²C stop is not send by master, slave device sends the next data. If ACK is not send by master, slave device stops to send data and waits for I²C stop.

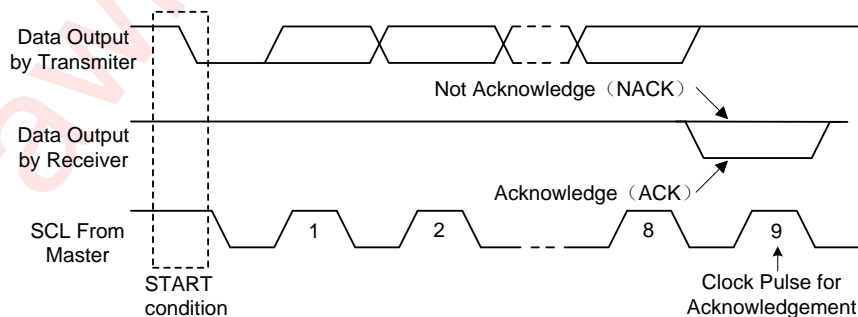

Figure 7 I²C ACK Timing

WRITE CYCLE

One data bit is transferred during each clock pulse. Data is sampled during the high state of the serial clock (SCL). Consequently, throughout the clock's high period, the data should remain stable. Any changes on the SDA line during the high state of the SCL and in the middle of a transaction, aborts the current transaction. New data should be sent during the low SCL state. This protocol allows a single data line to transfer both command/control information and data using the synchronous serial clock.

Each data transaction is composed of a Start Condition, a number of byte transfers (set by the software) and a Stop Condition to terminate the transaction. Every byte written to the SDA bus must be 8 bits long and is transferred with the most significant bit first. After each byte, an Acknowledge signal must follow.

In a write process, the following steps should be followed:

- 1) Master device generates START condition. The "START" signal is generated by lowering the SDA signal while the SCL signal is high.
- 2) Master device sends slave address (7-bit) and the data direction bit (R/W = 0).
- 3) Slave device sends acknowledge signal if the slave address is correct.
- 4) Master sends control register address (8-bit)
- 5) Slave sends acknowledge signal
- 6) Master sends data byte to be written to the addressed register
- 7) Slave sends acknowledge signal
- 8) If master will send further data bytes the control register address will be incremented by one after acknowledge signal (repeat step 6,7)
- 9) Master generates STOP condition to indicate write cycle end



Figure 8 I²C Write Byte Cycle

READ CYCLE

In a read cycle, the following steps should be followed:

- 1) Master device generates START condition
- 2) Master device sends slave address (7-bit) and the data direction bit (R/W = 0).
- 3) Slave device sends acknowledge signal if the slave address is correct.
- 4) Master sends control register address (8-bit)
- 5) Slave sends acknowledge signal
- 6) Master generates STOP condition followed with START condition or REPEAT START condition
- 7) Master device sends slave address (7-bit) and the data direction bit (R/W = 1).
- 8) Slave device sends acknowledge signal if the slave address is correct.

- 9) Slave sends data byte from addressed register.
- 10) If the master device sends acknowledge signal, the slave device will increase the control register address by one, then send the next data from the new addressed register.
- 11) If the master device generates STOP condition, the read cycle is ended.

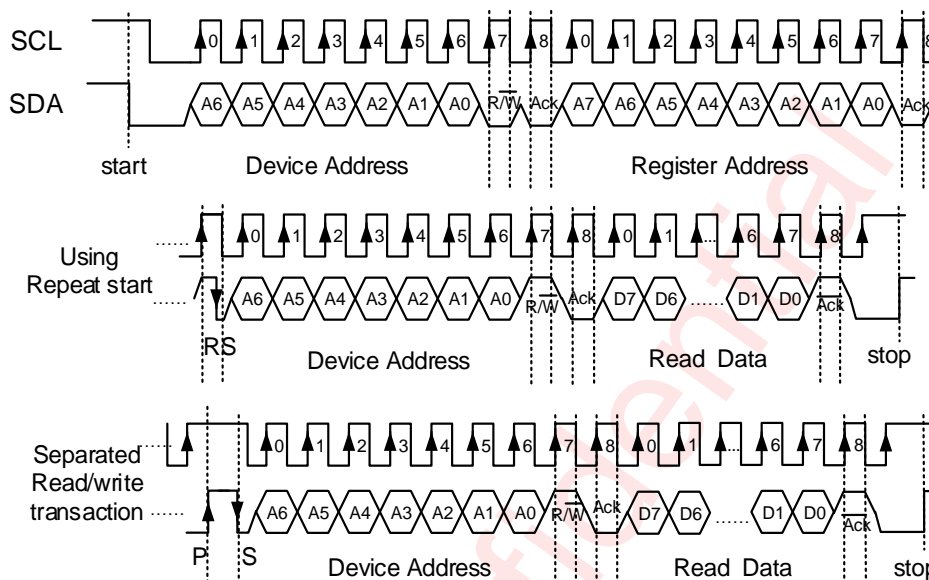

Figure 9 I²C Read Byte Cycle

MCU AND PROGRAM CONTROL

AW22127B integrated an 8bit MCU, 18kB Flash ROM and 1kB SRAM. Along with these peripherals such as timer, watchdog, audio sample/process module, LED matrix display control module, a flexible, powerful and LED application-oriented system-on-chip (SoC) platform is built. Upon the SoC platform, all lighting effect are implement by MCU, user can design different firmware program according to different application.

Via I²C interface, external controller can download or update new firmware into internal Flash ROM, and control embedded MCU to execute or stop certain functional program conveniently by send task message to register TASK0 and TASK1 (address 0x05,0x06).

By default, the operating frequency of MCU is 24.576MHz, which can be configured via bits FREQ[3:0] in register CLKCR (address 0x03), the lowest frequency is 1.024MHz. The lower the operating frequency, the less the power consumption by MCU.

LED MATRIX CONTROL MODULE

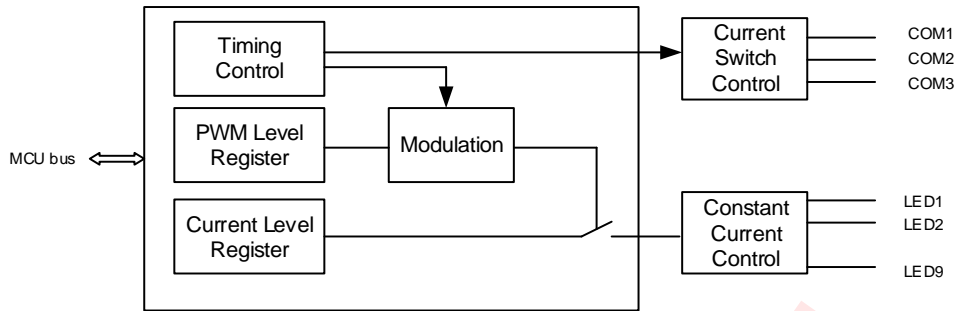

Figure 10 LED Matrix Display Control Module

There are 9 constant current sink (LED1~ LED9) and 3 current switches (COM1~COM3). In matrix display mode, the device can drive 27 single-color LEDs or 9 RGB LED.

Each LEDx has 256 steps of constant current and 12 bit/4096 levels PWM duty cycle controlled by MCU, 3 COM pins are also controlled by MCU to drive PMOS current switches in time-division mode. In matrix display mode, MCU updates the current, PWM level for each LED periodically, and switches on COM1, COM2, COM3 in turn to generate animation lighting effect.

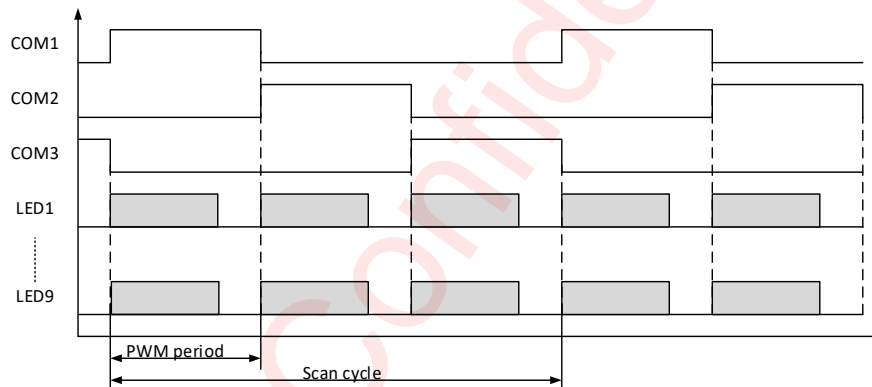

Figure 11 Scan Timing in Matrix Display Mode

LED CURRENT

Globally, the maximum output current (I_{MAX}) for all LEDs is set by register IMAX (address 0x0b), which only can be set via I²C interface. The 4 bit max current option provides 16 level current adjustment from 2mA to 75mA (refer to register description of IMAX)

Individual LED is 8bit /256 steps of current selectable, which only can be set by internal MCU according to dedicated lighting effect program in firmware. In RGB application, different current level for R,G and B LED can form to different color mixed, so totally 256x256x256 color-mixing schemes is available.

If the max output current is I_{MAX} , and 8bit current level is M_{SET} for LEDx, the practical constant current I_{OX} for LEDx could be denoted as:

$$I_{OX} = I_{MAX} * M_{SET}/255 (M_{SET} = 0\sim255)$$

PWM DIMMING CONTROL

Besides of 256 steps of constant current for individual LED, 12bit/4096 levels of PWM is provided for each LED.

The frequency of PWM modulation only can be set by MCU. Every PWM period, and internal interrupt is generated to inform MCU to update the value of current and PWM for each LED as well as change active current switch among 3 COM pin.

Generally, PWM level is used for dimming adjustment, the ramp curve of PWM transition can be arbitrarily set by firmware program in AW22127B. Usually exponential curve is applied, different transition curve create different blinking or breathe lighting effect.

AUDIO SAMPLE AND PROCESS

When bit AUDE in register AUDCTR (address 0x0C) is set, the integrated audio process block is enabled, which contains a programmable-gain amplifier (PGA), an 8-bit ADC and a digital process module.

The block diagram of audio sample and process path is shown in the figure below.

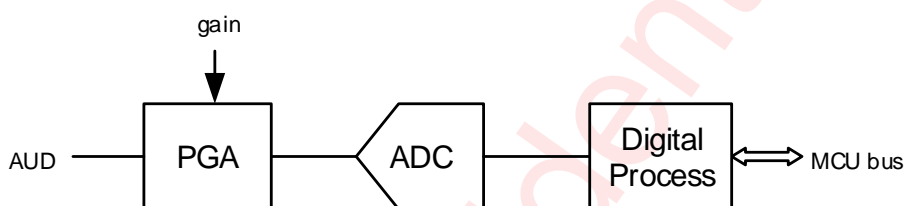

Figure 12 Audio sample and process path

The analogue audio signal is AC-coupled to pin AUD with an external DC blocking capacitor, and then amplified by PGA. An 8bit ADC converted amplified analog signal to digital code, and then sent to digital process block for filter and analysis. The output of digital process block can be accessed by MCU for further processing for lighting effect generation.

The common mode voltage of PGA is 1.0V, and the input voltage range on pin AUD is 0V to 2.0 V.

The PGA gain is set by an internal 6bit register that is only controlled by MCU, the adjustable range of gain is from -12 dB to +51dB, 1dB/Step. Auto-gain-control (AGC) function is implemented by software algorithm, which adjust gain setting in real-time according to the calculation results of input signal's peak and power.

The sampling rate of ADC is also set by MCU. After a sample obtained, an external interrupt request will be sent to MCU, and MCU responses to this interrupt and read back the sampled data for further process.

The audio synchronized lighting effect is determined by software completely. User can flexibly design program, modify not only current (color) but PWM level (brightness) also to achieve attractive effect.

FIRMWARE PROGRAM

In the AW22127B, the user-programmable Flash ROM space is 17.5kB, which is divided into two area: the main array area (16kB) and the sub-array area (1.5kB). The address of the two area are continuous, and both can be used to store user program. The Flash ROM can be erased, burned, and verified through the I²C interface.

The main array area supports chip erase and sector (512Byte) erase, while the sub-array area only supports sector erase. Flash erase is the process of changing the storage content from 0 to 1. Programming can only burn flash data from 1 to 0, but not from 0 to 1. Before flash programming, it must be erased first.

The AW22127B supports two programming modes: single-byte programming and sequential multi-byte programming. The single-byte programming mode does not require I²C interface rate, both 100kHz and 400kHz rate are permitted. As the Flash ROM limits the maximum programming accumulation time allowed on the same row, the sequential multi-byte programming mode only can be adopted in 400kHz I²C interface. In application of 100kHz I²C interface only single byte programming mode are recommended.

The following diagrams show the I²C operating flow for different programming modes.

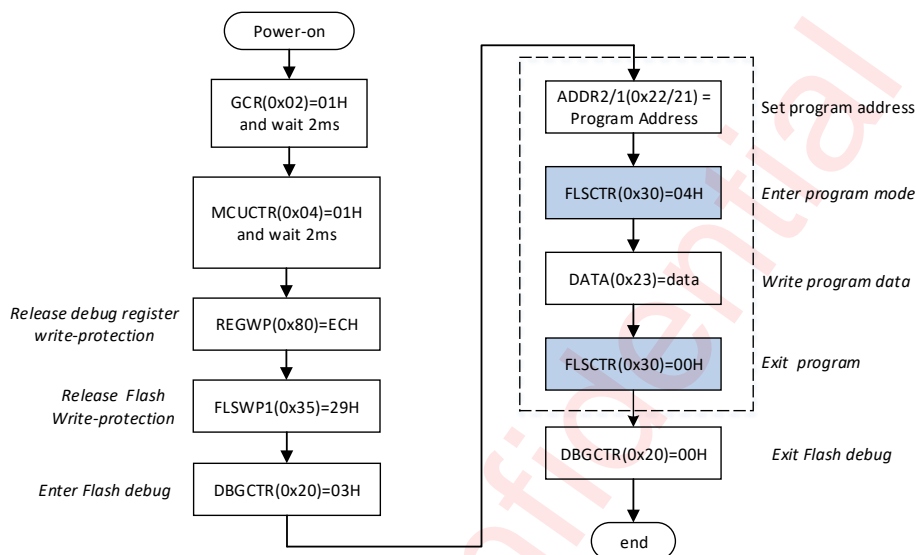

Figure 13 Single byte programming through 100k/400kHz I²C interface

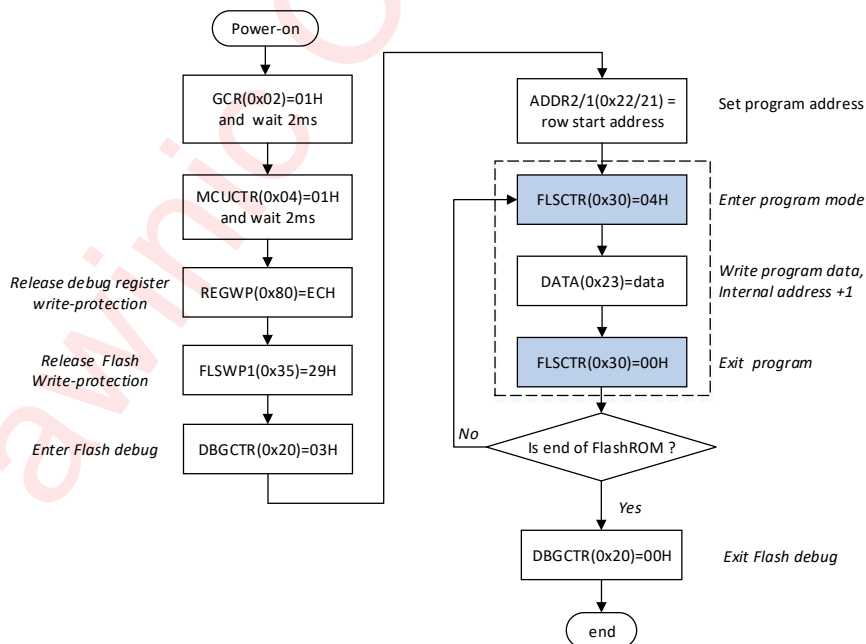

Figure 14 Continuous single-byte programming through 100kHz/400kHz I²C interface

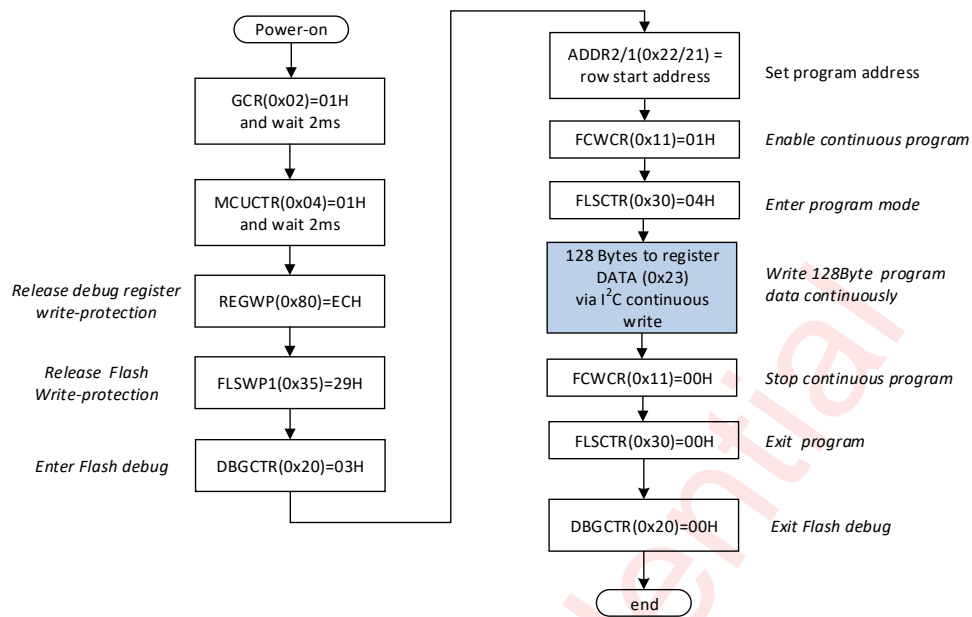

Figure 15 Sequential 128-bytes programming through 400kHz I²C interface

Note:

Due to the strict timing requirements of Flash ROM operation, incorrect operation may results in flash data errors. For detailed firmware programming guide, please contact AWINIC's FAE or refer to document: "Application note: AW22127B/AW22118 FlashROM Program Guide".

REGISTER DESCRIPTION

REGISTER LIST

Addr.	Name	W/R	Function description
00H	IDR	R	Device ID register
01H	SRSTR	R/W	Software reset control register
02H	GCR	R/W	Global control register
03H	CLKCFG	R/W	clock configuration register
04H	MCTR	R/W	MCU control register
05H	TASK0	R/W	MCU Task setting register 0
06H	TASK1	R/W	MCU Task setting register 1
07H	PST	R	MCU program status register
08H	ICR	R/W	Interrupt configuration register
09H	IER	R/W	Interrupt enable register
0AH	ISR	R	Interrupt status register
0BH	IMAX	R/W	Global max output current for all LED pin
0CH	AUDCTR	R/W	Audio path control register
0DH	PIGR	R/W	PGA initial gain setting register
0EH	PRGR	R	PGA real time gain register
0FH	UVCR	R/W	UVLO detection configuration register
10H	UVTHR	R/W	UVLO detection threshold register

REGISTER BIT MAP

Addr	Name	W/R	Bit7	Bit 6	Bit 5	Bit 4	Bit 3	Bit 2	Bit 1	Bit 0
00H	IDR	RO	0	0	1	0	0	1	1	1
01H	SRSTR	R/W	D7	D6	D5	D4	D3	D2	D1	D0
02H	GCR	R/W	ADPDD	ENPDD	OTMD	OTPD	UVME	UVLOE	OSCDIS	CHIPEN
03H	CLKCR	R/W	LOCS	LOCPD	CLKSEL		FREQ			
04H	MCTR	R/W	-	-	-	-	-	MWE	MRST	ME
05H	TASK0	R/W	TASK0							
06H	TASK1	R/W	TASK1							
07H	PST	RO	PST							
08H	ICR	R/W	INTWTH							INTMD
09H	IER	R/W	LIE	UIE	OIE	WDIE	SIE3	SIE2	SIE1	SIE0
0AH	ISR	RO	LIS	UIS	OIS	WDIS	SIS3	SIS2	SIS1	SIS0
0BH	IMAX	R/W	-	-	-	-	IMAX			
0CH	AUDCTR	R/W	-	-	-	-	PRCHG	PGABP	AGCE	AUDE
0DH	PIGR	R/W	IGAIN							
0EH	PRGR	R	RGAIN							
0FH	UVCR	R/W	-	-	DEGTIM					
10H	UVTHR	R/W	-	-	-	-	-	UVTH		

DETAILED REGISTER DESCRIPTION

IDR, Chip ID Register

Address: 0x00, RO, default: 0x27

7	6	5	4	3	2	1	0
D7	D6	D5	D4	D3	D2	D1	D0

Bit	Symbol	Description
7:0	IDR	Chip ID, read out is 0x27 for AW22127B

SRSTR, Software Reset Register

Address: 0x01, R/W, default: 0x76

7	6	5	4	3	2	1	0
D7	D6	D5	D4	D3	D2	D1	D0

Bit	Symbol	Description
7:0	IDR	Writing 0x55 to this register will cause reset for this device, including internal logic and configuration register. Read out value is always 0x76

GCR, Global Control Register

Address: 0x02, R/W, default: 0x00

7	6	5	4	3	2	1	0
ADPDD	ENPDD	OTMD	OTPD	UVME	UVLOE	OSCDIS	CHIPEN

Bit	Symbol	Description
7	ADPDD	Disable internal pulled down resistor of pin AD 0: enable pulled-down resistor (default) 1: disable pulled-down resistor
6	ENPDD	Disable internal pulled down resistor of pin EN 0: enable pulled-down resistor (default) 1: disable pulled-down resistor
5	OTMD	Over Temperature monitor disable 0: OT monitor enabled (default) 1: OT monitor disabled.
4	OTPD	Over Temperature Protection disable control 0: enable OTP, clear CHIPEN bit when over-temperature condition is met (default) 1: disable OTP
3	UVME	UVLO monitor enable 0: enable UVLO monitor (default) 1: disable UVLO monitor
2	UVLOE	UVLO protect enable 0: enable UVLO protection (default) 1: disable UVLO protection, clear CHIPEN when UVLO fault is detected.
1	OSCDIS	Internal OSC disable control. 0: enable (default) 1: disable
0	CHIPEN	Device operating Enable

0: Disable, the device is in standby state, only I²C interface is active to keep low power state. **(default)**
1: Enable, the device enters active state

CLKCR, Clock Configuration Register

Address: 0x03, W/R, default: 0x00

7	6	5	4	3	2	1	0
LOCS	LOCPD	CLKSEL		FREQ			

Bit	Symbol	Description
7	LOCS	Read only. Loss of Clock status on pin SYNC. LOC detection is only useful in the case of clock being provided from pin SYNC. 0: clock input exist 1: Loss of Clock Input is detected
6	LOCPD	Disable protection when external input clock loss is detected 0: Enable protection. LED output close when loss of external clock input 1: Disable protection.
5:4	CLKSEL	Internal Clock Source Selection and Output Control 00: use internal OSC, and pin SYNC output hi-Z 01: use internal OSC and output it to pin SYNC 1x: use external input clock from of pin SYNC
3:0	FREQ	Internal master clock frequency setting 0: 24.576MHz (default) 4: 4.096MHz 1: 12.288 MHz 5: 2.048MHz 2: 8.192 MHz 6: 1.024MHz 3: 6.144MHz 7: 12.288MHz

MCTR, MCU Control Register

Address: 0x04, W/R, default: 0x00

7	6	5	4	3	2	1	0
-	-	-	-	-	MWE	MRST	ME

Bit	Symbol	Description
2	MWE	MCU Wake Up Enable 0: No operation (default) 1: Send external to internal MCU to resume program execution
1	MRST	MCU Reset control 0: MCU reset (default) 1: MCU no reset
0	ME	MCU Work Enable 0: MCU disabled, no clock send to internal MCU 1: MCU enabled

TASK0, Task Register0

Address: 0x05, R/W, default: 0x00

7	6	5	4	3	2	1	0
---	---	---	---	---	---	---	---

TASK0							
-------	--	--	--	--	--	--	--

Bit	Symbol	Description
7:0	TASK0	MCU Task Code 0. Internal MCU can read this register to decide which function to execute. Before MCU operates, user should configure this register first, and then start up MCU.

TASK1, Task Register1

Address: 0x06, R/W, default: 0x00

7	6	5	4	3	2	1	0
TASK1							

Bit	Symbol	Description
7:0	TASK1	MCU Task Code 1, Its function is similar to register TASK0.

PST, MCU Program Execution Status Register

Address: 0x07, RO, default: 0x00

7	6	5	4	3	2	1	0
PST							

Bit	Symbol	Description
7:0	PST	Program Execution Status Code, which is written by internal MCU. 0x00: No program is executing 0x01: Sleep 0x02: IDLE 0x10: Breathe Lighting mode is running 0x11: Breathe Lighting has finished 0x20: Audio sync. Mode is running 0x21: Audio sync. Mode has finished.

ICR, Interrupt Configuration Register

Address: 0x08, R/W, default: 0x00

7	6	5	4	3	2	1	0
INTWTH							INTMD

Bit	Symbol	Description
7:1	INTWTH	Pulse Width Setting, only used in pulse interrupt mode (INTMD=1) Width = INTWTH + 1 (μs)
0	INTMD	Interrupt Output Mode Selection 0: Level mode, pin INTN output low when interrupt occurs 1: Pulse mode, pin INTN output negative pulse when interrupt occurs

IER, Interrupt Enable Register

Address: 0x09, R/W, default: 0x00

7	6	5	4	3	2	1	0
LIE	UIE	OIE	WDIE	SIE3	SIE2	SIE1	SIE0

Bit	Symbol	Description
7	LIE	Loss of Clock (LOC) Fault Interrupt Enable 0: Disable (default) 1: Enable
6	UIE	UVLO Fault Interrupt Enable 0: Disable (default) 1: Enable
5	OIE	Over Temperature Fault Interrupt Enable 0: Disable (default) 1: Enable
4	WDIE	Watch Dog Fault Interrupt Enable. 0: Disable (default) 1: Enable
3	SIE3	Firmware Version Detect Error Interrupt Enable 0: Disable (default) 1: Enable
2	SIE2	Flash-ROM Correction Failure Interrupt Enable 0: Disable (default) 1: Enable
1	SIE1	MCU Check Failure Interrupt Enable 0: Disable (default) 1: Enable
0	SIE0	Functional Program Complete Interrupt Enable 0: Disable (default) 1: Enable

ISR, Interrupt Status Register

Address: 0x0A, RO, default: 0x00

7	6	5	4	3	2	1	0
LIS	UIS	OIS	WDIS	SIS3	SIS2	SIS1	SIS0

Bit	Symbol	Description
7	LIS	Loss of Clock (LOC) Fault Interrupt Status 0: No interrupt 1: Interrupt
6	UIS	UVLO Fault Interrupt Status 0: No interrupt 1: Interrupt
5	OIS	Over Temperature Fault Interrupt Status 0: No interrupt 1: Interrupt

4	WDIS	Watch Dog Fault Interrupt Status. 0: No interrupt 1: Interrupt
3	SIS3	Firmware Version Detect Error Interrupt Status 0: No interrupt 1: Interrupt
2	SIS2	Flash-ROM Correction Failure Interrupt Status 0: No interrupt 1: Interrupt
1	SIS1	MCU Check Failure Interrupt Status 0: No interrupt 1: Interrupt
0	SIS0	Functional Program Complete Interrupt Status 0: No interrupt 1: Interrupt

IMAX, LED Max Current Configuration Register

Address: 0x0B, R/W, default: 0x00

7	6	5	4	3	2	1	0
-	-	-	-	IMAX			

Bit	Symbol	Description
7:4	-	Reserved, should be kept as 0000.
3:0	IMAX	Max Constant Current Configuration for pin LED1~LED9 0000: 3mA 1000: 2mA 0001: 6mA 1001: 4mA 0010: 9mA 1010: 6mA 0011: 15mA 1011: 10mA 0100: 30mA 1100: 20mA 0101: 45mA 1101: 30mA 0110: 60mA 1110: 40mA 0111: 75mA 1111: 50mA

AUDCTR, Audio Path Control Register

Address: 0x0C, R/W, default:0x00

7	6	5	4	3	2	1	0
-	-	-	-	PRCHG	PGABP	AGCE	AUDE

Bit	Symbol	Description
7:4	-	Reserved
3	PRCHG	ADC Pre-charge Enable 0: Disable (default) 1: Enable
2	PGABP	PGA Bypass Control, only used in test. 0: ADC source from PGA (default) 1: ADC source from pin AUD directly

1	AGCE	AGC enable 0: Disable (default) 1: Enable
0	AUDE	Audio Synchronization Function Enable 0: Disable, reset all audio process relative module 1: Enable

PIGR, PGA Initial Gain Configuration Register

Address: 0x0D, R/W, default: 0x00

7	6	5	4	3	2	1	0
-	-	IGAIN					

Bit	Symbol	Description
7:6	-	non-defined
5:0	IGAIN	PGA Initial Gain Setting. PGA Gain = IGAIN -12dB 000000: -12 dB 000001: -11 dB 001100: 0 dB 001101: +1 dB 111111: +51dB

PRGR, PGA Real Gain Register

Address: 0x0E, RO, default: 0x00

7	6	5	4	3	2	1	0
-	-	RGAIN					

Bit	Symbol	Description
7:6	-	non-defined
5:0	RGAIN	PGA Real Gain. Real gain of PGA is adjusted by internal MCU according to audio signal from pin AUD.

UVCR, UVLO Detection Configuration Register

Address: 0x0F, R/W, default: 0x0F

7	6	5	4	3	2	1	0
-	-	DEGTIM					

Bit	Symbol	Description
5:0	DEGTIM	Ultra-Low Voltage Lock (UVLO) Detection De-bounce Time Setting. De-bounce time = DEGTIM *16 μ s

UVTHR, UVLO Detection Threshold Register

Address: 0x10, R/W, default: 0x03

7	6	5	4	3	2	1	0
-	-	-	-	-	UVTH		

Bit	Symbol	Description
2:0	UVTH	UVLO Detection Voltage Threshold. 000: 1.9v 001: 2.0v 010: 2.1v 011: 2.2v (default) 100: 2.3v 101: 2.4v 110: 2.5v 111: 2.6v

awinic Confidential

TAPE AND REEL INFORMATION

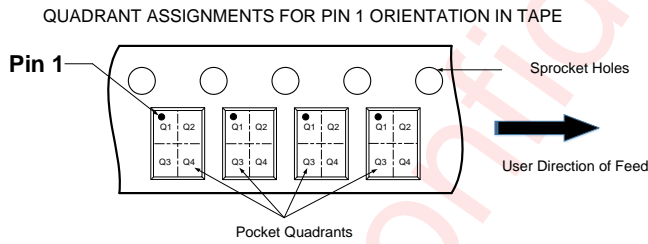
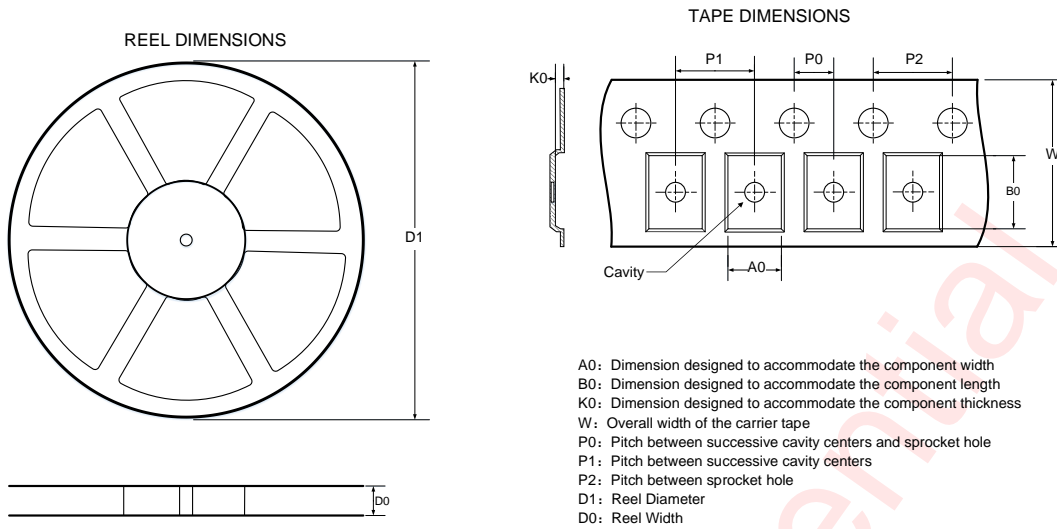

Note: The above picture is for reference only. Please refer to the value in the table below for the actual size

DIMENSIONS AND PIN1 ORIENTATION

D1 (mm)	D0 (mm)	A0 (mm)	B0 (mm)	K0 (mm)	P0 (mm)	P1 (mm)	P2 (mm)	W (mm)	Pin1 Quadrant
330	12.4	2.14	2.72	0.84	2.00	8.00	4.00	12.00	Q1

All dimensions are nominal

PACKAGE DESCRIPTION

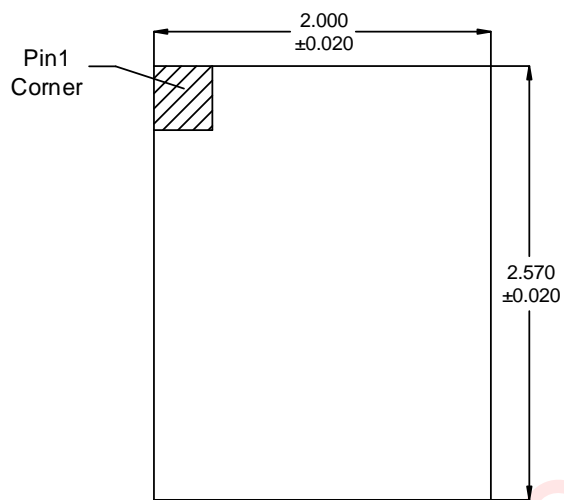

Top View

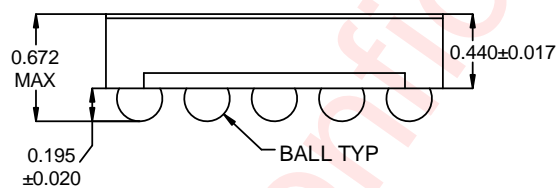

Side View

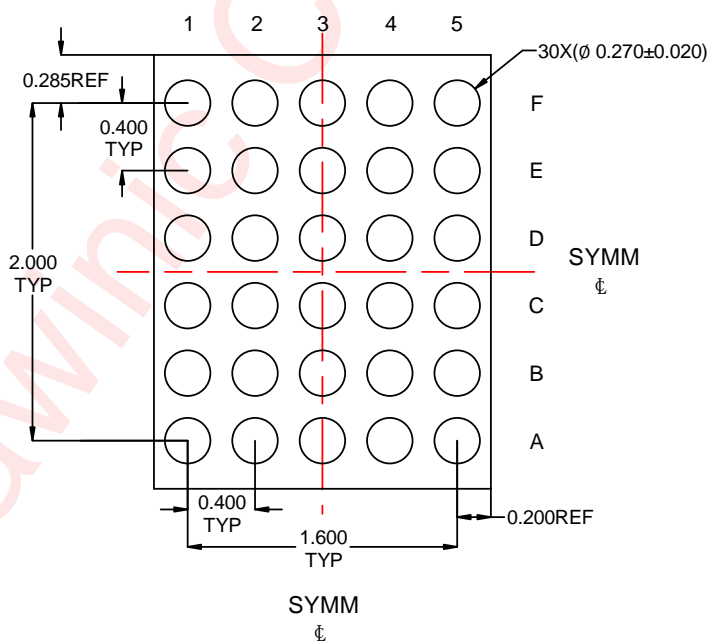

Bottom View

Unit: mm

LAND PATTERN DATA

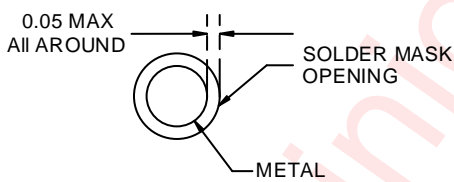
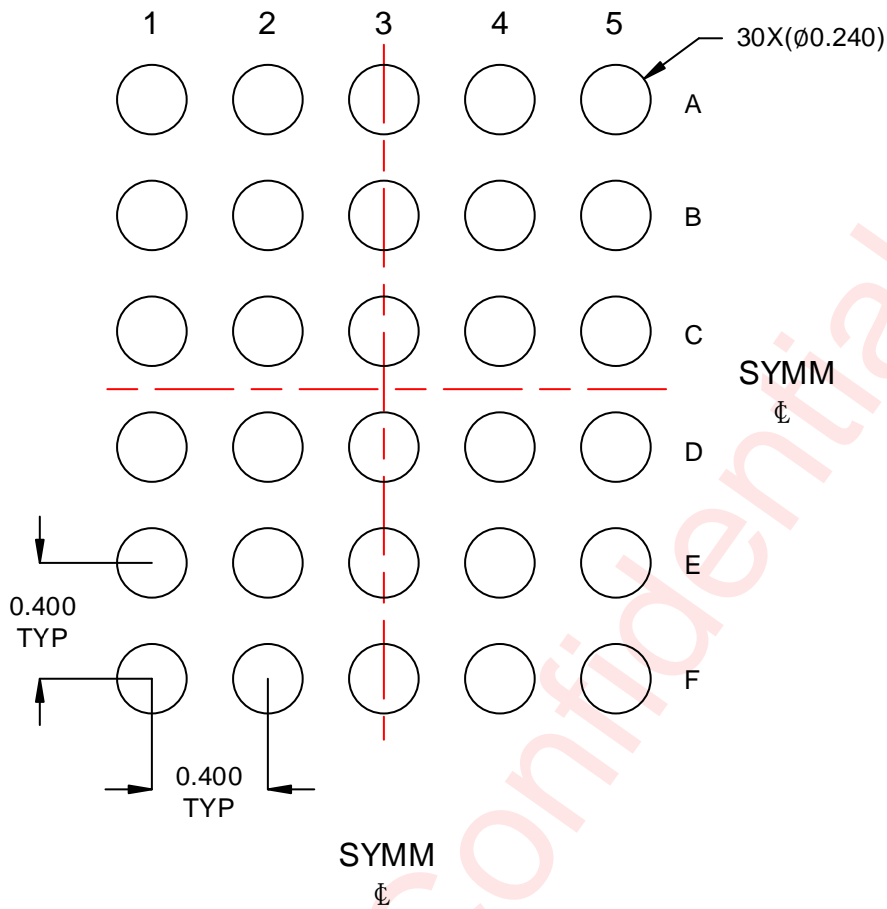

NON-SOLDER MASK DEFINED

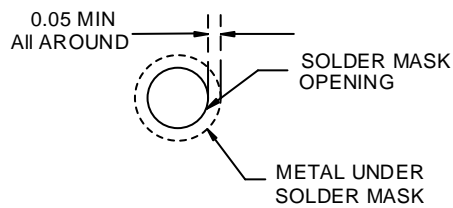

SOLDER MASK DEFINED

Unit: mm

REFLOW

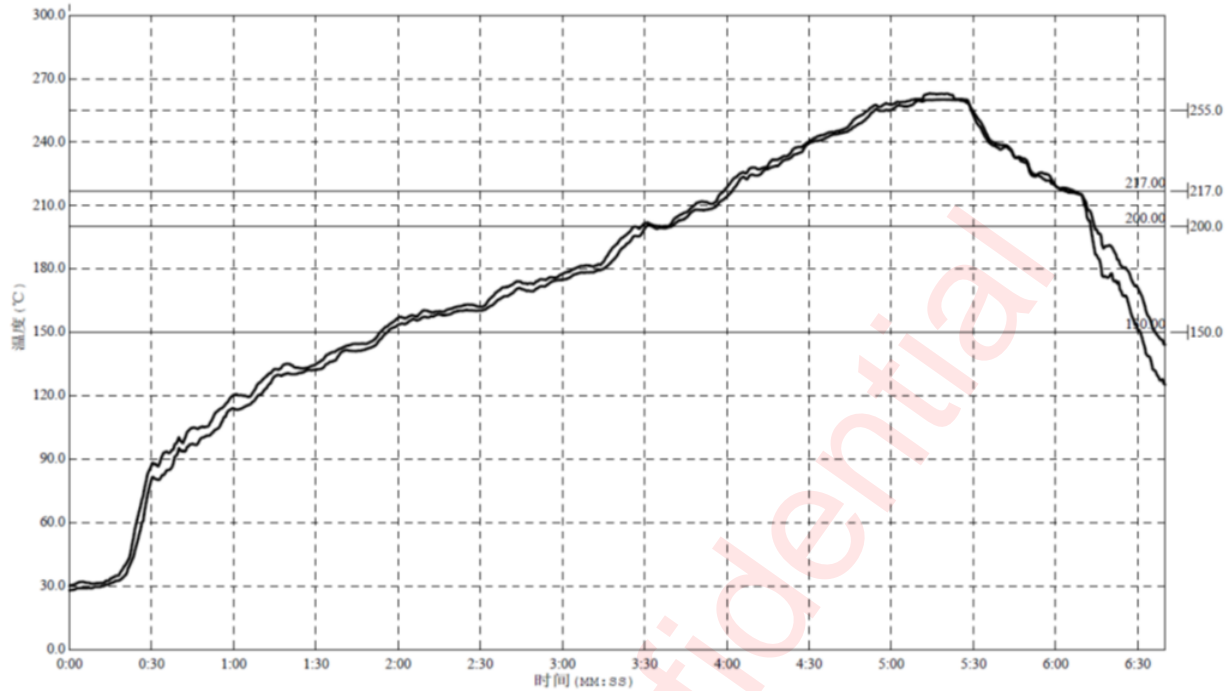

Reflow Note	Spec
Average ramp-up rate (217°C to peak)	Max. 3°C /sec
Time of Preheat temp. (from 150°C to 200°C)	60-120sec
Time to be maintained above 217°C	60-150sec
Peak Temperature	>260°C
Time within 5°C of actual peak temp	20-40sec
Ramp-down rate	Max. 6°C /sec
Time from 25°C to peak temp	Max. 8min

NOTE 1: All data are compared with the package-top temperature, measured on the package surface;

NOTE 2: AW22127B adopted the Pb-Free assembly.

REVISION HISTORY

Version	Date	Change Record
V1.0	Jan. 2021	Initial Version
V1.1	Jan. 2022	Correct the description of chip-id ---page19
V1.2	Feb. 2022	Update the value of chip-id ---page19
V1.3	Apr.2022	Modify the application of figure4 ---page4

awinic Confidential

DISCLAIMER

All the trademarks mentioned in the document are the property of their owners.

Information in this document is believed to be accurate and reliable. However, Shanghai AWINIC Technology Co., Ltd (AWINIC Technology) does not give any representations or warranties, expressed or implied, as to the accuracy or completeness of such information and shall have no liability for the consequences of use of such information.

AWINIC Technology reserves the right to make changes to information published in this document, including without limitation specifications and product descriptions, at any time and without notice. Customers shall obtain the latest relevant information before placing orders and shall verify that such information is current and complete. This document supersedes and replaces all information supplied prior to the publication hereof.

AWINIC Technology products are not designed, authorized or warranted to be suitable for use in medical, military, aircraft, space or life support equipment, nor in applications where failure or malfunction of an AWINIC Technology product can reasonably be expected to result in personal injury, death or severe property or environmental damage. AWINIC Technology accepts no liability for inclusion and/or use of AWINIC Technology products in such equipment or applications and therefore such inclusion and/or use is at the customer's own risk.

Applications that are described herein for any of these products are for illustrative purposes only. AWINIC Technology makes no representation or warranty that such applications will be suitable for the specified use without further testing or modification.

All products are sold subject to the general terms and conditions of commercial sale supplied at the time of order acknowledgement.

Nothing in this document may be interpreted or construed as an offer to sell products that is open for acceptance or the grant, conveyance or implication of any license under any copyrights, patents or other industrial or intellectual property rights.

Reproduction of AWINIC information in AWINIC data books or data sheets is permissible only if reproduction is without alteration and is accompanied by all associated warranties, conditions, limitations, and notices. AWINIC is not responsible or liable for such altered documentation. Information of third parties may be subject to additional restrictions.

Resale of AWINIC components or services with statements different from or beyond the parameters stated by AWINIC for that component or service voids all express and any implied warranties for the associated AWINIC component or service and is an unfair and deceptive business practice. AWINIC is not responsible or liable for any such statements.