

东莞市高钺达电子科技有限公司

DONGGUAN GAOYUEDA ELECTRONICS CO., LTD

承 认 书

SPECIFICATION FOR APPROVAL

Customer : _____

Description : 编码器全码有感

Part No. : BMQ11-N1A1-2012-A

Customer P/N : _____

东莞市高钺达电子科技有限公司		客 户	
工程 承 认 章		工程 承 认 章	
品 管 承 认 章		品 管 承 认 章	

TAIWAN FACTORY: 協昌精密工業股份有限公司
 ADD: NO. 95 Twopart Southharbour road, Taipei, Taiwan. CHINA
 地址: 中国臺灣台北市南港路二段 95 號
 TEL: 02-27884666 FAX: 02-26535492
<http://www.twshetime.com>
 CHINA FACTORY: 东莞市高钺达电子科技有限公司
 地址: 东莞市虎门镇路东长元一路 2 号
 TEL: 0769-85108085 FAX: 0769-6891569
 E-mail: szgaosuda@163.com

REV.	DESCRIPTION	APPD	DATE

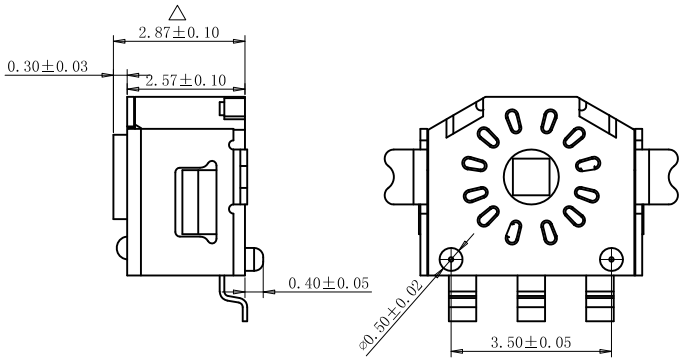
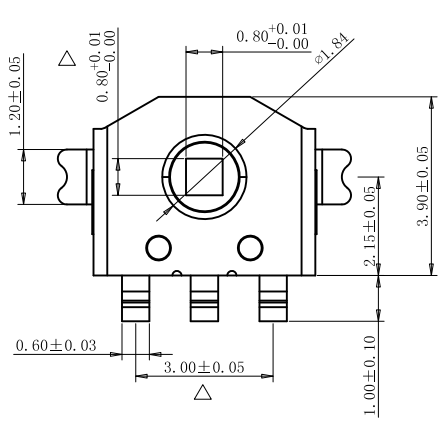

技术规格:
 1 材料
 主体 PA46
 转子 PA46
 端子 铜合金电镀银
 弹片 铜合金
 卡钩 不锈钢
 外壳 铜合金电镀锡
 2 使用条件
 温度 -40° C +80° C
 电流 DC 5V 500mA
 寿命 100000 转

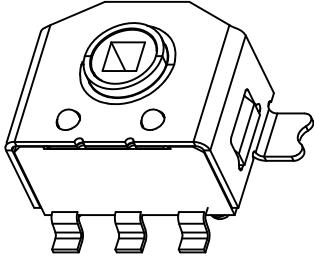
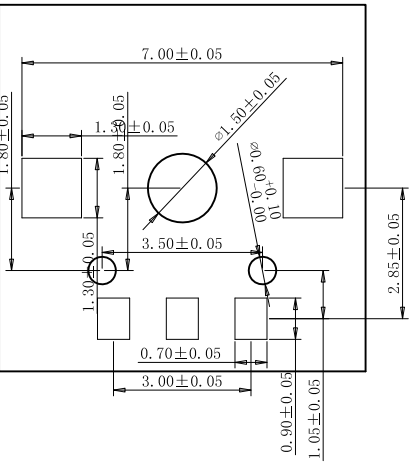
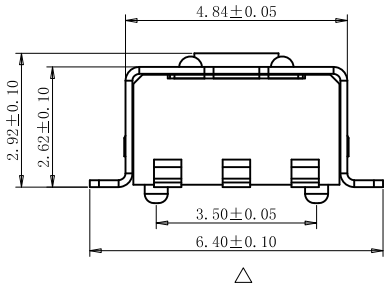

CW ROTATION

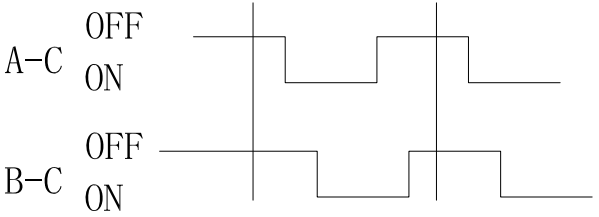

12 pulse 12 click

PART NO: BMQ11-N1A1-2012-A		MATERIAL:		东莞市高钺达电子科技有限公司		
LOT NO:		FINISH:				
UNIT: MM	SIZE: A4	COLOR:		TITLE: 全码编码器		
TOLERANCES: X. X=±0.35 X. XX=±0.25 X. XXX=±0.15		GENERAL ANGLE: X. X=±3.0° X. XX=±2.0°		DR: 刘静	DWG NO: FP-090012	
				CHK: 刘静		REV: A
				APP: 刘静		SCALE: 1:1
				SHEET: 1 OF 1		

REV.	DESCRIPTION	APPD	DATE

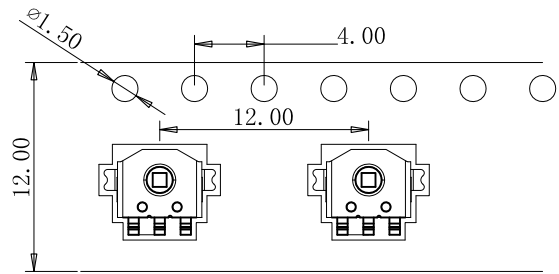

<TABLE 1> PACKAGING QUANTITY

QTY/REEL	REEL/CARTON	QTY/CARTON
1500	10	15000

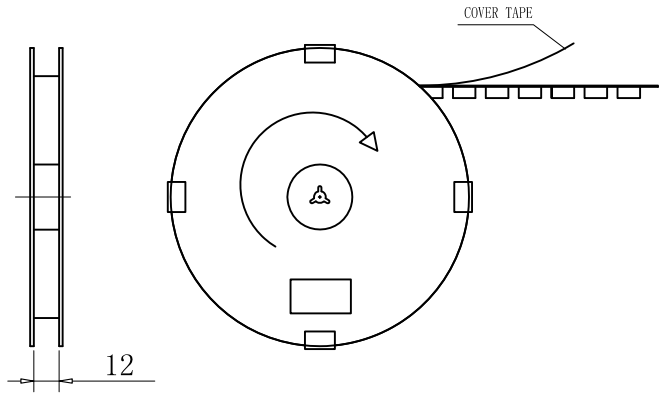
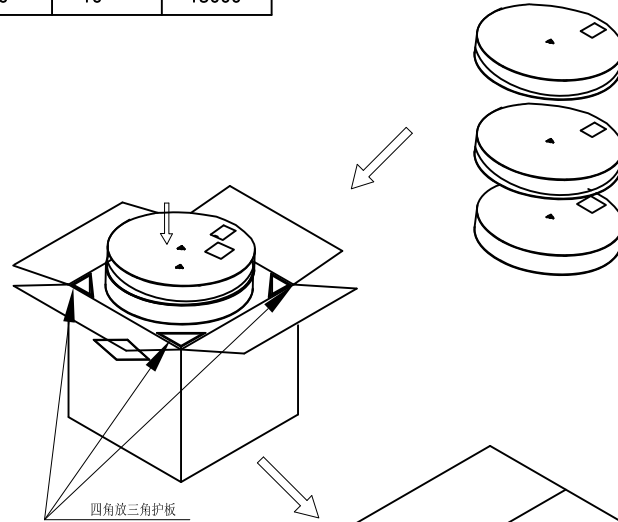
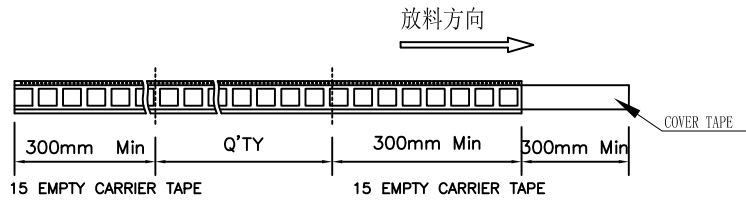

- 包装明细:
- 1, 每盘前后空5PSC, 中间包装1500PCS.
 - 2, 入库时每20盘用大袋子套住抽真空.
 - 2, 待出货时, 根据客户订单, 每盘取出单独套袋子抽真空.
 - 3, 纸箱四角放脚柱.

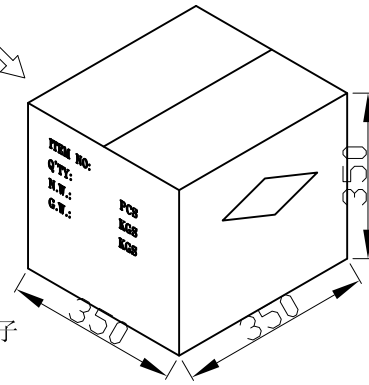

PART NO:		MATERIAL:		东莞市高钺达电子科技有限公司	
LOT NO:		FINSH:			
UNIT: MM	SIZE: A4	COLOR:		TITLE: 编码器 包装图	
TOLERANCES: X. X=±0.35 X. XX=±0.25 X. XXX=±0.15		GENERAL ANGLE: X. X=±3.0° X. XX=±2.0°		DR: 刘静	
APP:		CHK:		DWG NO: FP-090012	
SCALE: 1:1		SHEET: 1 OF 1		REV: A	

东莞市高钺达电子科技有限公司

产品性能规范

产品名称

产品料号

1. General Characteristics 常规特性:

- 1.1 Application: This specification is applied to rotary encoder used for general.
适用范围: 该承认书适用于常规旋转编码器。
- 1.2 Operating Temperature Range: -20°C to $+85^{\circ}\text{C}$
使用温度范围: -20°C 到 $+85^{\circ}\text{C}$
- 1.3 Operating Relative Humidity: $\leq 80\%$ RH
使用相对湿度: $\leq 80\%$ RH
- 1.4 Test Conditions: Unless otherwise specified, the atmospheric conditions for making measurements and tests are as follows:
试验条件: 除非另有规定, 进行测量和试验的大气条件如下:
Environment Temperature : $5-35^{\circ}\text{C}$
环境温度: $5-35^{\circ}\text{C}$
Relative Humidity: 45-85%
相对湿度: 45-85%
Atmospheric Pressure: 85-105Kpa
大气压力: 85-105Kpa

2. Appearance, Structure and Dimensions 外观、结构和尺寸:

- 2.1 Appearance: The encoder shall have good finishing, and no rust, crack or plating defects.
外观: 产品外观良好, 无锈蚀、裂纹和电镀缺陷。
- 2.2 Structure & Dimensions: See Product Specifications.
结构及尺寸: 参见产品图
- 2.3 Markings: See Product Specifications.
表示: 参见产品图

3. Ratings 额定负载: 5VDC 0.5mA

4. Electrical Characteristics 电气特性

No	item 项目	Criteria 标准	Test Method 试验方法
4.1	Contact Resistance 接触电阻	200m Ω Max 初始值 initial value	Using the micro resistance tester with error less than 5% for testing 使用误差小于5%的微电阻测试仪进行测试。
4.2	insulation resistance 绝缘阻抗	50 M Ω Min	Using the insulation resistance tester, setting parameters to DC50V. The insulation resistance between the terminal and the cover, the terminal and 使用绝缘电阻测试仪, 设置为DC50V, 测试端子与外壳, 端子与端子间绝缘阻抗。
4.3	Dielectric Voltage 耐压	AC50V test 60s No dielectric break down occur AC50V 测试60s 无击穿发生	Using the voltage resistance tester, set the parameters to the AC50V, test the voltage resistance between the terminal and cover or terminal and terminal, time is 60s 使用耐压测试仪, 设置为AC50V, 测试端子与外壳, 端子与端子间耐压值, 时间60秒

东莞市高钺达电子科技有限公司

产品性能规范		产品名称			
		产品料号			
No	item 项目	Criteria 标准		Test Method 试验方法	
4.4	Output signal format 输出信号	$T1, T2 \geq 4mS$		<p>The encoder rotates 360 degrees per second, 2 Phase-different signals (signalA, signalB) Derails shown in (The broken line shows detent position.) 编码器每秒转动360度, A B相输出波形图如下图所</p> <div style="display: flex; justify-content: space-around;"> <div style="text-align: center;"> <p>CW ROTATION</p> <p>12 pulse 12 click</p> </div> <div style="text-align: center;"> <p>CCW ROTATION</p> <p>12 pulse 12 click</p> </div> </div>	
		Shaft rotational direction 转动方向	端子信号		
		C. W 正转	AC		
			BC		
	C. C. W 反转	B-C			
		A-C			
4.5	Switching characteristics 旋转噪声	Chattering 抖动 $T1 \leq 1mS$		<p>The encoder is connected to the circuit in Figure 1. The encoder rotates 360 degrees per second. When the circuit is switched from ON to OFF, At 2.5v voltage, test circuit generates vibration time, when every times. 将编码器连接在下图所示的电路上, 用示波器观察编码器旋转一整圈的波形, 在电压2.5V时, 测试电路毛刺噪声</p> <div style="display: flex; justify-content: space-around;"> <div style="text-align: center;"> </div> <div style="text-align: center;"> </div> </div>	

东莞市高钺达电子科技有限公司

产品性能规范	产品名称	
	产品料号	

5. Mechanical Characteristics 机械特性

No	item 项目	Criteria 标准	Test Method 试验方法
5.1	Detent points 驻位间隔	12 detent points each detent angle:30° ±5 12个驻位 每个驻位间隔30° ±5	
5.2	Output waves 输出脉冲数量	12pulse/360° 12脉冲/360°	Oscilloscope test available 用示波器观察
5.3	Rotational force 旋转力矩	10±5gf.cm	Use of torsion gauges ,The test head is inserted into the rotating shaft , rotates according to the rotation direction of the shaft, and the experiment is carried out with the uniform rotation force 使用扭力计, 将旋转杆插入编码器中, 沿旋转轴均匀转动, 读取最大值
5.4	Terminal Strength 端子强度	Shall be free from terminal looseness, damage and insulator breakage.The electrical performance requirements specified shall be satisfied. 端子无松动, 损坏, 以及电镀层	A static load of 1N shall be applied to the tip of terminals for 10s in any direction. 使用拉力计, 在端子部位拉扯, 持续时间10秒
5.5	Vibration Proof 震动测试	After test, Contact resistance:5Q Max. Insulation resistance:10MQ Min. The electrical performance requirements specified shall be satisfied. No abnormalities shall be recognized in appearance and construction. 震动测试后: 接触阻抗: 5Ω MAX 绝缘阻抗: 10MΩ MIN 电气性能符合要求 表面及产品结构未见损坏	Encoder shall be secured to a testing machine by a normal mounting device and method. Encoder shall be tested according to the following request:: (1)Vibration frequency range = 10~55 Hz (2)Total amplitude =1.5mm (3)Sweep ratio:10~55~10Hz Approx. 1 min (4)Method of changing the sweep vibration frequency: linear (5)Direction of vibration:Three perpendicular directions including actuating direction. (6)Duration:2 hours(6 hours in total) 将编码器固定在振动测试机上, 并使用以下条件进行测试。 1 振动频率 10-55Hz 2 增幅 1.5mm 3 频率变化10-55-10Hz 各持续一分钟 4 变频方法 线性变频 5 震动方向 三个相互垂直的方向 6 时间 每个方向2小时

东莞市高钺达电子科技有限公司

产品性能规范	产品名称	
	产品料号	

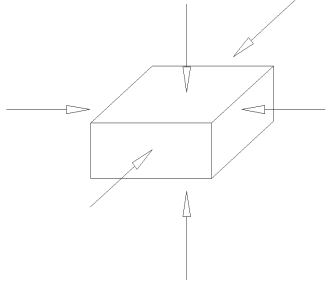
No	item 项目	Criteria 标准	Test Method 试验方法
5.6	Mechanical Shock 耐冲击	After test, Contact resistance:5Ω Max. Insulation resistance:10MΩ Min. The electrical performance requirements specified shall be satisfied. No abnormalities shall be recognized in appearance and construction. 震动测试后: 接触阻抗: 5Ω MAX 绝缘阻抗: 10MΩ MIN 电气性能符合要求 表面及产品结构未见损坏	Encoder shall be tested according to the following request: (1)Mounting Method: Normal (2)Acceleration: 490m/s ² (50G) (3)Duration: 11ms (4)Test Direction:6 directions <div style="text-align: center;">  </div> (5)Number of shocks:3 times per direction(18 times in total) 将编码器放在冲击力测试机上用以下条件测试: 1 安装方法 平躺安装 2 加速度 490m/s ² (50G) 3 加速时间 11 ms 4 冲击方向 如图所示六方向 5 冲击次数 每个方向三次 (总共18次)
5.7	按键压力	230g ±50g	将压入杆对准产品中间压入，待压入力达到最高点， 读取压力值

6. Soldering Characteristics 焊接性能

No	item 项目	Criteria 标准	Test Method 试验方法
6.1	Solder Ability 可焊性	Melting surface area should exceed 95% of the total 上锡面积不低于95%	The crucible is tested under the following parameters: (1)solder:tin paste containing more than 3% silver. (2)Welding teperature :245°Cmin. ; (3)Welding time :3 s min. 编码器在以下条件下进行粘锡试验 1 锡条 含银3%以上锡条 2 锡炉温度 240℃ 以上 3 粘锡时间 3秒以上

东莞市高钺达电子科技有限公司

产品性能规范	产品名称	
	产品料号	

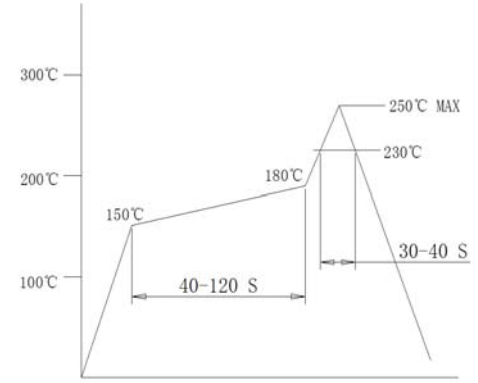
No	item 项目	Criteria 标准	Test Method 试验方法
6.2	Solder Heat Resistance 耐焊温度	No abnormalities shall be observed in appearance and operation. 无外观、塑胶变形不良，扭力衰减不大于10%，电气性能符合第4项	The filter is tested under the following parameters: e of welding:SMT 230 °C 30-40 S 250 °C 3-5 S 编码器SMT 焊接温度曲线如下图所示 1 230度以下 30-40秒 2 250±5度 3-5秒 

7. Durability characteristics 耐久测试

No	item 项目	Criteria 标准	Test Method 试验方法
7.1	Mechanical Life 机械寿命	After test Contact resistance:5Ω Max. Insulation resistance:10MΩ Min. The decay of the operating force should be within + 50% The electrical performance requirements specified in item 4.3-4.5 shall be satisfied. 测试后 接触阻抗: 5Ω MAX 绝缘阻抗: 10MΩ MIN 扭矩降低: 50% MAX	Under the condition of no load, the speed is 30 times per minute, and the life test equipment is continuously converted on the life test equipment. the working mode of the life test equipment is to rotate 360 degrees counterclockwise immediately after rotating 360 degrees clockwise for the test once 在不带负载的情况下，在寿命测试机上连续旋转，寿命测试机速度为每分钟30圈，旋转方式为正转一圈反转一圈交替进行

东莞市高钺达电子科技有限公司

产品性能规范	产品名称	
	产品料号	

No	item 项目	Criteria 标准	Test Method 试验方法
7.2	Electronics Life 电气寿命	After the experiment: Contact resistance:5Ω Max. Electrical resistance :10 MΩ Min. No pulse number increases or decreases badly The telecommunication performance shall meet the requirements of Sections 4.4 and 4.5 测试后 接触阻抗: 5Ω MAX 绝缘阻抗: 10MΩ MIN 无脉冲增加或缺少	Under the condition of the following load, the speed is 30 times/ min, and the life test equipment is continuously converted on the life test equipment. The working mode of the life test equipment is to rotate 360 degrees counterclockwise immediately after the clockwise rotation 360 degrees for the test once..Load:0.1 mA 5VDC 在带以下负载的情况下, 在寿命测试机上连续旋转, 寿命测试机速度为每分钟30圈, 旋转方式为正转一圈反转一圈交替进行 负载 0.1mA 5V DC

8. Weather Proof Characteristics 耐气候性

No	item 项目	Criteria 标准	Test Method 试验方法
8.1	Cold Proof 低温	After test, Contact resistance:5Ω Max. Insulation resistance:10M Ω Min. The Electrical performance requirements specified shall be satisfied. 测试后 接触阻抗: 5Ω MAX 绝缘阻抗: 10MΩ MIN	The test piece shall remain free for 240 hours in a temperature control box of -20 ±2°C, and then recover for 1 hour at normal temperature and humidity. The test piece shall be measured within 1 hour thereafter. The water droplets shall disappear 产品在-20±2°C的恒温箱内无工作状态静止存放240小时, 然后再常温常湿下恢复1小时, 并在此后1小时内进行测试, 测试时需去除露水。
8.2	Hot Proof 高温		The test piece is kept at 240hours without working pressure in the temperature control box of 80±2°C, then recovered at normal temperature and humidity for 1 hour, and measured within 1 hour after that, the water droplets should disappear. 产品在80±2°C的恒温箱内无工作状态静止存放240小时, 然后再常温常湿下恢复1小时, 并在此后1小时内进行测试
8.3	Moisture Resistance 恒温恒湿	After test, Contact resistance:5Ω Max. Insulation resistance:10M Ω Min. 测试后 接触阻抗: 5Ω MAX 绝缘阻抗: 10MΩ MIN	After testing at 40± 2° C, 90~95% RH for 240 hours, the encoder shall be allowed to stand under normal temperature and humidity conditions for 1 hour, and measurement shall be made within 1 hour after that. 产品在温度40±2°C 湿度90~95% RH的恒温恒湿箱内无工作状态静止存放240小时, 然后再常温常湿下恢复1小时, 并在此后1小时内进行测试

东莞市高钺达电子科技有限公司

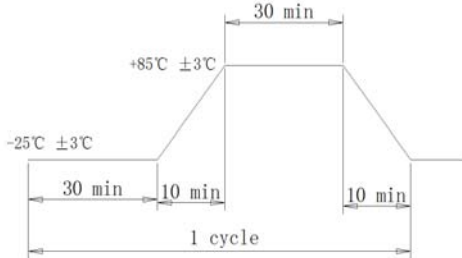
产品性能规范		产品名称	
		产品料号	
No	item 项目	Criteria 标准	Test Method 试验方法
8.4	Temperature Cycling 冷热冲击	After test, Contact resistance:5Ω Max. Insulation resistance:10MΩ Min. The electrical performance requirements specified in item 4.3-4.5 shall be satisfied. 测试后 接触阻抗: 5Ω MAX 绝缘阻抗: 10MΩ MIN 电气性能符合 4.3-4.5的要求	After 5 cycles of following conditions, the encoder shall be allowed to stand under normal temperature and humidity conditions for 1 hour, and measurement shall be made within 1 hour after that. Water drops shall be eliminated. 按以下条件进行冷热冲击测试五次, 然后在常温下恢复一小时, 并在后续一小时内进行测试, 应除去露水。 
8.5	Salt Mist 盐雾测试	After the test is dried, there are no corrosion spots on the metal parts that affect the performance of the product, and the electrical properties should meet the requirements of Article 4. 产品干燥后, 金属件表面没有影响产品性能的锈蚀点, 电器性能应符合第4项要求	The encoder shall be checked after the following test: (1) Temperature: 35± 2° C (2) Salt Solution: 5±1% (Solids by mass). (3) Salt deposit shall be removed by running water. (4) Duration: 48 hours 将产品放入盐雾测试机中, 条件如下 1 温度 35± 2° C 2 盐溶液浓度 5±1% 3 产品表面不可有积液 4 时间 48小时
8.6	Vulcanization test 金属硫化测试	After the test is dried, there are no corrosion spots on the metal parts that affect the performance of the product, and the electrical properties should meet the requirements of Article 4. 产品干燥后, 金属件表面没有影响产品性能的锈蚀点, 电器性能应符合第4项要求	The specimens were tested under the following conditions: (1) Temperature : 35±2° C (2) Potassium sulfide solution concentration 2% (mass percentage). Time : 2 minutes 按如下条件进行硫化测试 1 温度 35±2° C 2 硫化钾溶液浓度 2% (质量百分比) 3 时间 2分钟

东莞市高钺达电子科技有限公司

产品性能规范

产品名称

产品料号

9. Management of environmental hazardous substances 环境有害物质管理

This product complies with the "√" hook under the environmental hazardous substances management standard selection.

在下方符合的环境要求标准下打"√"

√ 本产品符合欧盟ROHS 2.0标准要求.

√ 本产品符合欧盟HF标准要求.

√ 本产品符合欧盟REACH标准要求.

10. Storage condition 储存条件

10.1 In order to protect the switch performance and the soldering conditions, it should keep the switch under the following conditions:

为了防止本产品的功能受影响, 请按以下条件储存

10.1.1. Temperature of -30°C to +80°C, with humidity lower than 85%RH;

温度-30°C以上, +80°C以下, 湿度85%以下的環境。

10.1.2. Avoid storing in the environment containing corrosive gas;

避免储存在有腐蚀性气体的环境中。

10.1.3. Avoid keeping it in the location with direct sunlight.

避免日光直射的场所。

10.1.4. Store using the standard packing without exerting force.

产品不可堆叠挤压保管。

10.2 The standard storage period is 12 months before opening the package. Preferably to be used as soon as possible. After opening the package, you should put the remaining switches in a plastic bag to prevent from damp and corrosive gas with maximum up to 3 months.

为开封的产品, 保存期限为12个月, 开封后未使用完的产品, 请标识区分, 并防潮防腐蚀气体, 开封后的产品, 保存期3个月。