



AOS
SEMICONDUCTOR

产品规格说明书

Product Data Sheet

AOS74AHCT1G125Gx

WEB | www.aossemi.cn 



电源管理IC



通信接口芯片



二三极管



LDO稳压器



逻辑器件



MOSFETs



运算放大器



显示驱动



MCU单片机



光电器件



AOS74AHCT1G125 Single Schmitt-Trigger Inverter

DESCRIPTION

The single buffer is designed for 2V to 5.5V V_{cc} operation. The AOS74AHCT1G125 device is single line driver with 3-state output. The output is disabled when the output-enable (\overline{OE}) input is high.

This device is fully specified for partial-power-down applications using I_{off} . The I_{off} circuitry disables the outputs, preventing damaging current backflow through the device when it is powered down.

To ensure the high-impedance state during power up or power down, \overline{OE} should be tied to V_{cc} through a pullup resistor, the minimum value of the resistor is determined by the current-sinking capability of the driver.

The AOS74AHCT1G125 is available in Green SOT23-5, SOT353(SC70-5) packages. It operates over an ambient temperature range of $-40^{\circ}C$ to $+125^{\circ}C$.

FEATURES

- Operating Voltage Range: 2.0V to 5.5V
- Low Power Consumption: 1 μ A(Max)
- Operating Temperature Range: $-40^{\circ}C$ to $+125^{\circ}C$
- Inputs Are TTL-Voltage Compatible
- $\pm 32mA$ Output Drive at $V_{cc}=5.0V$
- Latch-up Performance Exceeds 100mA
- Micro SIZE PACKAGES: SOT23-5, SOT353 (SC70-5)

APPLICATIONS

- AV Receiver
- Cable Modem Termination Systems
- Digital Picture Frame (DPF)
- High-Speed Data Acquisition and Generation
- Motor Controls: High-Voltage
- Personal Navigation Device(GPS)
- Portable Media Player

Functional Block Diagram

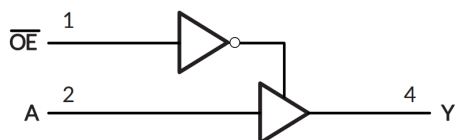

Device Information ⁽¹⁾

PART NUMBER	PACKAGE	BODY SIZE (NOM)
AOS74AHCT1G125	SOT23-5	2.92mm x 1.60mm
	SOT353 (SC70-5) (5)	2.10mm x 1.25mm

(1)For all available packages, see the orderable addendum at the end of the data sheet.

FUNCTION TABLE

INPUTS		OUTPUT
\overline{OE}	A	Y
L	H	H
L	L	L
H	X	Z

- H=HIGH Logic Level
- L=LOW Logic Level
- X=Don't Care
- Z=High-impedance OFF-state



PACKAGE/ORDERING INFORMATION

PRODUCT	ORDERING NUMBER	TEMPERATURE RANGE	PACKAGE LEAD	PACKAGE MARKING ⁽²⁾	MSL ⁽³⁾	PACKAGE OPTION
AOS74AHCT1G125	AOS74AHCT1G125GV	-40°C ~ +125°C	SOT23-5	1GT125	MSL3	Tape and Reel, 3000
	AOS74AHCT1G125GW	-40°C ~ +125°C	SC70-5 (SOT353)	1GT125	MSL3	Tape and Reel, 3000

NOTE:

- (1) This information is the most current data available for the designated devices. This data is subject to change without notice and revision of this document. For browser-based versions of this data sheet, refer to the right-hand navigation.
- (2) There may be additional marking, which relates to the lot trace code information (data code and vendor code), the logo or the environmental category on the device.
- (3) MSL, The Moisture Sensitivity Level rating according to the JEDEC industry standard classifications.

Marking Information

(1) SOT23-5, SC70-5(SOT353)

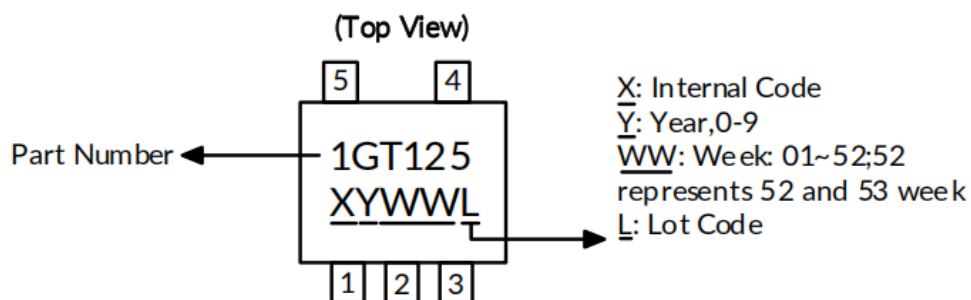



PIN CONFIGURATIONS

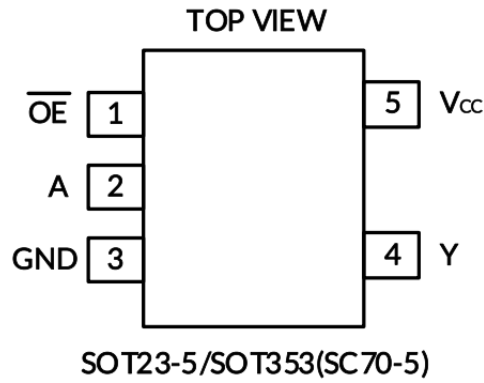

PIN DESCRIPTION

PIN	NAME	I/O TYPE ⁽¹⁾	FUNCTION
SOT23-5/SC70-5			
1	\overline{OE}	I	Enable/Input
2	A	I	A Input
3	GND	-	Ground Pin
4	Y	O	Y Output
5	V _{cc}	-	Power Pin

(1) I=input, O=output.



Specifications

Absolute Maximum Ratings⁽¹⁾Over operating free-air temperature range (unless otherwise noted)⁽¹⁾⁽²⁾

		MIN	MAX	UNIT	
V _{CC}	Supply voltage range	-0.5	6.5	V	
V _I	Input voltage range ⁽²⁾	-0.5	6.5		
V _O	Voltage range applied to any output in the high-impedance or power-off state ⁽²⁾	-0.5	6.5		
V _O	Voltage range applied to any output in the high or low state ⁽²⁾⁽³⁾	-0.5	V _{CC} +0.5		
I _{IK}	Input clamp current		-50	mA	
I _{OK}	Output clamp current		-50		
I _O	Continuous output current		± 50		
	Continuous current through V _{CC} or GND		± 100		
J _A	Package thermal impedance ⁽⁴⁾	SOT23-5		230	°C/W
		SC70-5 (SOT353)		380	
T _J	Junction temperature ⁽⁵⁾	-65	150	°C	
T _{stg}	Storage temperature	-65	150		

- (1) Stresses beyond those listed under *Absolute Maximum Ratings* may cause permanent damage to the device. These are stress ratings only, and functional operation of the device at these or any other conditions beyond those indicated under *Recommended Operating Conditions* is not implied. Exposure to absolute-maximum-rated conditions for extended periods may affect device reliability.
- (2) The input and output negative-voltage ratings may be exceeded if the input and output current ratings are observed.
- (3) The value of V_{CC} is provided in the *Recommended Operating Conditions* table.
- (4) The package thermal impedance is calculated in accordance with JESD-51.
- (5) The maximum power dissipation is a function of T_{J(MAX)}, R_{JA}, and T_A. The maximum allowable power dissipation at any ambient temperature is P_D = (T_{J(MAX)} - T_A) / R_{JA}. All numbers apply for packages soldered directly onto a PCB.



ESD Ratings

The following ESD information is provided for handling of ESD-sensitive devices in an ESD protected area only.

			VALUE	UNIT
V _(ESD)	Electrostatic discharge	Human-body model (HBM), MIL-STD-883K METHOD 3015.9	± 2000	V
		Charged-device model (CDM), ANSI/ESDA/JEDEC JS-002-2018	± 1000	
		Machine Model (MM), JESD22-A115C(2010)	± 200	



ESD SENSITIVITY CAUTION

ESD damage can range from subtle performance degradation to complete device failure. Precision integrated circuits may be more susceptible to damage because very small parametric changes could cause the device not to meet its published specifications.

**ELECTRICAL CHARACTERISTICS**

over recommended operating free-air temperature range (TYP values are at $T_A=+25^{\circ}\text{C}$, unless otherwise noted.) ⁽¹⁾

Recommended Operating Conditions

PARAMETER	SYMBOL	TEST CONDITIONS	MIN	MAX	UNIT
Supply Voltage	V_{CC}	Operating	2	5.5	V
High-level input voltage	V_{IH}	$V_{CC}=2V$	1		
		$V_{CC}=3.3V$	1.5		
		$V_{CC}=4.5V$ to $5.5V$	2		
Low-level input voltage	V_{IL}	$V_{CC}=2V$		0.3	
		$V_{CC}=3.3V$		0.55	
		$V_{CC}=4.5V$ to $5.5V$		0.8	
Input Voltage	V_i		0	5.5	
Output Voltage	V_o		0	V_{CC}	
Input transition rise or fall	t_r, t_f	$V_{CC}=2.0V$ to $5.5V$		5	
Operating Temperature	T_A		-40	125	$^{\circ}\text{C}$



Electrical Characteristics

PARAMETER		TEST CONDITIONS	V _{cc}	TEMP	MIN ⁽²⁾	TYP ⁽³⁾	MAX ⁽²⁾	UNIT
V _{OH}	I _{OH} =-100μA		2.0V to 5.5V		V _{cc} -0.1			V
	I _{OH} =-8mA		2.0		1.6			
	I _{OH} =-24mA		3.3		2.5			
	I _{OH} =-32mA		4.5V		3.8			
			5V		4.2			
			5.5V		4.8			
V _{OL}	I _{OH} =100μA		2.0V to 5.5V				0.1	
	I _{OH} =8mA		2.0				0.45	
	I _{OH} =24mA		3.3				0.55	
	I _{OH} =32mA		4.5V				0.55	
			5V				0.5	
			5.5V				0.45	
I _I	A or \overline{OE} inputs	V _I =5.5V or GND	0V to 5.5V	+25°C		± 0.1	± 1	μA
				Ful I			± 10	
I _{off}	V _I or V _O =5.5V		0	+25°C		± 0.1	± 1	
				Ful I			± 10	
I _{cc}	V _I =5.5V or GND, I _O =0		2.0V to 5.5V	+25°C		0.1	1	
				Ful I			10	
I _{ccT}	One input at 3.4V, Other inputs at V _{CC} or GND		5.5V	Ful I			500	
C _i (Input Capacitance)		V _{cc} =0V, f=10MHz	0V	+25°C		4		pF

- (1) All unused inputs of the device must be held at V_{cc} or GND to ensure proper device operation.
- (2) Limits are 100% production tested at 25°C. Limits over the operating temperature range are ensured through correlations using statistical quality control (SQC) method.
- (3) Typical values represent the most likely parametric norm as determined at the time of characterization. Actual typical values may vary over time and will also depend on the application and configuration.



AC Characteristics

PARAMETER		SYMBOL	TEST CONDITIONS		MIN ⁽²⁾	TYP ⁽³⁾	MAX ⁽²⁾	UNIT
Propagation Delay		t_{pd}	$V_{CC}=2.0V \pm 0.2V$	$C_L=30pF, R_L=500$		15.5		
			$V_{CC}=3.3V \pm 0.3V$	$C_L=50pF, R_L=500$		9.5		
			$V_{CC}=5V \pm 0.5V$	$C_L=50pF, R_L=500$		7.6		
Enable Time		t_{en}	$V_{CC}=2.0V \pm 0.2V$	$C_L=30pF, R_L=500$		15.8		ns
			$V_{CC}=3.3V \pm 0.3V$	$C_L=50pF, R_L=500$		9.5		
			$V_{CC}=5V \pm 0.5V$	$C_L=50pF, R_L=500$		8		
Disable Time		t_{dis}	$V_{CC}=2.0V \pm 0.2V$	$C_L=30pF, R_L=500$		9		
			$V_{CC}=3.3V \pm 0.3V$	$C_L=50pF, R_L=500$		8.5		
			$V_{CC}=5V \pm 0.5V$	$C_L=50pF, R_L=500$		7.3		
Power dissipation capacitance	Output enabled	C_{pd}	$V_{CC}=5V$	$f=10MHz$		40		pF
	Output disabled					4		

- (1) All unused inputs of the device must be held at V_{CC} or GND to ensure proper device operation.
- (2) This parameter is ensured by design and/or characterization and is not tested in
- (3) Typical values represent the most likely parametric norm as determined at the time of characterization. Actual typical values may vary over time and will also depend on the application and configuration.



Parameter Measurement Information

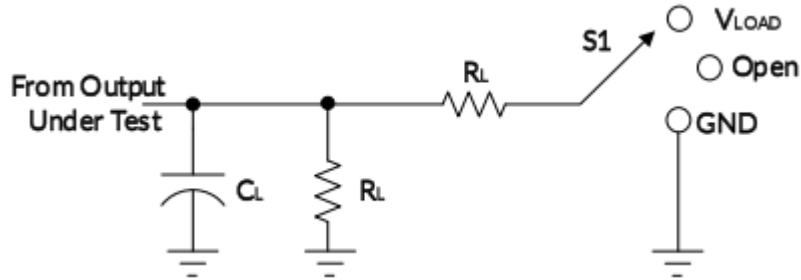

TEST	S1
t_{PLH}/t_{PHL}	Open
t_{PLZ}/t_{PZL}	V_{LOAD}
t_{PHZ}/t_{PZH}	GND

V_{CC}	INPUTS		V_M	V_{LOAD}	C_L	R_L	V
	V_i	t_r/t_f					
$2.0V \pm 0.2V$	V_{CC}	$\leq 2ns$	$V_{CC}/2$	$2 \times V_{CC}$	30pF	500	0.15V
$3.3V \pm 0.3V$	3V	$\leq 2.5ns$	1.5V	6V	50pF	500	0.3V
$5V \pm 0.5V$	V_{CC}	$\leq 2.5ns$	$V_{CC}/2$	$2 \times V_{CC}$	50pF	500	0.3V

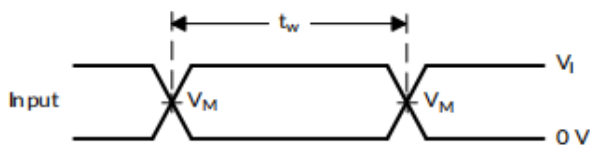

VOLTAGE WAVEFORMS PULSE DURATION

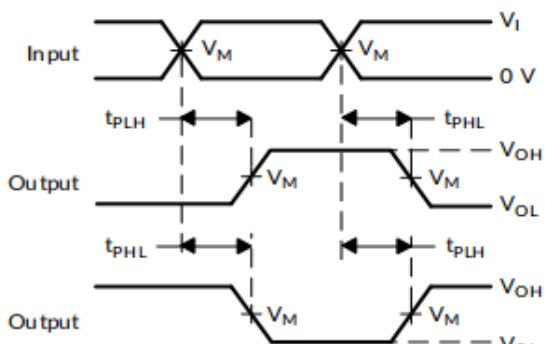

VOLTAGE WAVEFORMS PROPAGATION DELAY TIMES INVERTION AND NON INVERTING OUTPUTS

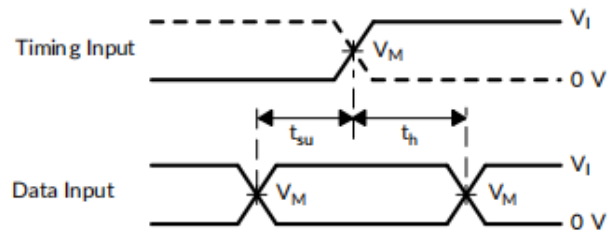

VOLTAGE WAVEFORMS SETUP AND HOLD TIMES

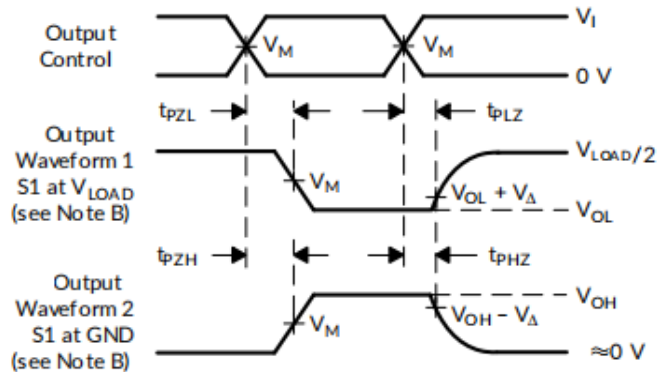

VOLTAGE WAVEFORMS ENABLE AND DISABLE TIMES LOW-AND HIGH-LEVEL ENABLING



- NOTES:
- A. C_L includes probe and jig capacitance.
 - B. Waveform 1 is for an output with internal conditions such that the output is low, except when disabled by the output control.
Waveform 2 is for an output with internal conditions such that the output is high, except when disabled by the output control.
 - C. All input pulses are supplied by generators having the following characteristics: $PRR \leq 10\text{MHz}$, $Z_0 = 50 \Omega$.
 - D. The outputs are measured one at a time, with one transition per measurement.
 - E. t_{PLZ} and t_{PHZ} are the same as t_{dis} .
 - F. t_{PZL} and t_{PZH} are the same as t_{en} .
 - G. t_{PLH} and t_{PHL} are the same as t_{pd} .
 - H. All parameters and waveforms are not applicable to all devices.

Figure 1. Load Circuit and Voltage Waveforms



PACKAGE OUTLINE DIMENSIONS

SOT23-5⁽³⁾

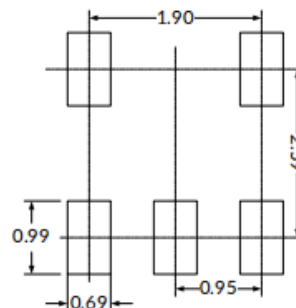
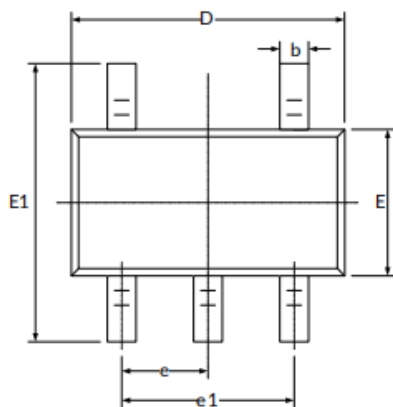

RECOMMENDED LAND PATTERN (Unit: mm)

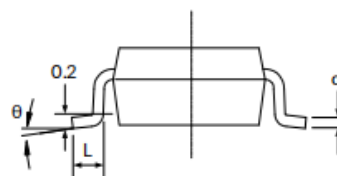
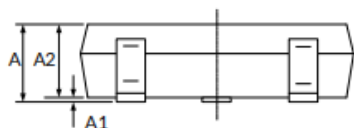

Symbol	Dimensions In Millimeters		Dimensions In Inches	
	Min	Max	Min	Max
A ⁽¹⁾	1.050	1.250	0.041	0.049
A1	0.000	0.100	0.000	0.004
A2	1.050	1.150	0.041	0.045
b	0.300	0.500	0.012	0.020
c	0.100	0.200	0.004	0.008
D ⁽¹⁾	2.820	3.020	0.111	0.119
E ⁽¹⁾	1.500	1.700	0.059	0.067
E1	2.650	2.950	0.104	0.116
e	0.950 (BSC) ⁽²⁾		0.037 (BSC) ⁽²⁾	
e1	1.800	2.000	0.071	0.079
L	0.300	0.600	0.012	0.024
	0°	8°	0°	8°

NOTE:

1. Plastic or metal protrusions of 0.15mm maximum per side are not included.
2. BSC (Basic Spacing between Centers), "Basic" spacing is nominal.
3. This drawing is subject to change without notice.



SOT353(SC70-5)⁽³⁾

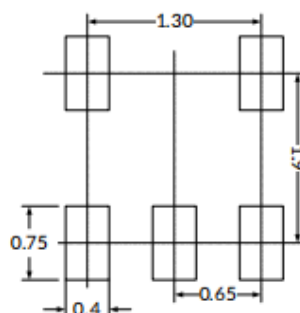
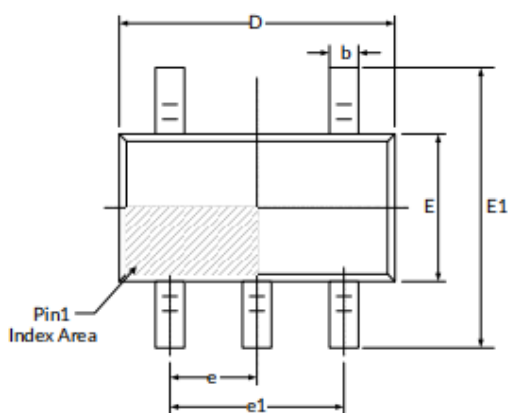

RECOMMENDED LAND PATTERN (Unit: mm)

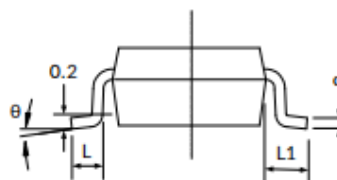
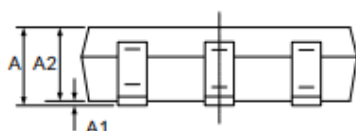

Symbol	Dimensions In Millimeters		Dimensions In Inches	
	Min	Max	Min	Max
A ⁽¹⁾	0.900	1.100	0.035	0.043
A1	0.000	0.100	0.000	0.004
A2	0.900	1.000	0.035	0.039
b	0.150	0.350	0.006	0.014
c	0.080	0.150	0.003	0.006
D ⁽¹⁾	2.000	2.200	0.079	0.087
E ⁽¹⁾	1.150	1.350	0.045	0.053
E1	2.150	2.450	0.085	0.096
e	0.650(BSC) ⁽²⁾		0.026(BSC) ⁽²⁾	
e1	1.300(BSC) ⁽²⁾		0.051(BSC) ⁽²⁾	
L	0.260	0.460	0.010	0.018
L1	0.525		0.021	
	0°	8°	0°	8°

NOTE:

1. Plastic or metal protrusions of 0.15mm maximum per side are not included.
2. BSC (Basic Spacing between Centers), "Basic" spacing is nominal.
3. This drawing is subject to change without notice.



TAPE AND REEL INFORMATION

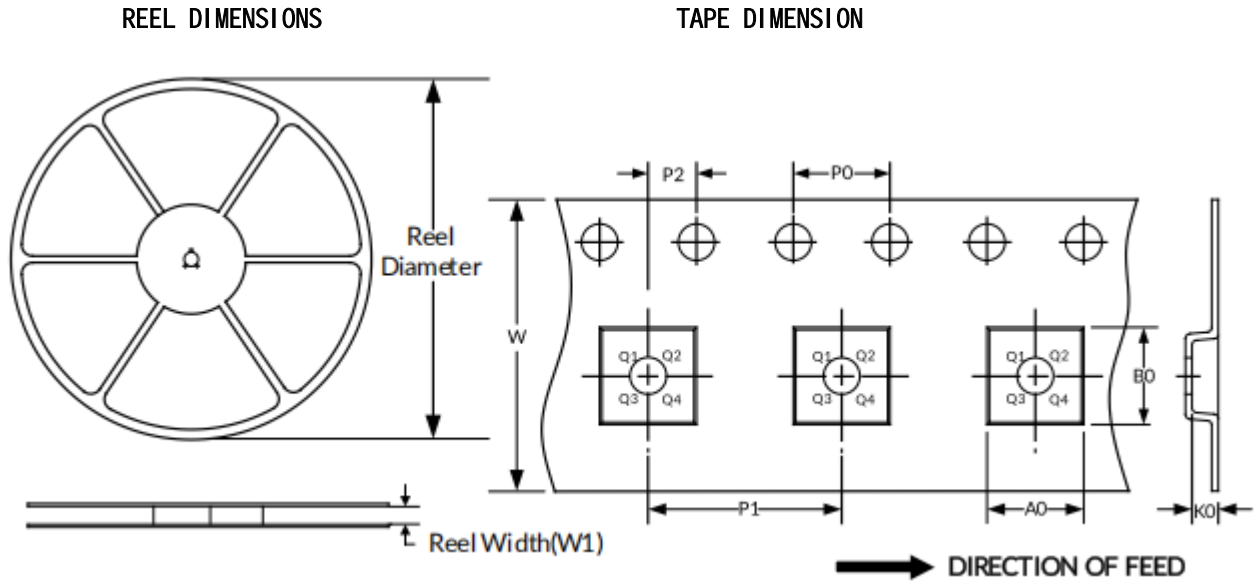

NOTE: The picture is only for reference. Please make the object as the standard.

KEY PARAMETER LIST OF TAPE AND REEL

Package Type	Reel Diameter	Reel Width(mm)	A0 (mm)	B0 (mm)	K0 (mm)	P0 (mm)	P1 (mm)	P2 (mm)	W (mm)	Pin1 Quadrant
SOT353(SC70-5)	7''	9.5	2.25	2.55	1.20	4.0	4.0	2.0	8.0	Q3
SOT23-5	7''	9.5	3.20	3.20	1.40	4.0	4.0	2.0	8.0	Q3

NOTE:

1. All dimensions are nominal.
2. Plastic or metal protrusions of 0.15mm maximum per side are not included.