

Programmable Current Limit Switches

FEATURES

- Wide input voltage range from 2.7V to 7V
- Maximum input DC voltage is 24V
- Integrated low R_{on} switch: 50 m Ω
- Programmable current limit from 250mA to 3A
- $\pm 7\%$ current limit accuracy at $T_A=+25^\circ\text{C}$
- Programmable over voltage protection
- OVP threshold adjustable range up to 7V
- Short circuit protection
AW35020: Latched-Off
AW35020A: Auto-Recovery
- Programmable soft start
- Thermal shutdown protection
AW35020: Latched-Off
AW35020A: Auto-Recovery
- Fault output
- Enable interface pin
- DFN 3mmx2mmx0.75mm-8L

GENERAL DESCRIPTION

AW35020/AW35020A is a smart e-Fuse with robust overcurrent and overvoltage protection. It's applied to 5V DC buses.

AW35020/AW35020A uses N-channel MOSFET as power switch, and allows the user to program the current-limit threshold between 250mA to 3A with an external resistor when the load exceeds the current-limit threshold.

AW35020/AW35020A can withstand 24V DC voltage, and shuts down in the event V_{IN} exceeds overvoltage threshold. Overvoltage threshold is programmed by external resistors.

Additional features include enable, under-voltage, over-temperature, output discharge and fault flag output are provided to monitor system status.

APPLICATIONS

- White goods, Appliances
- Set-top boxes, DVD and Gaming consoles
- HDD and SSD drives
- Adapter power devices
- Smart meters, Gas analyzers
- Smart load switches/USB switches

TYPICAL APPLICATION CIRCUIT

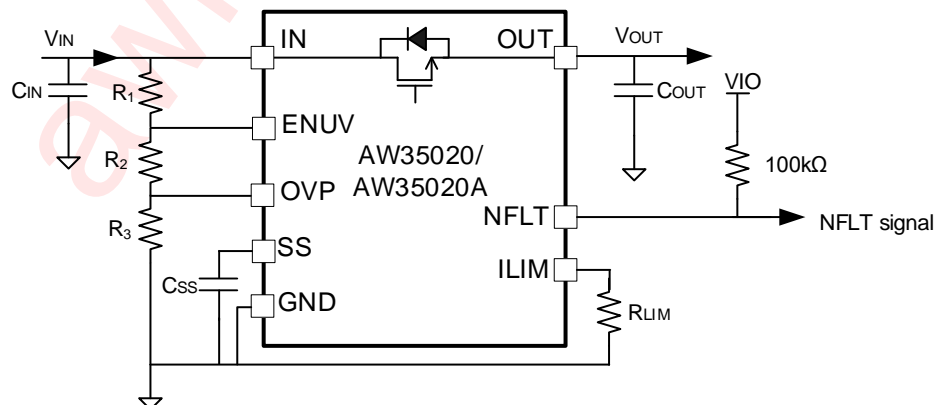

Figure 1 Typical Application Circuit

All the trademarks mentioned in the document are the property of their owners.

PIN CONFIGURATION

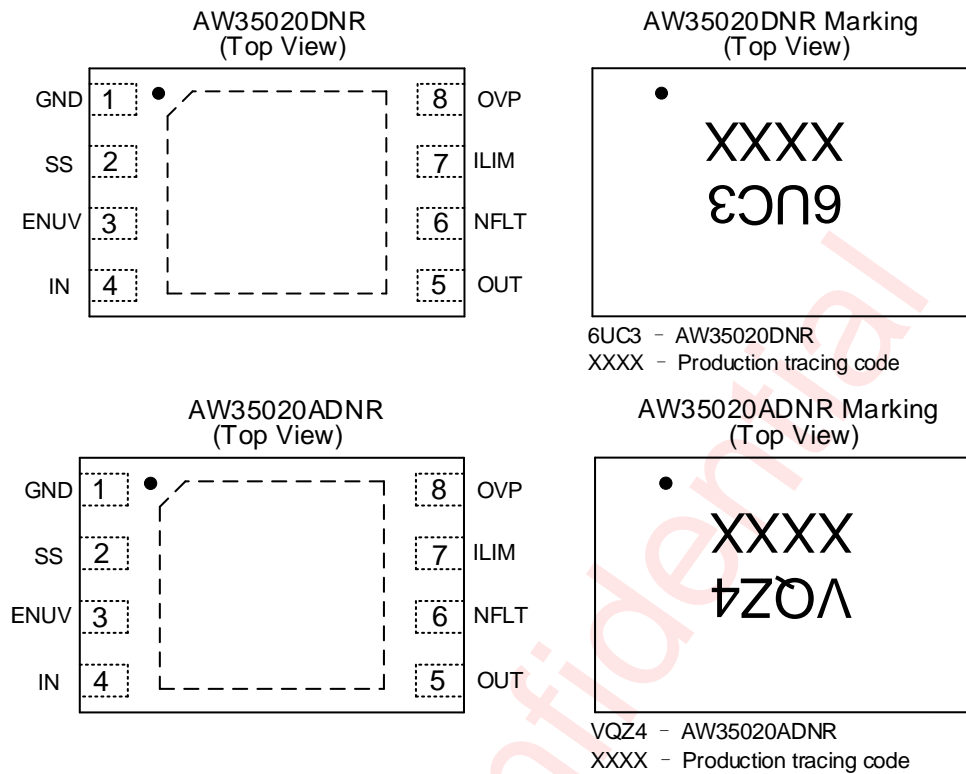

Figure 2 Pin Configuration

PIN DEFINITION

PIN	NAME	DESCRIPTION
1	GND	Ground.
2	SS	Soft start pin. Connect a capacitor from this pin to GND to set the slew rate of OUT during device turn-on.
3	ENUV	Chip enable and UVLO pin. When ENUV is driven high, the power switch is enabled. When it is driven low, turn power switch off. Setting programmable threshold of UVLO. When pulled to GND, resets the thermal fault latch.
4	IN	Power input. Supply voltage of the device.
5	OUT	Power output.
6	NFLT	Active-low open-drain output, connect a pull up resistor to high. Asserted low during over voltage, under voltage, short circuit, over temperature and fast-trip.
7	ILIM	An external resistor from this pin to GND. Setting current limit threshold. Recommended $25\text{ k}\Omega \leq \text{RILIM} \leq 300\text{ k}\Omega$. When ILIM shorts to GND, current-limit threshold is about 200mA; when ILIM floats, current limit threshold is about 4A.
8	OVP	Over voltage detection pin. Setting programmable threshold voltage of over voltage protection by external resistors.
PAD	Thermal pad	Internally connected to GND; used to heat-sink the part to the circuit board traces. Connect Thermal PAD to GND terminal externally.

TYPICAL APPLICATION CIRCUITS

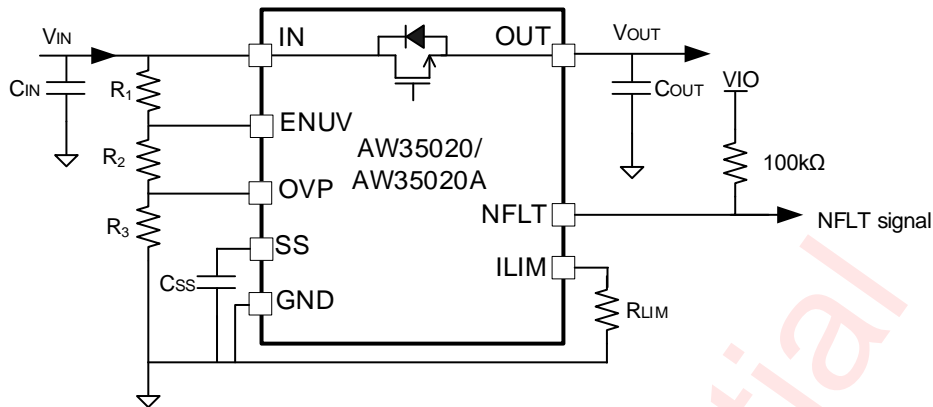

Figure 4 Application Circuit

Notice for Typical Application Circuits:

1. All peripheral devices should be as close as possible to the chip, C_{IN} , C_{OUT} , C_{SS} should be close to V_{IN} , V_{OUT} , SS pins respectively. Besides the metal traces between them should be short and wide.
2. Place R_1 , R_2 , R_3 as close as OVP. The traces routing the R_{LIM} resistor to the device must be as short as possible to reduce parasitic effects on the current limit accuracy.
3. If NFLT is not used, it can be left floating.
4. IN, OUT support 3A current, the routing lines should be as wide as possible.
5. The Thermal PAD must be directly connected to PCB ground plane using wide and short copper trace.

DEVICE COMPARISON TABLE

Part Number	Over Temperature Protection	Short Circuit Protection	Current Limit
AW35020DNR	Latch-Off	Latch-Off	Latch-Off
AW35020ADNR	Auto-Recovery	Auto-Recovery	Current limit threshold decreases to soft-start current limit threshold I_{LIM_ST} (NOTE1)

NOTE1: I_{LIM_ST} is about 50%* I_{LIM} .

ORDERING INFORMATION

Part Number	Temperature	Package	Marking	Moisture Sensitivity Level	Environmental Information	Delivery Form
AW35020DNR	-40°C to 105°C	WBDFN 3mmx2mm-8L	6UC3	MSL1	ROHS+HF	3000 units/ Tape and Reel
AW35020ADNR	-40°C to 105°C	WBDFN 3mmx2mm-8L	VQZ4	MSL1	ROHS+HF	3000 units/ Tape and Reel

ABSOLUTE MAXIMUM RATINGS (NOTE2)

PARAMETERS		RANGE
Input voltage range	IN, ENUV, OVP	-0.3V to 28V
	SS, ILIM	-0.3V to 6V
Output voltage range	NFLT	-0.3V to 28V
	OUT	-0.3V to 7V
Junction-to-ambient thermal resistance θ_{JA} (NOTE3)		78°C/W
Power dissipation P_D (NOTE4)		1.5W
Operating free-air temperature range		-40°C to 105°C
Maximum operating junction temperature T_{JMAX}		150°C
Storage temperature T_{STG}		-65°C to 150°C
Lead temperature (soldering 10 seconds)		260°C
ESD and Latch-Up		
HBM (Human Body Model) (NOTE5)		±2kV
CDM (NOTE6)		±1.5kV
Latch-Up (NOTE7)		±200mA

NOTE2: Conditions out of those ranges listed in “absolute maximum ratings” may cause permanent damages to the device. In spite of the limits above, functional operation conditions of the device should within the ranges listed in “recommended operating conditions”. Exposure to absolute-maximum-rated conditions for prolonged periods may affect device reliability.

NOTE3: Thermal resistance from junction to ambient is highly dependent on PCB layout.

NOTE4: Maximum power dissipation, $T_A=25^\circ\text{C}$

NOTE5: The human body model is a 100pF capacitor discharged through a 1.5kΩ resistor into each pin. Test method: ESDA/JEDEC JS-001-2017

NOTE6: Test method: ESDA/JEDEC JS-002-2018

NOTE7: Test method: JESD78E

RECOMMENDED OPERATING CONDITIONS

SYMBOL	PARAMETER	MIN	TYP	MAX	UNIT
V_{IN}	Power voltage	2.7		7	V
$V_{OUT}, V_{NFLT}, V_{ENUV}, V_{OVP}$	Input/output voltage	0		7	V
V_{SS}, V_{ILIM}	SS, ILIM voltage	0		5.5	V
I_{OUT}	Current limit	0.25		3	A
T_A	Ambient temperature	-40		85	°C
R_{LIM}	Current-limit set resistor	25		300	kΩ
C_{IN}	Input capacitor	0.1	1	100	μF
C_{OUT}	Output capacitor	1		100	μF

ELECTRICAL CHARACTERISTICS

$T_A = 25^\circ\text{C}$, $V_{IN} = 2.7\text{V}$ to 7V , $V_{ENUV}=2\text{V}$, $V_{OVP}=0\text{V}$, $R_{LIM}=100\text{k}\Omega$, SS float, $C_{IN} = 1\mu\text{F}$, $C_{OUT} = 1\mu\text{F}$, unless otherwise noted.

SYMBOL	DESCRIPTION	TEST CONDITION	MIN	TYP	MAX	UNIT
POWER SUPPLY AND INTERNAL UVLO						
V_{UVLO}	Power under voltage lockout	V_{IN} rising	2.45	2.55	2.65	V
V_{UVLO_HYS}	Power under voltage lockout hysteresis			100		mV
I_{Q_OFF}	Supply current, disable	$V_{ENUV}=0\text{V}$, $V_{IN}=5\text{V}$		0.1	1	μA
I_{Q_ON}	Supply current, enable	$V_{ENUV}=2\text{V}$, $V_{IN}=5\text{V}$, OUT float		200	480	μA
INPUT OVER VOLTAGE PROTECTION						
V_{OVPR}	Over voltage threshold, rising	OVP rising	1.36	1.39	1.42	V
V_{OVPF}	Over voltage threshold, falling	OVP falling	1.29	1.32	1.35	V
I_{OVP}	OVP input leakage current	$0\text{V} \leq V_{OVP} \leq 5\text{V}$	-0.1	0	0.1	μA
t_{OVP_DELAY}	OVP disable delay	OVP \uparrow to $V_{OUT}\downarrow$	0.4	1	1.6	μs
ENABLE AND UNDER VOLTAGE LOCKOUT INPUT						
V_{ENUVR}	ENUV threshold voltage, rising	ENUV rising	1.35	1.38	1.42	V
V_{ENUVF}	ENUV threshold voltage, falling	ENUV falling	1.29	1.32	1.35	V
I_{ENUV}	ENUV input leakage current	$0\text{V} \leq V_{ENUV} \leq 5\text{V}$	-0.1	0	0.1	μA
t_{OFF_DELAY}	Turn off delay	ENUV \downarrow to $V_{OUT}\downarrow$		3		μs
t_{ON_DELAY}	Turn on delay	ENUV \uparrow to $V_{OUT}=1\text{V}$, SS float		170		μs
SOFT START: OUTPUT RAMP CONTROL						
I_{SS}	SS sourcing current	$V_{SS}=1\text{V}$	0.5	1	1.5	μA
R_{SS}	SS discharging resistance	$V_{ENUV}=0\text{V}$, $I_{SS}=10\text{mA}$ sinking	47	62	77	Ω
V_{SSMAX}	SS maximum capacitor voltage	$V_{IN}=7\text{V}$		5.5		V
$GAIN_{SS}$	SS to OUT Gain	$\Delta V_{OUT}/\Delta V_{SS}$	4.6	5.5	6.4	V/V
t_{rise}	Output ramp time	ENUV \uparrow to $V_{OUT}=4.5\text{V}$, with SS float, $C_{OUT}=1\mu\text{F}$		0.30		ms
		ENUV \uparrow to $V_{OUT}=4.5\text{V}$, with $C_{SS}=1.2\text{nF}$, $C_{OUT}=1\mu\text{F}$		1.28		

ELECTRICAL CHARACTERISTICS (CONTINUED)

$T_A = 25^\circ\text{C}$, $V_{IN} = 2.7\text{V to } 7\text{V}$, $V_{ENUV}=2\text{V}$, $V_{OVP}=0\text{V}$, $R_{LIM}=100\text{k}\Omega$, SS float, $C_{IN} = 1\mu\text{F}$, $C_{OUT} = 1\mu\text{F}$, unless otherwise noted.

SYMBOL	DESCRIPTION	TEST CONDITION	MIN	TYP	MAX	UNIT
POWER MOSFET SWITCH						
R_{ON}	Switch on resistance	$V_{IN}=5\text{V}$, $R_{LIM}=50\text{k}$, $I_{OUT}=0.2\text{A}$	30	50	70	m Ω
		$V_{IN}=5\text{V}$, $R_{LIM}=50\text{k}$, $I_{OUT}=0.35\text{A}$	30	50	70	m Ω
PASS FET OUTPUT						
I_{LKG_OUT}	OUT bias current in off state	$V_{ENUV}=0\text{V}$, $V_{OUT}=0\text{V}$ (Sourcing)	-0.5	0.1	0.5	μA
I_{SNK_OUT}		$V_{ENUV}=0\text{V}$, $V_{OUT}=0.3\text{V}$ (Sinking)		0.8		mA
CURRENT LIMIT PROGRAMMING						
I_{LIMB}	ILIM pin bias current	$V_{LIM}=0.5\text{V}$	4.5	5	5.5	μA
I_{LIM}	Current limit	$V_{IN}=5\text{V}$, $R_{LIM}=50\text{k}\Omega$, $T_A=25^\circ\text{C}$	0.450	0.500	0.550	A
		$V_{IN}=5\text{V}$, $R_{LIM}=200\text{k}\Omega$, $T_A=25^\circ\text{C}$	1.860	2.000	2.140	A
$t_{FAST_TRIP_DLY}$	Fast trip comparator delay	$I_{OUT}>I_{FAST_TRIP}$		1		μs
FAULT FLAG						
R_{NFLT}	NFLT pull down resistance	$V_{ENUV}=0\text{V}$, $I_{NFLT}=1\text{mA}$	19	27	35	Ω
I_{NFLT}	NFLT input leakage current	Device not in fault condition, $V_{NFLT}=0\text{V}$, 5V	-0.5	0	0.5	μA
THERMAL SHUT DOWN						
T_{SDN}	Thermal shutdown threshold	Temperature rising		140		$^\circ\text{C}$
T_{SDNHYS}	Thermal Shutdown Hysteresis			20		$^\circ\text{C}$
t_{TSD_DLY}	Retry delay after thermal shutdown recovery	$V_{IN}=5\text{V}$		130		ms

TIMING DIAGRAM

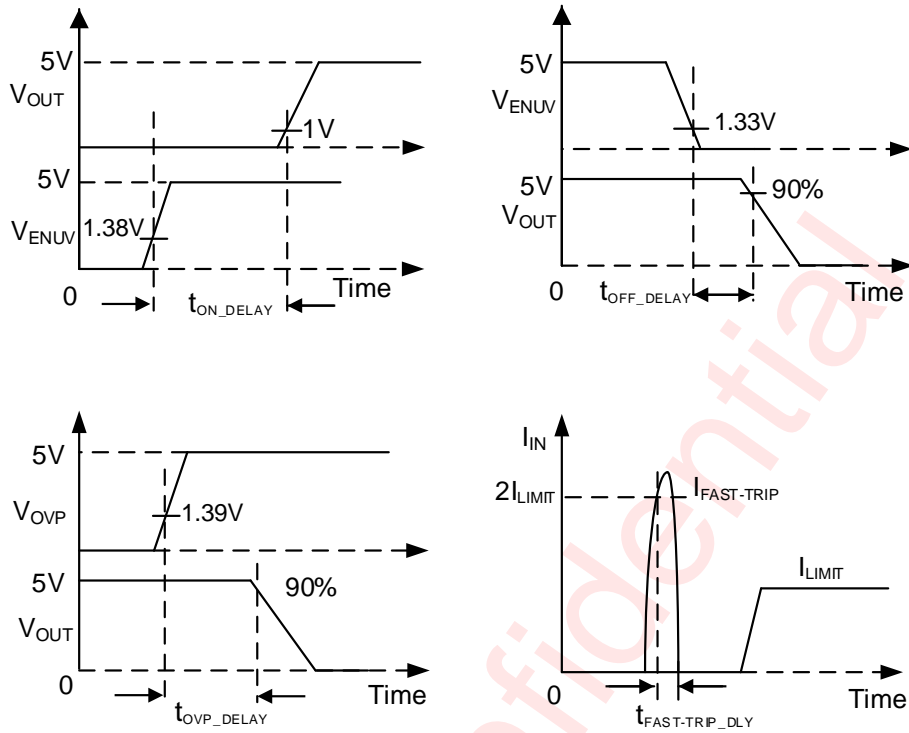

Figure 5 Timing diagram

TYPICAL CHARACTERISTICS

Ambient temperature is 25°C, $V_{IN}=2.7V$ to $24V$, $C_{IN} = 1\mu F$, $C_{OUT}=1\mu F$, $V_{ENUV}=2V$, $V_{OVLP}=0V$, $R_{LIM}=100k\Omega$, SS float, unless otherwise noted.

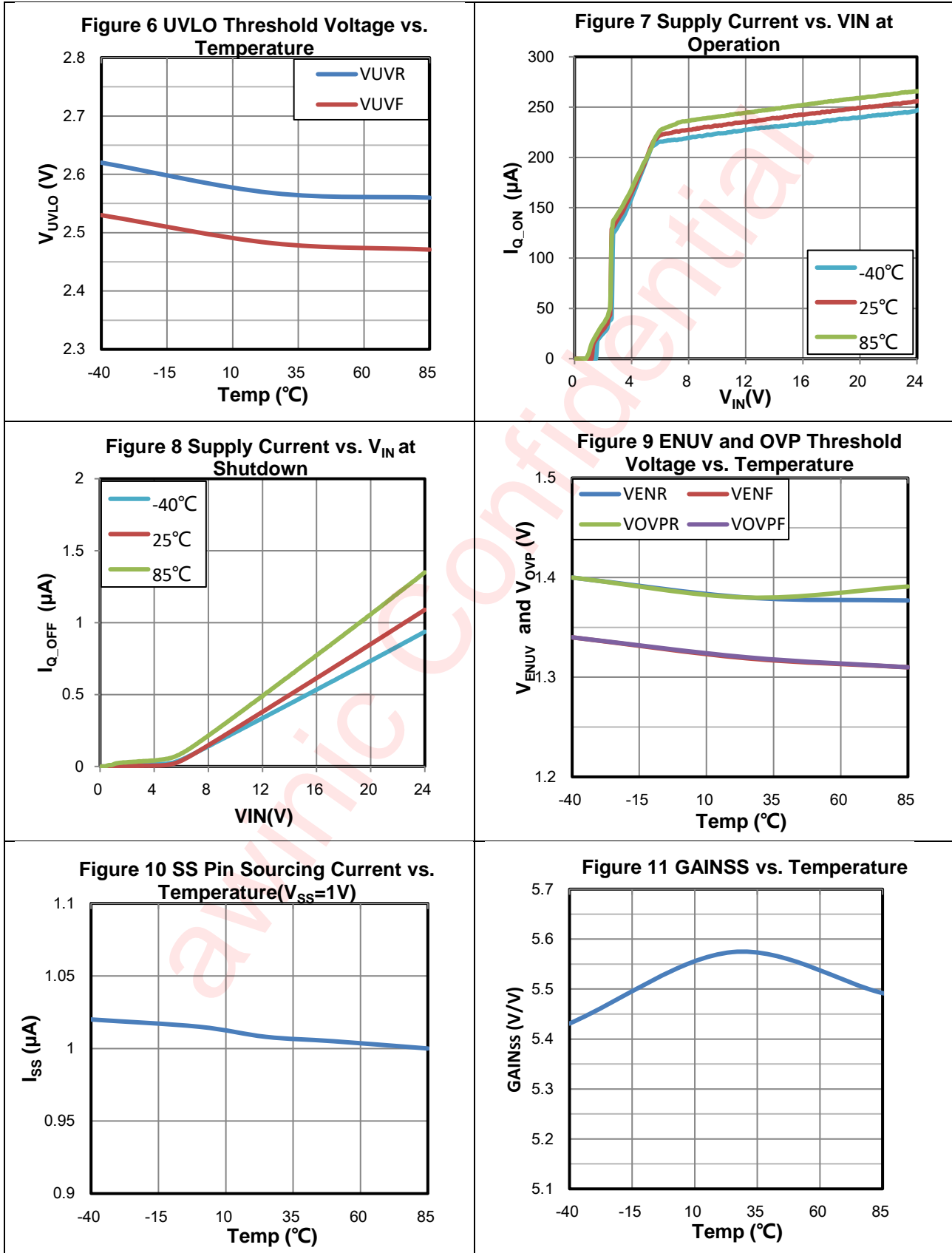

Figure 12 Output Ramp Time vs. Soft-Start Capacitor $V_{IN}=12V$

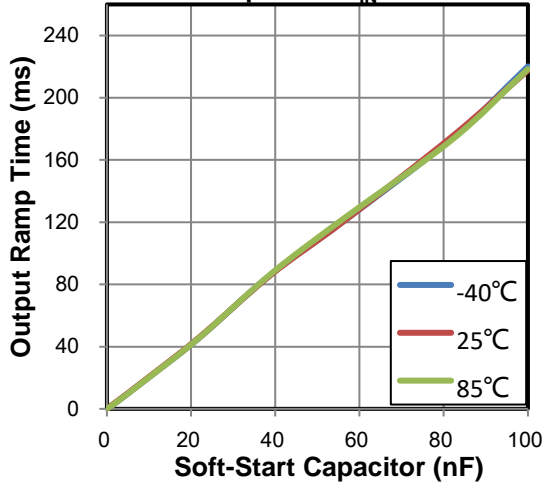

Figure 13 Output Ramp Time vs. Temperature with SS float $V_{IN}=12V$

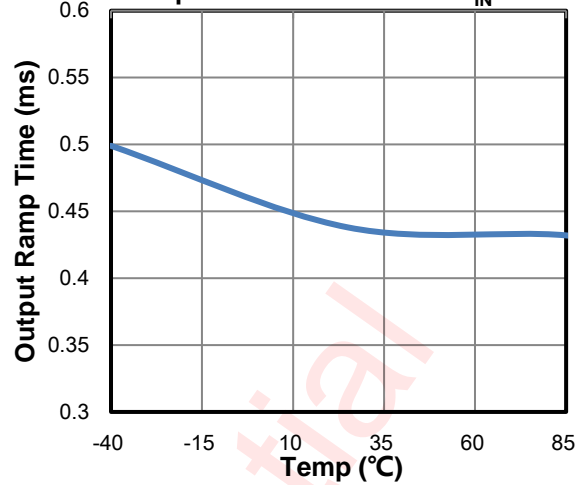

Figure 14 Current Limit vs. Temperature

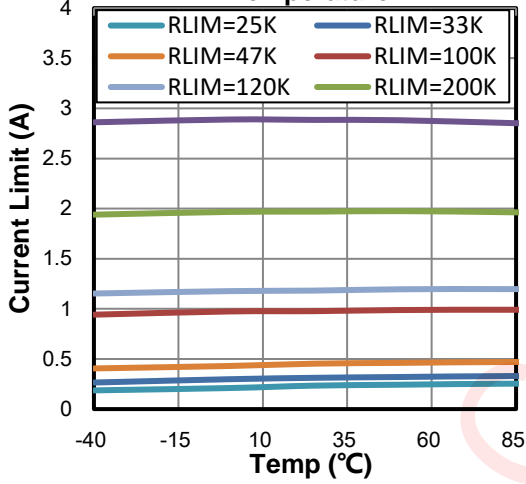

Figure 15 Current Limit vs. Temperature

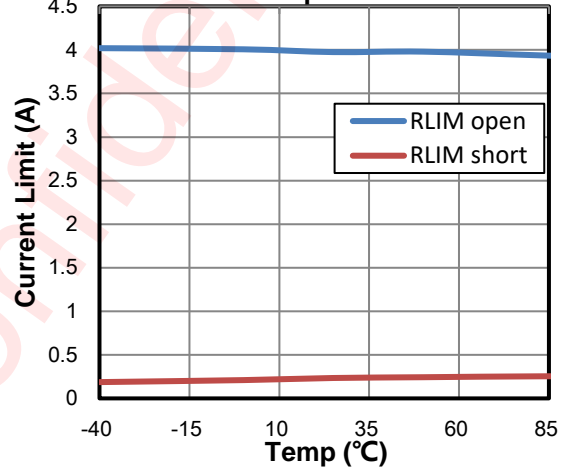

Figure 16 RDSON vs. Temperature

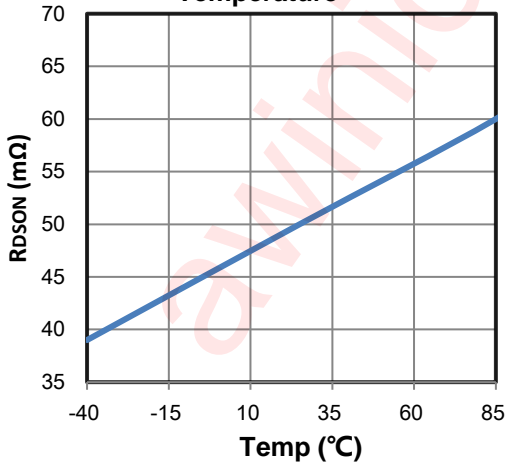

Figure 17 Current Limit vs. Current Limit Resistor

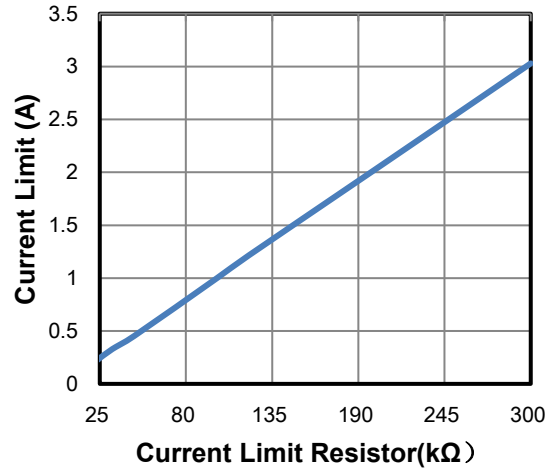

Figure 18 Turn-On with Enable

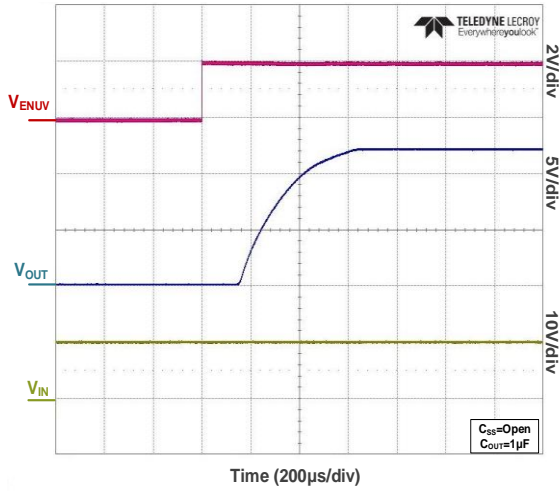

Figure 19 Turn-On with Enable

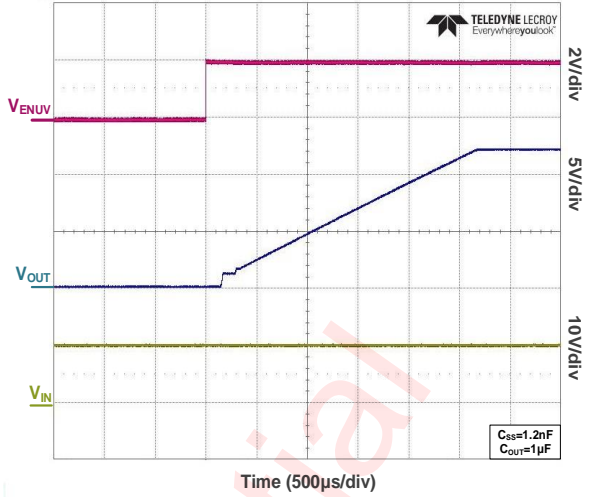

Figure 20 ENUV Turn-On Delay: ENUV↑ to Output Ramp↑

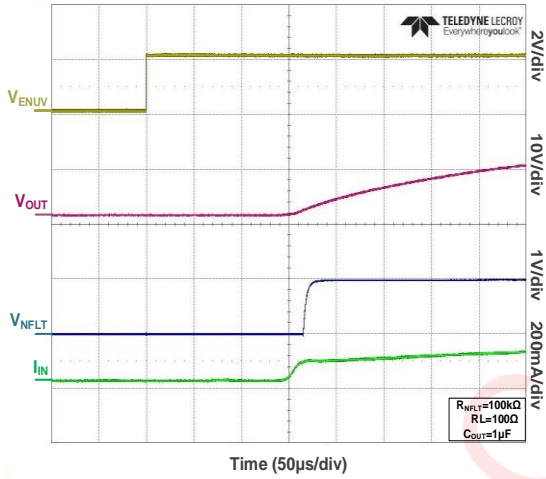

Figure 21 ENUV Turn-Off Delay: ENUV↓ to Fault↓

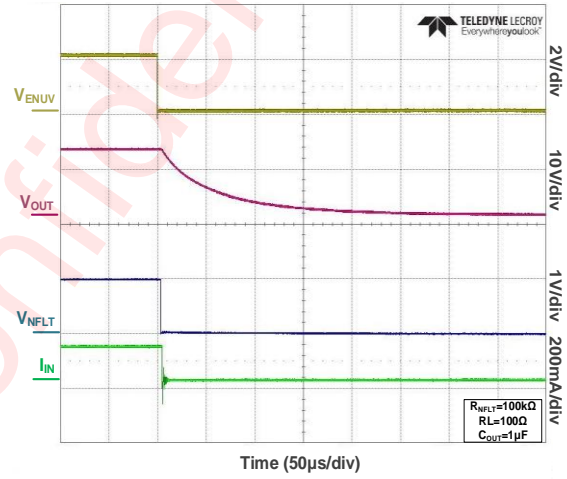

Figure 22 ENUV Turn-On Delay: OVP↓ to Output Ramp↑

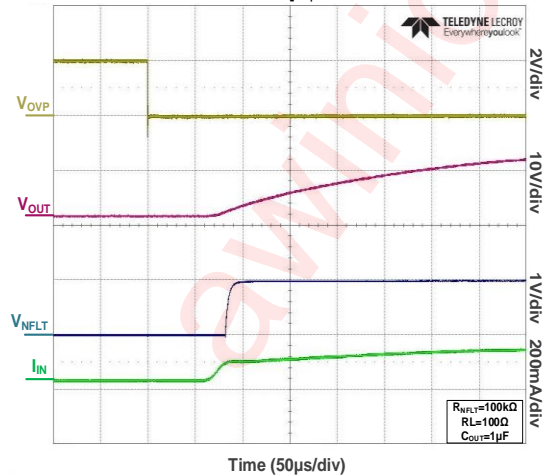
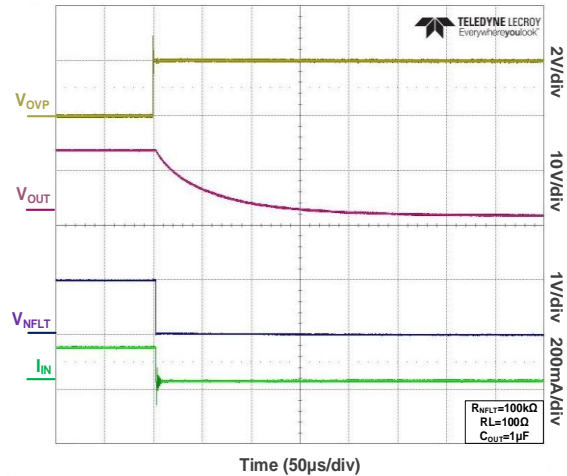

Figure 23 ENUV Turn-Off Delay: OVP↑ to Fault↓



DETAILED FUNCTIONAL DESCRIPTION

The AW35020/AW35020A is a smart e-Fuse with enhanced built-in protection circuitry. It provides robust protection for all systems and applications powered from 2.7V to 7V.

For hot-plug-in boards, the device provides in-rush current control and programmable output ramp rate. AW35020/AW35020A integrate over current and short circuit protections. The precision over current limit helps to minimize over design of the input power supply, while the fast response short circuit protection immediately isolates the load from input when a short circuit is detected. The device allows the user to program the over current limit threshold between 0.25A and 3A via an external resistor. The device provides precision monitoring of voltage bus for brown out and over voltage conditions of voltage bus for brown out and over voltage conditions and asserts fault for downstream system. AW35020/AW35020A is designed to protect systems such as White Goods, STBs, DTVs, Smart Meters and Gas Analyzers.

Enable

ENUV enables the control circuits, and power switch when $V_{ENUV} > 1.38V$. It turns off power switch when $V_{ENUV} < 1.33V$. When V_{ENUV} is low, it will reset AW35020 that have latched off due to a fault condition.

The under-voltage lockout threshold is programmed by external divider resistors connecting IN and GND. If the under-voltage lockout function is not used, ENUV pin should be connected to DC voltage which is bigger than 2V. It cannot be floated. AW35020/AW35020A also has internal under-voltage (about 2.55V) lockout circuitry.

Over Voltage Protection

OVP pin connects external divider resistors to IN and GND to program over voltage threshold. When external over voltage protection is not used, connect OVP pin to GND. When over voltage event happens, power switch turns off to protect downstream load.

Over voltage protection threshold voltage is:

$$V_{OVP} = \frac{1.39 \times (R_1 + R_2 + R_3)}{R_3}$$

Soft Start

AW35020/AW35020A is designed to control the in-rush current. SS pin programs the maximum slew rate of the output voltage at power-on by connecting an external capacitor C_{SS} to GND. The equation is shown in the following:

$$\frac{dV_{OUT}}{dt} = \frac{I_{SS} \times GAIN_{SS}}{C_{SS}}$$

I_{SS} is 1 μ A, $GAIN_{SS}$ is 5.5 V/V.

During start up, Power MOSFET current limit value I_{LIM_ST} is small. I_{LIM_ST} is about 50%* I_{LIM} (NOTE8). So AW35020/AW35020A can't start up with heavy load bigger than I_{LIM_ST} . If OUT connect a big capacitance C_{OUT} to GND, SS should connect capacitance C_{SS} to GND to increase soft start time. When SS voltage rises to 1V and soft start time is bigger than 1ms, Short circuit protection monitor is available. During this time, OUT must rise above 2V, otherwise it will trigger short circuit protection, and Power MOSFET turns off.

When OUT load current is I_{LOAD} , and OUT rises to 2V, charging time of C_{OUT} is:

$$t_{OUT_2V} = \frac{2V \times C_{OUT}}{I_{LIM_ST} - I_{LOAD}}$$

When SS rises from 0V to 1V, SS rising time is:

$$t_{SS_1V} = \frac{1V \times C_{SS}}{1\mu A}$$

The condition that VOUT builds up successfully is: $t_{SS_1V} > t_{OUT_2V}$, and $I_{LOAD} < I_{LIM_ST}$. The following equation must satisfy:

$$C_{SS} > \frac{2 \times 10^{-6} \times C_{OUT}}{I_{LIM_ST} - I_{LOAD}}$$

NOTE8: 50%* I_{LIM} is tested under the following condition: $V_{IN} = 5V$, OUT start up with 1 Ω resistance and 1 μ F capacitance to GND.

Over Load and Short Circuit Protection

Load current is monitored by sensing voltage across an internal sense resistor. Current limit threshold is programmed by connecting external resistor R_{LIM} to GND.

$$I_{LIM} = 1.01 \times 10^{-5} \times R_{LIM} - 0.012$$

When over load happens, output current is limited to the current limit threshold, and current limit holds on for 500μs, power switch latches off for AW35020 and current limit decreases to soft-start current limit value for AW35020A. Pull down the ENUV signal and the latch state will be cleared. For better protection from a hard short-to-GND condition (when the ENUV pins are enabled, a short to GND occurs suddenly), the device implements a fast-trip protection to turn off the related channel before the current-limit closed loop is set up. With this fast response, the device can achieve better inrush current-suppression performance. The fast-trip threshold current is 2xI_{LIM}. Fast-trip comparator shuts down power switch for 40μs, then the device attempts to turn on power switch and allows the current limit loop to regulate the output current to I_{LIM} again.

When short circuit protection happens, power switch will latch off for AW35020 and turn off to commence an auto-recovery cycle for AW35020A with hic-cup time 130ms.

NFLT Fault Report

NFLT pin is asserted low during over voltage, under-voltage, thermal shut down and fast-trip. It is de-asserted after the fault condition is removed and then recover normal operation. It's recommended to be pulled up by 100kΩ pull-up resistor to I/O rail. During normal operation, NFLT is pulled up to logic high by pull-up resistor, when fault event happens, NFLT will output logic low.

Thermal Shutdown

The device has a built-in temperature sensor which monitors the internal junction temperature. When the junction temperature exceeds 140°C, power switch turns off. When the junction temperature falls below the thermal recovery temperature, approximately 120°C, the device keeps power switch off for AW35020, and auto-recovery after 130ms for AW35020A.

Output Discharge

A discharge resistor is connected to the OUT terminal when power switch turns off. The discharge resistor dissipates stored charge on OUT. The pull-down capability decreases as V_{IN} decreases.

PCB LAYOUT CONSIDERATION

To obtain the optimal performance of AW35020/AW35020A, PCB layout should be considered carefully. Here are some guidelines:

1. All peripheral devices should be as close as possible to the chip, C_{IN} , C_{OUT} , C_{SS} should be close to IN, OUT, SS pins respectively. Besides the metal traces of them should be short and wide.
2. Place R_1 , R_2 , R_3 as close as OVP. The traces routing the RILIM resistor to the device must be as short as possible to reduce parasitic effects on the current limit accuracy.
3. IN, OUT support 3A current, the connection lines should be as wide as possible.
4. Connect the IN and OUT PADS to a large IN and OUT plane respectively to achieve better thermal performance.

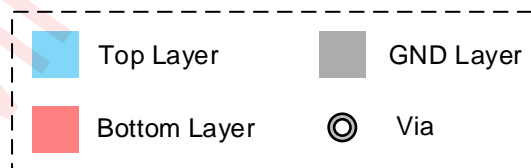
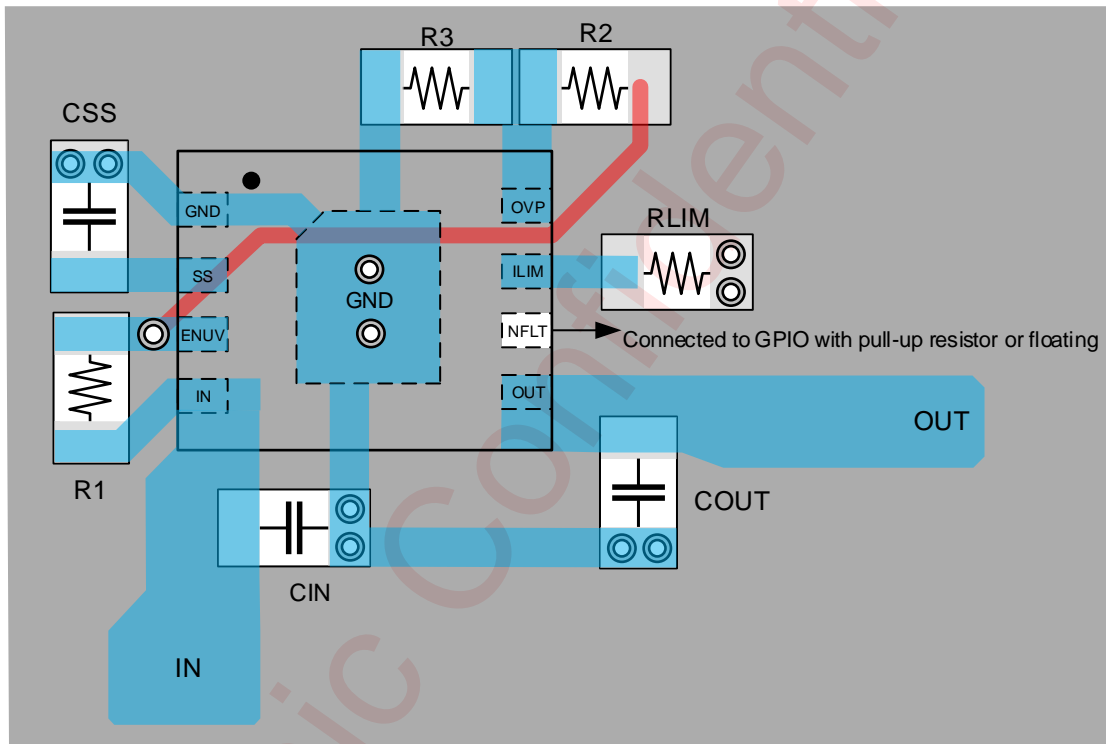
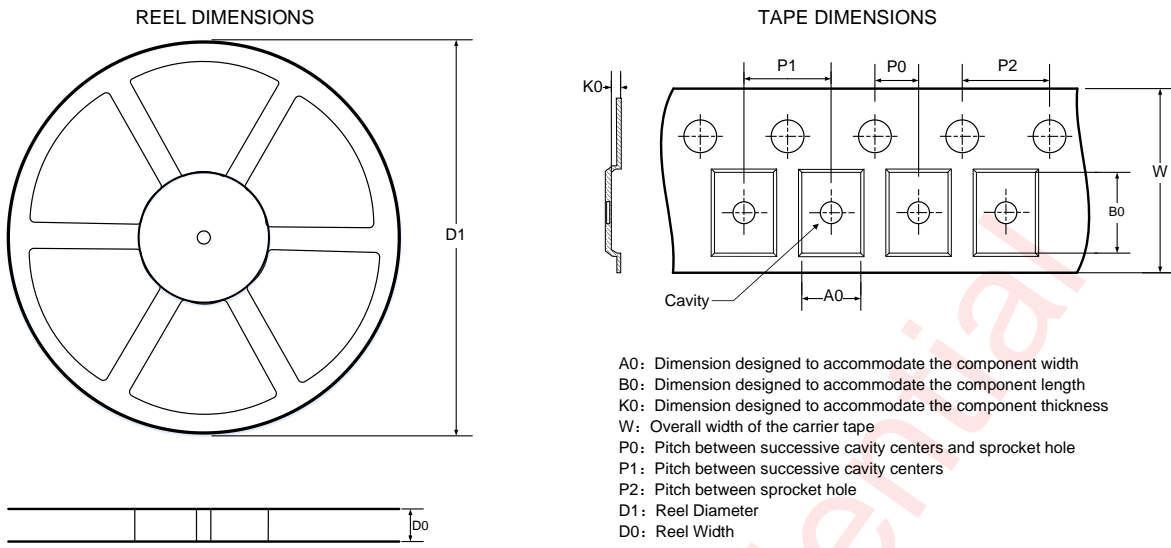
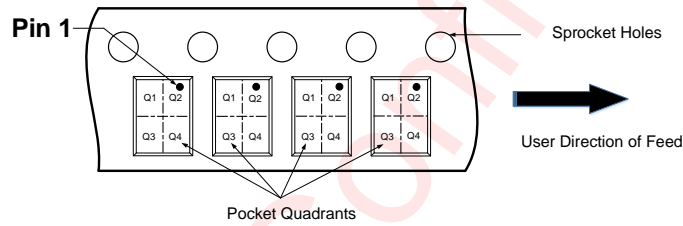

Figure 24 External Components Placements and PCB Layout Example

TAPE AND REEL INFORMATION



QUADRANT ASSIGNMENTS FOR PIN 1 ORIENTATION IN TAPE



Note: The above picture is for reference only. Please refer to the value in the table below for the actual size

DIMENSIONS AND PIN1 ORIENTATION

D1 (mm)	D0 (mm)	A0 (mm)	B0 (mm)	K0 (mm)	P0 (mm)	P1 (mm)	P2 (mm)	W (mm)	Pin1 Quadrant
178	8.4	2.3	3.3	1	2	4	4	8	Q2

All dimensions are nominal

PACKAGE DESCRIPTION

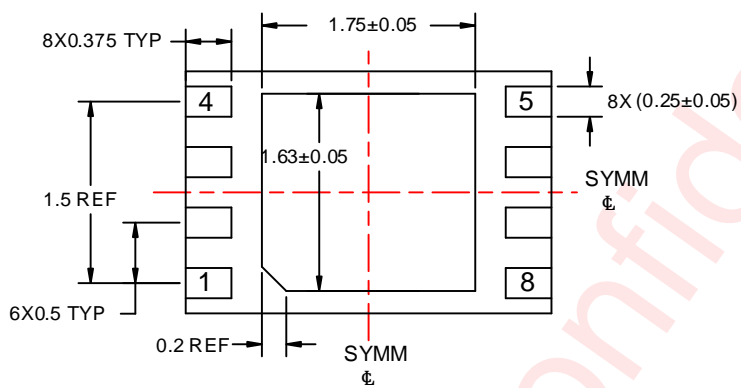
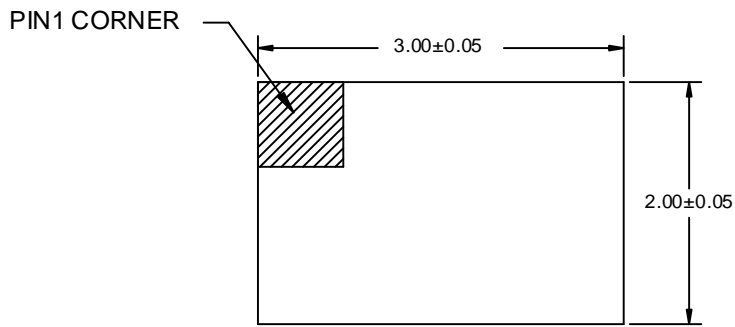

BOTTOM VIEW

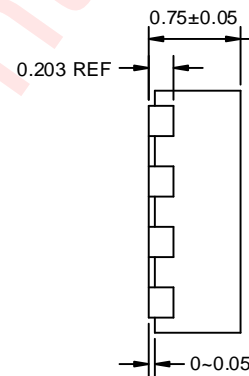

SIDE VIEW

Unit: mm

LAND PATTERN DATA

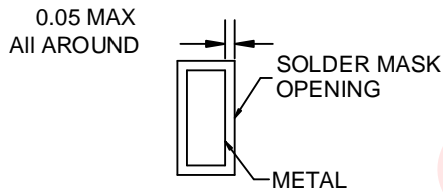
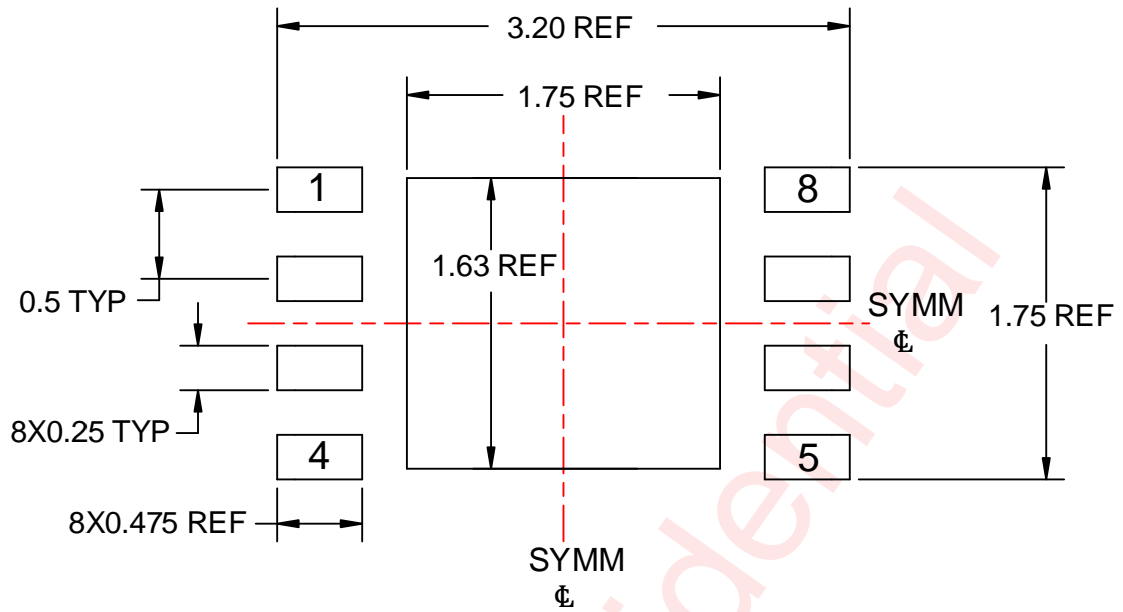

NON SOLDER MASK DEFINED

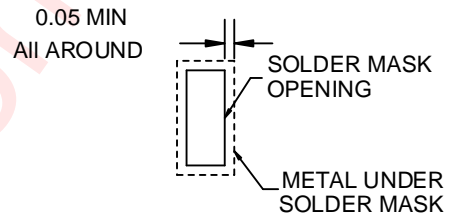

SOLDER MASK DEFINED

Unit: mm

REVISION HISTORY

Version	Date	Change Record
V1.0	Jan. 2021	First version
V1.1	Nov. 2021	<ol style="list-style-type: none"> 1. Change Ron up-limit 80mΩ to 70mΩ 2. Update Figure.19 3. Add V_{OVp} formula 4. Update short function description 5. Soft-start description add minimum t_{ss} 6. Tape and Reel changed from 4500units to 3000units 7. Update description of NFLT 8. Update timing diagram
V1.2	Dec. 2021	<ol style="list-style-type: none"> 1. Update ILIM value 2. Update ILIM formula 3. Update curve of ILIM&TEMP 4. Update curve of ILIM&R 5. Update t_{ss} 6. Modify description of
V1.3	May 2022	<ol style="list-style-type: none"> 1. Input voltage range update from 24V to 7V on page1 2. Update package thickness from 0.75um to 0.75mm on page1 3. Figure 1 add 100k pull-up resistor on NFLT on page1 4. Update PIN definition and a dd thermal pad on page2 5. Update function block diagram, add current limit, soft start and fast-trip principle design on page3 6. Update typical application circuits and description on page 4 7. Update absolute maximum ratings, OUT up limit changes from 28V to 7V on page 5 8. Update recommended operating conditions, Max spec of V_{IN}, V_{OUT}, V_{NFLT}, V_{ENUV}, V_{OVp} changes from 24V to 7V, and add R_{LIM}, C_{IN}, C_{OUT} spec on page 5 9. Electrical characteristics update: <ol style="list-style-type: none"> 1) V_{OVPR} spec changed from (1.33,1.46) to (1.36,1.42) 2) V_{OVPF} spec changed from (1.27,1.39) to (1.29,1.35) 3) I_{OVp} spec changed from (*,0.5) to (-0.1,0.1) 4) V_{ENUVR} spec changed from (1.33,1.46) to (1.35,1.42) 5) V_{ENUVF} spec changed from (1.27,1.39) to (1.29,1.35) 6) I_{ENUV} spec changed from (*,0.5) to (-0.1,0.1) 7) update Ron test condition, I_{OUT}=1A changed to I_{OUT}=200mA, and add Ron with I_{OUT}=350mA 8) add I_{SNK_OUT} 9) update I_{LIMB} spec from (4,6) to (4.5, 5.5) 10) I_{LIM} only keeps R_{LIM}=50K and R_{LIM}=200K 11) Delete I_{FAST-TRIP} and V_{LIM_OPEN} 12) Add T_{SDNHYS} 13) Update t_{ss} test condition and typical Value 14) Update electrical characteristics test conditions. 10. Update functional description from page 12 to page13 11. Update PCB layout consideration description on page 14
V1.4	May 2022	<ol style="list-style-type: none"> 1. Update I_{Q_OFF} spec on page 6, and update figure 5 on page 8 2. Update description of soft-start on page 12 3. Add AW35020A description in corresponding position
V1.5	July 2022	<ol style="list-style-type: none"> 1. VIN maximum operation voltage change from 7V to 24V. 2. I_{LIMIT_ST} update to about 50%*ILIM and update ILIM accuracy.

		3. Update Figure 14 and Figure 15
V1.6	September 2022	1. Operating free-air up-limit temperature is updated from 85°C to 105°C
V1.7	October 2022	1. Maximum operation voltage is changed from 24V to 7V
V1.8	Nov. 2023	Update TEST CONDITION and typical values for I_{SNK_OUT} (Page 7)

awinic Confidential

DISCLAIMER

Information in this document is believed to be accurate and reliable. However, Shanghai AWINIC Technology Co., Ltd (AWINIC Technology) does not give any representations or warranties, expressed or implied, as to the accuracy or completeness of such information and shall have no liability for the consequences of use of such information.

AWINIC Technology reserves the right to make changes to information published in this document, including without limitation specifications and product descriptions, at any time and without notice. Customers shall obtain the latest relevant information before placing orders and shall verify that such information is current and complete. This document supersedes and replaces all information supplied prior to the publication hereof.

AWINIC Technology products are not designed, authorized or warranted to be suitable for use in medical, military, aircraft, space or life support equipment, nor in applications where failure or malfunction of an AWINIC Technology product can reasonably be expected to result in personal injury, death or severe property or environmental damage. AWINIC Technology accepts no liability for inclusion and/or use of AWINIC Technology products in such equipment or applications and therefore such inclusion and/or use is at the customer's own risk.

Applications that are described herein for any of these products are for illustrative purposes only. AWINIC Technology makes no representation or warranty that such applications will be suitable for the specified use without further testing or modification.

All products are sold subject to the general terms and conditions of commercial sale supplied at the time of order acknowledgement.

Nothing in this document may be interpreted or construed as an offer to sell products that is open for acceptance or the grant, conveyance or implication of any license under any copyrights, patents or other industrial or intellectual property rights.

Reproduction of AWINIC information in AWINIC data books or data sheets is permissible only if reproduction is without alteration and is accompanied by all associated warranties, conditions, limitations, and notices. AWINIC is not responsible or liable for such altered documentation. Information of third parties may be subject to additional restrictions.

Resale of AWINIC components or services with statements different from or beyond the parameters stated by AWINIC for that component or service voids all express and any implied warranties for the associated AWINIC component or service and is an unfair and deceptive business practice. AWINIC is not responsible or liable for any such statements.