



4Mb Ultra-Low Power Asynchronous CMOS SRAM

256K × 16 bit

Overview

The N04L63W2A is an integrated memory device containing a 4 Mbit Static Random Access Memory organized as 262,144 words by 16 bits. The device is designed and fabricated using ON Semiconductor's advanced CMOS technology to provide both high-speed performance and ultra-low power. The device operates with two chip enable ($\overline{CE1}$ and $\overline{CE2}$) controls and output enable (\overline{OE}) to allow for easy memory expansion. Byte controls (\overline{UB} and \overline{LB}) allow the upper and lower bytes to be accessed independently and can also be used to deselect the device. The N04L63W2A is optimal for various applications where low-power is critical such as battery backup and hand-held devices. The device can operate over a very wide temperature range of -40°C to +85°C and is available in JEDEC standard packages compatible with other standard 256Kb x 16 SRAMs

Features

- **Single Wide Power Supply Range**
2.3 to 3.6 Volts
- **Very low standby current**
4.0µA at 3.0V (Typical)
- **Very low operating current**
2.0mA at 3.0V and 1µs (Typical)
- **Very low Page Mode operating current**
0.8mA at 3.0V and 1µs (Typical)
- **Simple memory control**
Dual Chip Enables ($\overline{CE1}$ and $\overline{CE2}$)
Output Enable (\overline{OE}) for memory expansion
- **Low voltage data retention**
 $V_{CC} = 1.8V$
- **Very fast output enable access time**
25ns \overline{OE} access time
- **Automatic power down to standby mode**
- **TTL compatible three-state output driver**
- **Compact space saving BGA package available**

Product Family

Part Number	Package Type	Operating Temperature	Power Supply (Vcc)	Speed Options	Standby Current (I _{SB}), Typical	Operating Current (I _{CC}), Typical
N04L63W2AB	48 - BGA	-40°C to +85°C	2.3V - 3.6V	70ns @ 2.7V 55ns @ 2.7V	4 µA	2 mA @ 1MHz
N04L63W2AT	44 - TSOP II					
N04L63W2AB2	48 - BGA Green					
N04L63W2AT2	44 - TSOP II Green					

Pin Configuration

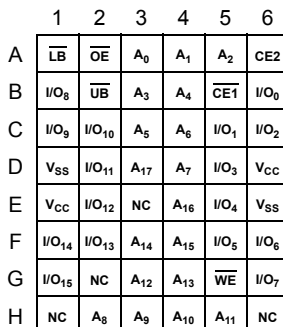
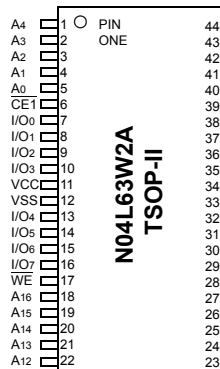

48 Pin BGA (top)
6 x 8 mm

Pin Descriptions

Pin Name	Pin Function
A ₀ -A ₁₇	Address Inputs
\overline{WE}	Write Enable Input
$\overline{CE1}$, $\overline{CE2}$	Chip Enable Input
\overline{OE}	Output Enable Input
\overline{LB}	Lower Byte Enable Input
\overline{UB}	Upper Byte Enable Input
I/O ₀ -I/O ₁₅	Data Inputs/Outputs
V _{CC}	Power
V _{SS}	Ground
NC	Not Connected

N04L63W2A

Functional Block Diagram

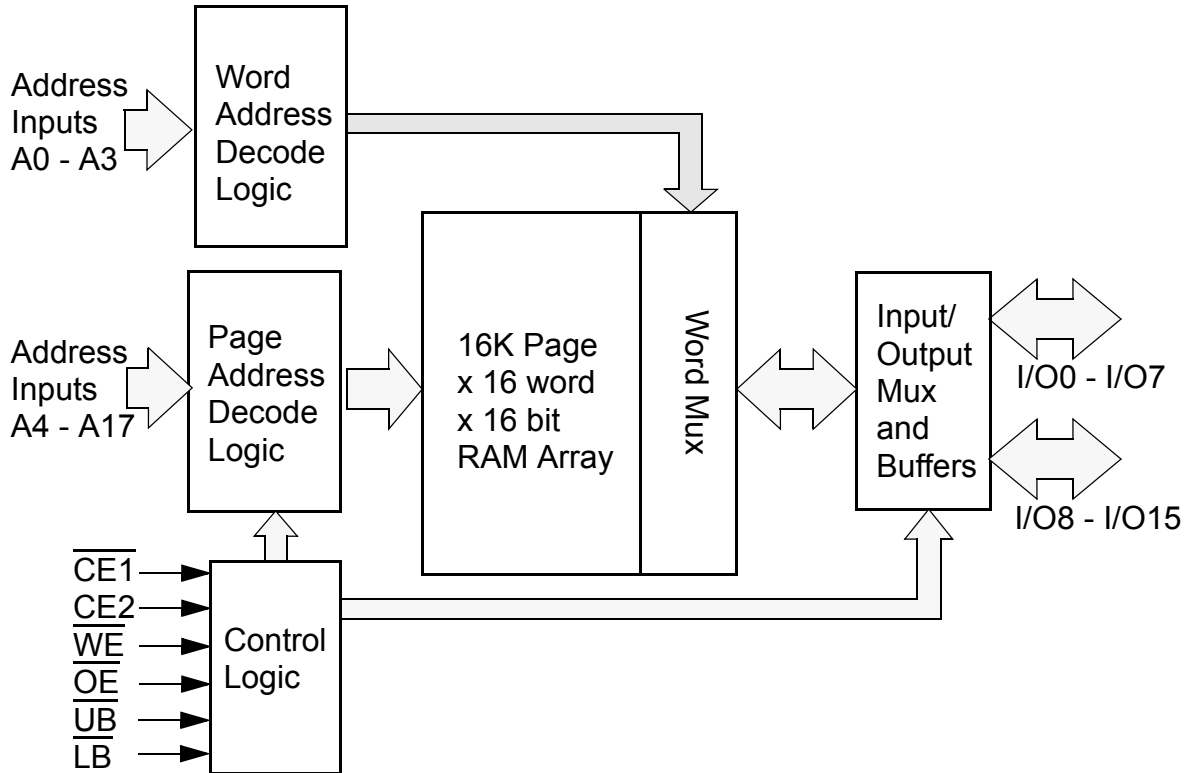

Functional Description

$\overline{CE1}$	$\overline{CE2}$	\overline{WE}	\overline{OE}	\overline{UB}	\overline{LB}	$I/O_0 - I/O_{15}^1$	MODE	POWER
H	X	X	X	X	X	High Z	Standby ²	Standby
X	L	X	X	X	X	High Z	Standby ²	Standby
L	H	X	X	H	H	High Z	Standby	Standby
L	H	L	X ³	L ¹	L ¹	Data In	Write ³	Active
L	H	H	L	L ¹	L ¹	Data Out	Read	Active
L	H	H	H	L ¹	L ¹	High Z	Active	Active

1. When \overline{UB} and \overline{LB} are in select mode (low), $I/O_0 - I/O_{15}$ are affected as shown. When \overline{LB} only is in the select mode only $I/O_0 - I/O_7$ are affected as shown. When \overline{UB} is in the select mode only $I/O_8 - I/O_{15}$ are affected as shown.

2. When the device is in standby mode, control inputs (\overline{WE} , \overline{OE} , \overline{UB} , and \overline{LB}), address inputs and data input/outputs are internally isolated from any external influence and disabled from exerting any influence externally.

3. When \overline{WE} is invoked, the \overline{OE} input is internally disabled and has no effect on the circuit.

Capacitance¹

Item	Symbol	Test Condition	Min	Max	Unit
Input Capacitance	C_{IN}	$V_{IN} = 0V, f = 1 \text{ MHz}, T_A = 25^\circ\text{C}$		8	pF
I/O Capacitance	$C_{I/O}$	$V_{IN} = 0V, f = 1 \text{ MHz}, T_A = 25^\circ\text{C}$		8	pF

1. These parameters are verified in device characterization and are not 100% tested

N04L63W2A

Absolute Maximum Ratings¹

Item	Symbol	Rating	Unit
Voltage on any pin relative to V _{SS}	V _{IN,OUT}	-0.3 to V _{CC} +0.3	V
Voltage on V _{CC} Supply Relative to V _{SS}	V _{CC}	-0.3 to 4.5	V
Power Dissipation	P _D	500	mW
Storage Temperature	T _{STG}	-40 to 125	°C
Operating Temperature	T _A	-40 to +85	°C
Soldering Temperature and Time	T _{SOLDER}	260°C, 10sec	°C

1. Stresses greater than those listed above may cause permanent damage to the device. This is a stress rating only and functional operation of the device at these or any other conditions above those indicated in the operating section of this specification is not implied. Exposure to absolute maximum rating conditions for extended periods may affect reliability.

Operating Characteristics (Over Specified Temperature Range)

Item	Symbol	Test Conditions	Min.	Typ ¹	Max	Unit
Supply Voltage	V _{CC}		2.3	3.0	3.6	V
Data Retention Voltage	V _{DR}	Chip Disabled ³	1.8		3.6	V
Input High Voltage	V _{IH}		1.8		V _{CC} +0.3	V
Input Low Voltage	V _{IL}		-0.3		0.6	V
Output High Voltage	V _{OH}	I _{OH} = 0.2mA	V _{CC} -0.2			V
Output Low Voltage	V _{OL}	I _{OL} = -0.2mA			0.2	V
Input Leakage Current	I _{LI}	V _{IN} = 0 to V _{CC}			0.5	μA
Output Leakage Current	I _{LO}	\overline{OE} = V _{IH} or Chip Disabled			0.5	μA
Read/Write Operating Supply Current @ 1 μs Cycle Time ²	I _{CC1}	V _{CC} =3.6 V, V _{IN} =V _{IH} or V _{IL} Chip Enabled, I _{OUT} = 0		2.0	3.0	mA
Read/Write Operating Supply Current @ 70 ns Cycle Time ²	I _{CC2}	V _{CC} =3.6 V, V _{IN} =V _{IH} or V _{IL} Chip Enabled, I _{OUT} = 0		10.0	16.0	mA
Page Mode Operating Supply Current @ 70ns Cycle Time ² (Refer to Power Savings with Page Mode Operation diagram)	I _{CC3}	V _{CC} =3.6 V, V _{IN} =V _{IH} or V _{IL} Chip Enabled, I _{OUT} = 0		4.0		mA
Read/Write Quiescent Operating Supply Current ³	I _{CC4}	V _{CC} =3.6 V, V _{IN} =V _{IH} or V _{IL} Chip Enabled, I _{OUT} = 0, f = 0			2.0	mA
Maximum Standby Current ³	I _{SB1}	V _{IN} = V _{CC} or 0V Chip Disabled t _A = 85°C, V _{CC} = 3.6 V		4.0	20.0	μA
Maximum Data Retention Current ³	I _{DR}	V _{CC} = 1.8V, V _{IN} = V _{CC} or 0 Chip Disabled, t _A = 85°C			10	μA

1. Typical values are measured at V_{CC}=V_{CC} Typ., T_A=25°C and not 100% tested.

2. This parameter is specified with the outputs disabled to avoid external loading effects. The user must add current required to drive output capacitance expected in the actual system.

3. This device assumes a standby mode if the chip is disabled ($\overline{CE1}$ high or CE2 low). In order to achieve low standby current all inputs must be within 0.2 volts of either V_{CC} or V_{SS}.

N04L63W2A

Power Savings with Page Mode Operation ($\overline{WE} = V_{IH}$)

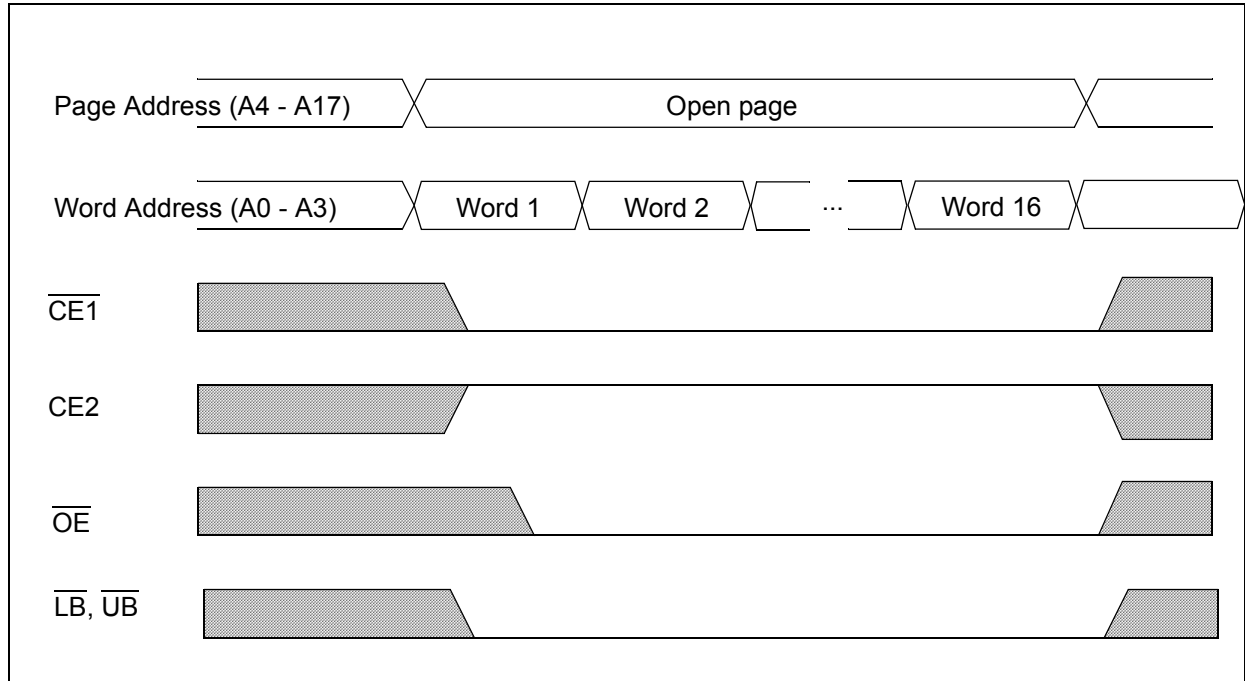

Note: Page mode operation is a method of addressing the SRAM to save operating current. The internal organization of the SRAM is optimized to allow this unique operating mode to be used as a valuable power saving feature.

The only thing that needs to be done is to address the SRAM in a manner that the internal page is left open and 16-bit words of data are read from the open page. By treating addresses A0-A3 as the least significant bits and addressing the 16 words within the open page, power is reduced to the page mode value which is considerably lower than standard operating currents for low power SRAMs.

N04L63W2A

Timing Test Conditions

Item	
Input Pulse Level	0.1V _{CC} to 0.9 V _{CC}
Input Rise and Fall Time	5ns
Input and Output Timing Reference Levels	0.5 V _{CC}
Output Load	CL = 30pF
Operating Temperature	-40 to +85 °C

Timing

Item	Symbol	-70				-55		Units
		2.3 - 2.65 V		2.7 - 3.6 V		2.7 - 3.6 V		
		Min.	Max.	Min.	Max.	Min.	Max.	
Read Cycle Time	t _{RC}	85		70		55		ns
Address Access Time	t _{AA}		85		70		55	ns
Chip Enable to Valid Output	t _{CO}		85		70		55	ns
Output Enable to Valid Output	t _{OE}		30		25		25	ns
Byte Select to Valid Output	t _{LB} , t _{UB}		85		70		55	ns
Chip Enable to Low-Z output	t _{LZ}	10		10		10		ns
Output Enable to Low-Z Output	t _{OLZ}	5		5		5		ns
Byte Select to Low-Z Output	t _{BZ}	10		10		10		ns
Chip Disable to High-Z Output	t _{HZ}	0	20	0	20	0	20	ns
Output Disable to High-Z Output	t _{OHZ}	0	20	0	20	0	20	ns
Byte Select Disable to High-Z Output	t _{BHZ}	0	20	0	20	0	20	ns
Output Hold from Address Change	t _{OH}	10		10		10		ns
Write Cycle Time	t _{WC}	85		70		55		ns
Chip Enable to End of Write	t _{CW}	50		50		45		ns
Address Valid to End of Write	t _{AW}	50		50		45		ns
Byte Select to End of Write	t _{BW}	50		50		45		ns
Write Pulse Width	t _{WP}	40		40		40		ns
Address Setup Time	t _{AS}	0		0		0		ns
Write Recovery Time	t _{WR}	0		0		0		ns
Write to High-Z Output	t _{WHZ}		20		20		20	ns
Data to Write Time Overlap	t _{DW}	40		40		40		ns
Data Hold from Write Time	t _{DH}	0		0		0		ns
End Write to Low-Z Output	t _{OW}	5		5		5		ns

N04L63W2A

Timing Waveform of Write Cycle ($\overline{\text{WE}}$ control)

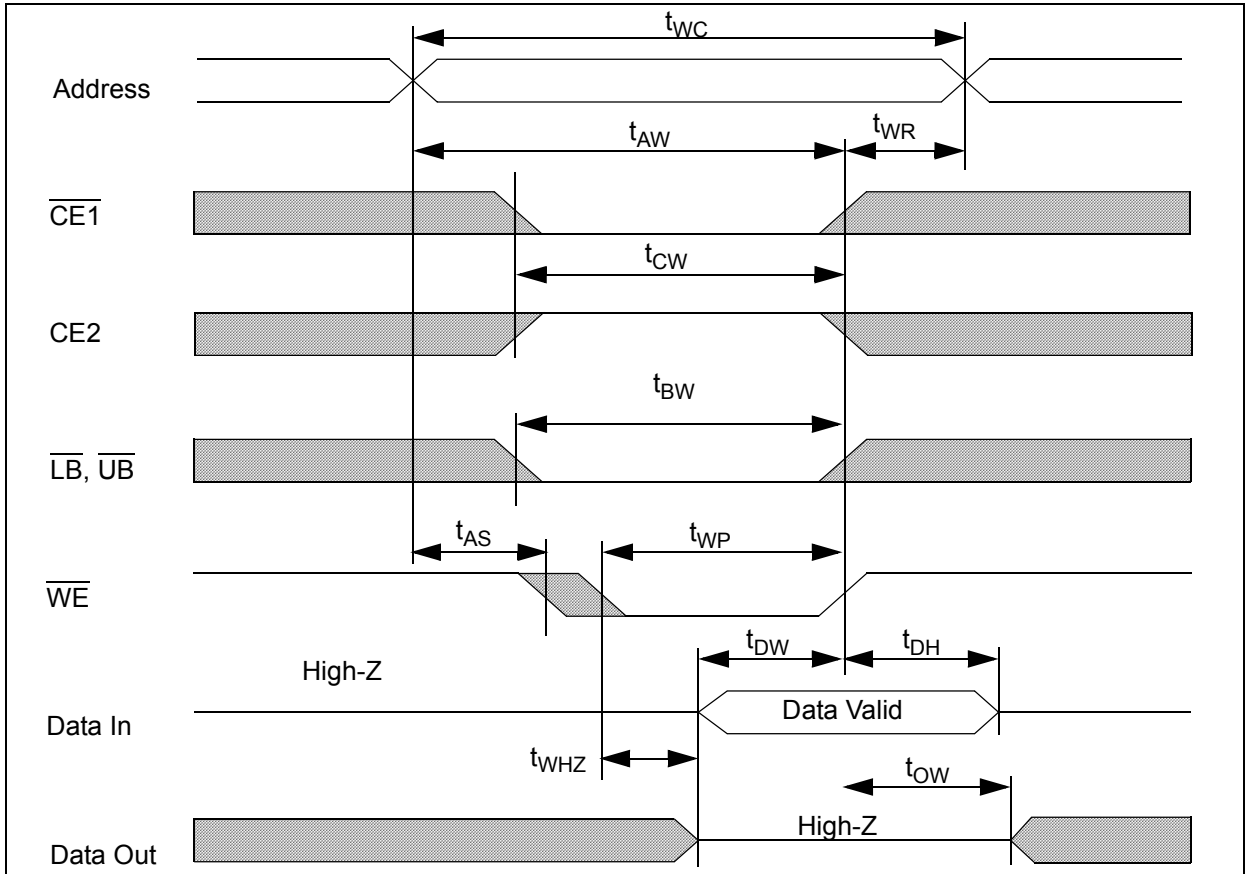

Timing Waveform of Write Cycle ($\overline{\text{CE1}}$ Control)

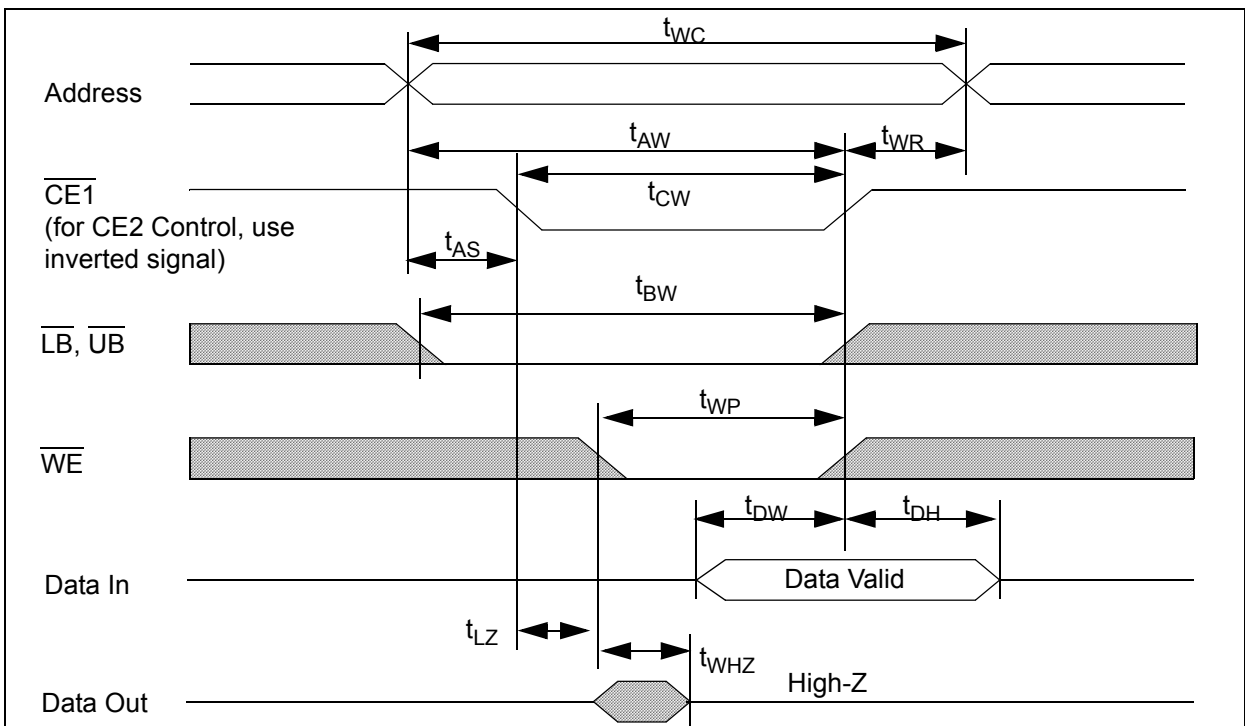

N04L63W2A

44-Lead TSOP II Package (T44)

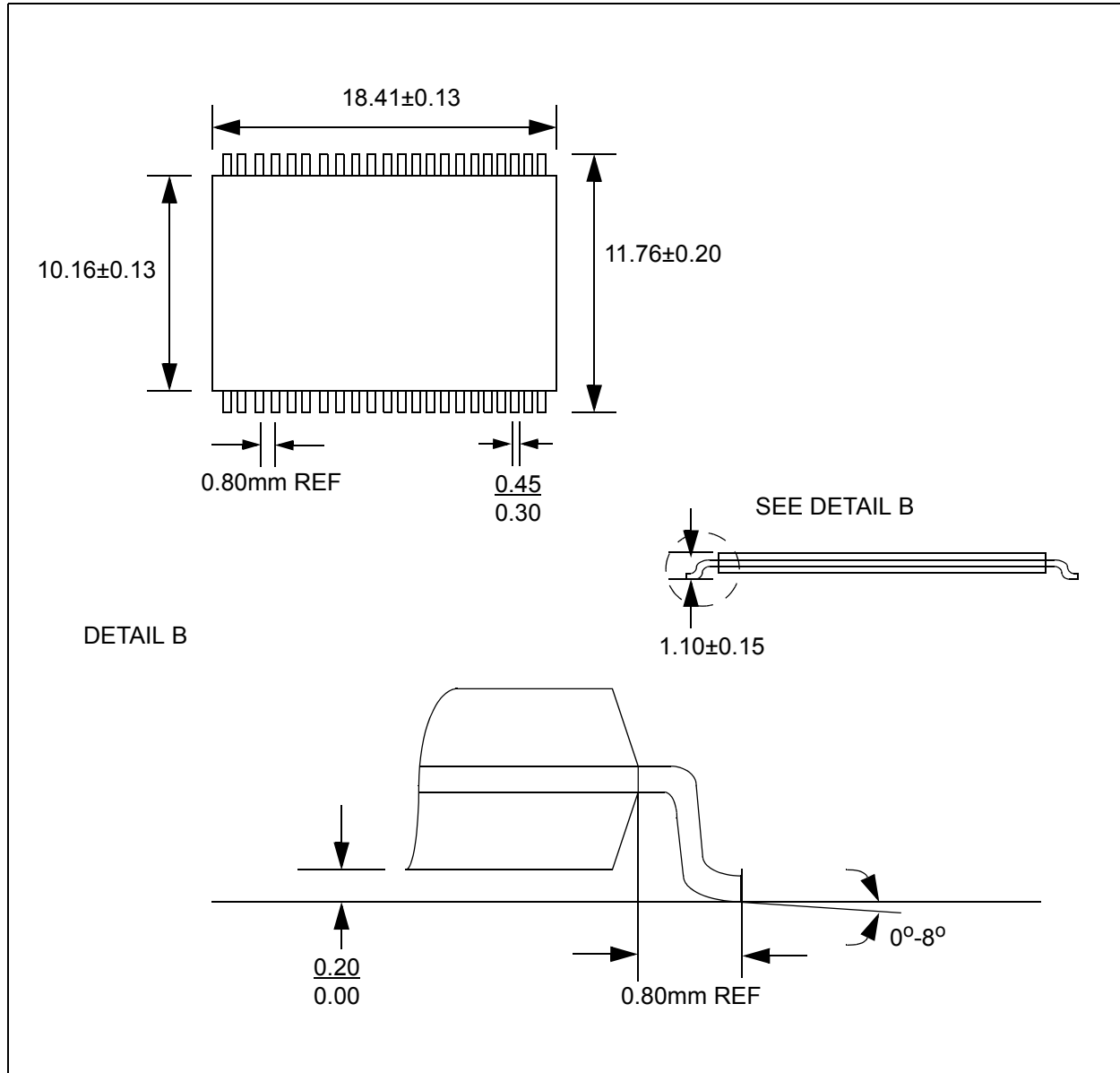

Note:

1. All dimensions in inches (Millimeters)
2. Package dimensions exclude molding flash

N04L63W2A

Ball Grid Array Package

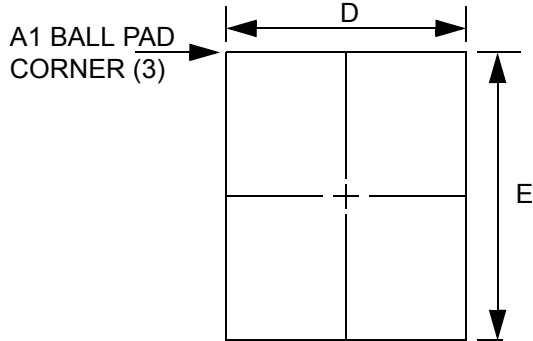

TOP VIEW

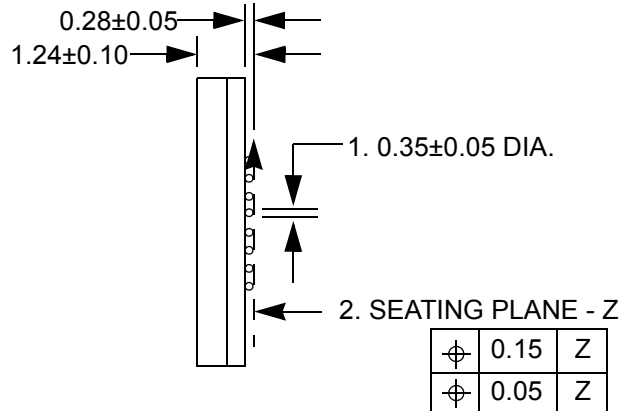

SIDE VIEW

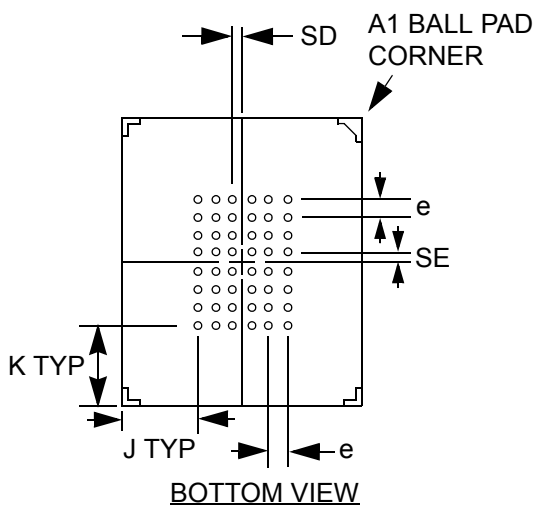

1. DIMENSION IS MEASURED AT THE MAXIMUM SOLDER BALL DIAMETER. PARALLEL TO PRIMARY Z.

2. PRIMARY DATUM Z AND SEATING PLANE ARE DEFINED BY THE SPHERICAL CROWNS OF THE SOLDER BALLS.

3. A1 BALL PAD CORNER I.D. TO BE MARKED BY INK.

Dimensions (mm)

D	E	e = 0.75				BALL MATRIX TYPE
		SD	SE	J	K	
6±0.10	8±0.10	0.375	0.375	1.125	1.375	FULL

N04L63W2A

Ordering Information

Part Number	Package	Shipping Method
N04L63W2AT7I	Leaded 44-TSOP II	Tray
N04L63W2AT27I	Green 44-TSOP II (RoHS Compliant)	Tray
N04L63W2AB7I	Leaded 48-BGA	Tray
N04L63W2AB27I	Green 48-BGA (RoHS Compliant)	Tray
N04L63W2AT7IT	Leaded 44-TSOP II	Tape & Reel
N04L63W2AT27IT	Green 44-TSOP II (RoHS Compliant)	Tape & Reel
N04L63W2AB7IT	Leaded 48-BGA	Tape & Reel
N04L63W2AB27IT	Green 48-BGA (RoHS Compliant)	Tape & Reel

Please contact factory for 55ns speed grade

Revision History

Revision	Date	Change Description
A	Jan. 2001	Initial Preliminary Release
B	Dec. 2001	Part number change from EM256J16, modified Overview and Features, added Page Mode Operation diagram, revised Operating Characteristics table, Package diagram, Functional Description table and Ordering Information diagram
C	Nov. 2002	Replaced Isb and Icc on Product Family table with typical values
D	February 2003	Added 55ns sort
E	August 2004	Removed 55ns sort
F	Oct 2004	Added Pb-Free and Green Package Option
G	Nov. 2005	Removed Pb-Free Pkg., added Green Pkg and RoHS Compliant was added
H	September 2006	Converted to AMI Semiconductor
I	October 2007	Added 55ns performance sort
10	July 2008	Converted to ON Semiconductor and new part numbers

ON Semiconductor and  are registered trademarks of Semiconductor Components Industries, LLC (SCILLC). SCILLC reserves the right to make changes without further notice to any products herein. SCILLC makes no warranty, representation or guarantee regarding the suitability of its products for any particular purpose, nor does SCILLC assume any liability arising out of the application or use of any product or circuit, and specifically disclaims any and all liability, including without limitation special, consequential or incidental damages. "Typical" parameters which may be provided in SCILLC data sheets and/or specifications can and do vary in different applications and actual performance may vary over time. All operating parameters, including "Typicals" must be validated for each customer application by customer's technical experts. SCILLC does not convey any license under its patent rights nor the rights of others. SCILLC products are not designed, intended, or authorized for use as components in systems intended for surgical implant into the body, or other applications intended to support or sustain life, or for any other application in which the failure of the SCILLC product could create a situation where personal injury or death may occur. Should Buyer purchase or use SCILLC products for any such unintended or unauthorized application, Buyer shall indemnify and hold SCILLC and its officers, employees, subsidiaries, affiliates, and distributors harmless against all claims, costs, damages, and expenses, and reasonable attorney fees arising out of, directly or indirectly, any claim of personal injury or death associated with such unintended or unauthorized use, even if such claim alleges that SCILLC was negligent regarding the design or manufacture of the part. SCILLC is an Equal Opportunity/Affirmative Action Employer. This literature is subject to all applicable copyright laws and is not for resale in any manner.

PUBLICATION ORDERING INFORMATION

LITERATURE FULFILLMENT:

Literature Distribution Center for ON Semiconductor
PO Box 5163, Denver, Colorado 80217 USA
Phone: 303-675-2175 or 800-344-3860 Toll Free USA/Canada
Fax: 303-675-2176 or 800-344-3867 Toll Free USA/Canada
Email: orderlit@onsemi.com

N. American Technical Support: 800-282-9855 Toll Free USA/Canada
Europe, Middle East & Africa Technical Support: Phone 421-33-790-2910
Japan Customer Focus Center: Phone 81-3-5773-3850

ON Semiconductor Website: www.onsemi.com

Order Literature: <http://www.onsemi.com/orderlit>

For additional information, please contact your local Sales Representative