

ZCT25N12

limit switch body ZCT - compact - 1NO+1NC -
slow-break - 1/2"NPT

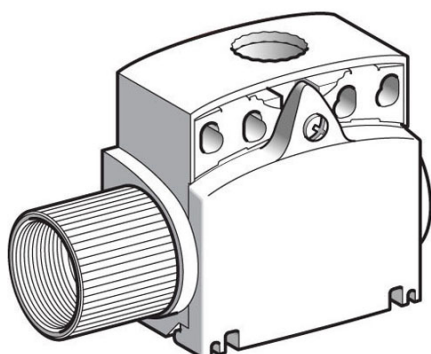

Main

Range of product	OsiSense XC
Series name	Standard format
Product or component type	Limit switch body
Device short name	ZCT
Body type	Fixed
Product compatibility	XCKT
Associated head	ZCE01 ZCE02 ZCE06 ZCE07 ZCE08 ZCE09 ZCE10 ZCE11 ZCE13 ZCE14 ZCE21 ZCE24 ZCE27 ZCE28 ZCE29 ZCE62 ZCE63 ZCE64 ZCE65 ZCE66 ZCE67 ZCEH0 ZCEH2
Electrical connection	Screw-clamp terminals , clamping capacity: 1 x 0.5...2 x 2.5 mm ²
Cable entry	2 entries tapped for 1/2" NPT adaptor , cable outer diameter: 4...8 mm
Number of poles	2
Contacts type and composition	1 NO + 1 NC
Contacts operation	Slow-break
Contacts material	Silver plated contacts
Positive opening	With

Complementary

Design	Compact
Body material	Plastic
Contacts insulation form	Zb
Minimum actuation speed	6 m/min
Contact code designation	B300 , AC-15 (U _e = 240 V , I _e = 1.5 A) conforming to EN/IEC 60947-5-1 appendix A R300 , DC-13 (U _e = 250 V , I _e = 0.1 A) conforming to EN/IEC 60947-5-1 appendix A
[Ui] rated insulation voltage	300 V conforming to UL 508 300 V conforming to CSA C22-2 No 14 500 V degree of pollution 3 conforming to IEC 60947-1
Resistance across terminals	< 25 mOhm conforming to IEC 60255-7 category 3
[Uimp] rated impulse withstand voltage	6 kV conforming to IEC 60947-1 6 kV conforming to IEC 60664
Short circuit protection	10 A by gG cartridge fuse

Electrical durability	5000000 cycles , DC-13 (Uc = 24 V), 13 W , load factor: 0.5 , operating rate: < 60 cyc/mn conforming to IEC 60947-5-1 appendix C 5000000 cycles , DC-13 (Uc = 48 V), 9 W , load factor: 0.5 , operating rate: < 60 cyc/mn conforming to IEC 60947-5-1 appendix C 5000000 cycles , DC-13 (Uc = 120 V), 7 W , load factor: 0.5 , operating rate: < 60 cyc/mn conforming to IEC 60947-5-1 appendix C
Width	58 mm
Height	51 mm
Depth	30 mm
Product weight	0.13 kg

Environment

Ambient air temperature for operation	-25...70 °C
Ambient air temperature for storage	-40...70 °C
RoHS EUR conformity date	4Q2009
RoHS EUR status	Will be compliant

Mouser Electronics

Authorized Distributor

Click to View Pricing, Inventory, Delivery & Lifecycle Information:

[Schneider Electric:](#)

[ZCT25N12](#)