

SECTION A-A

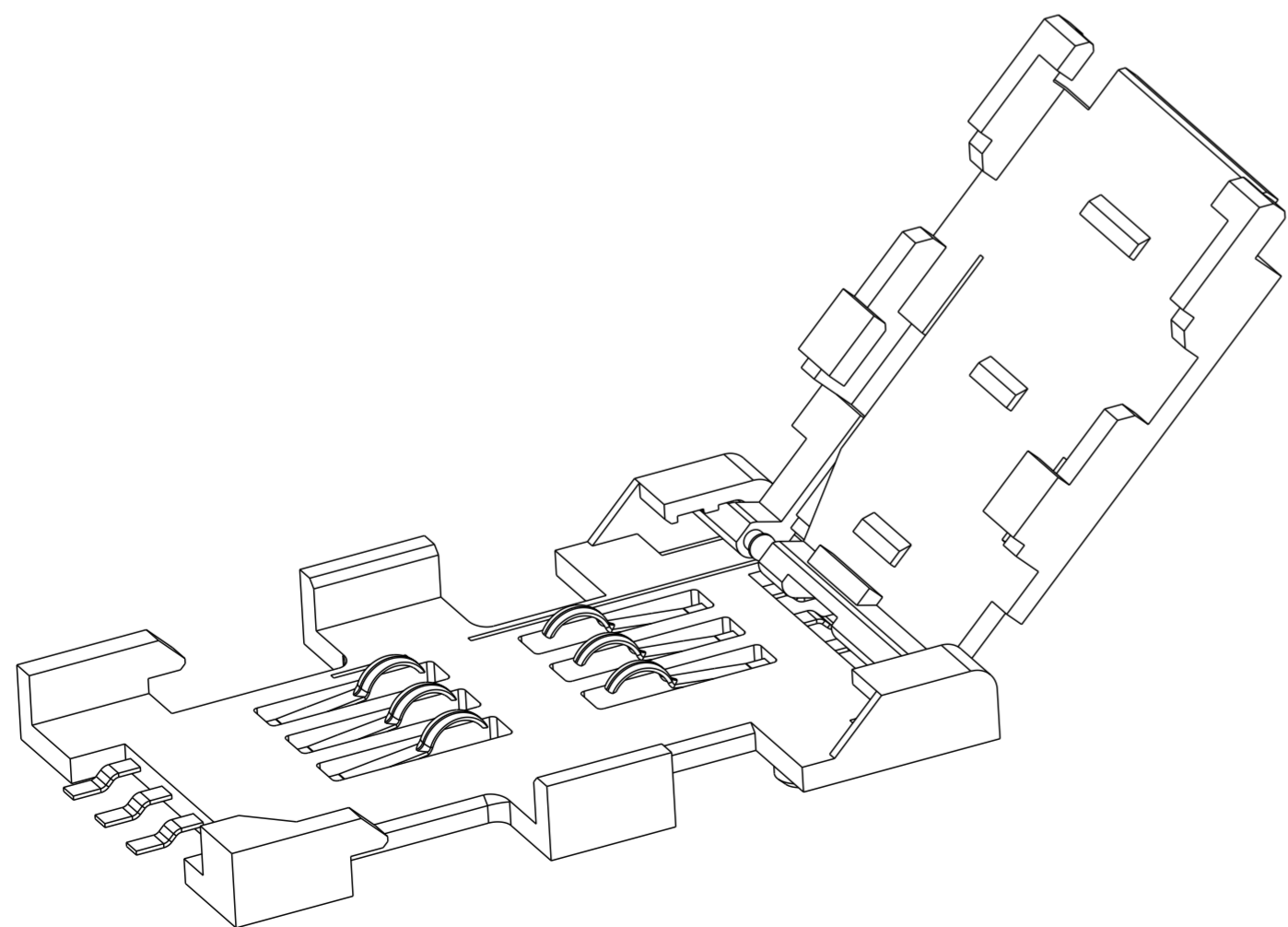
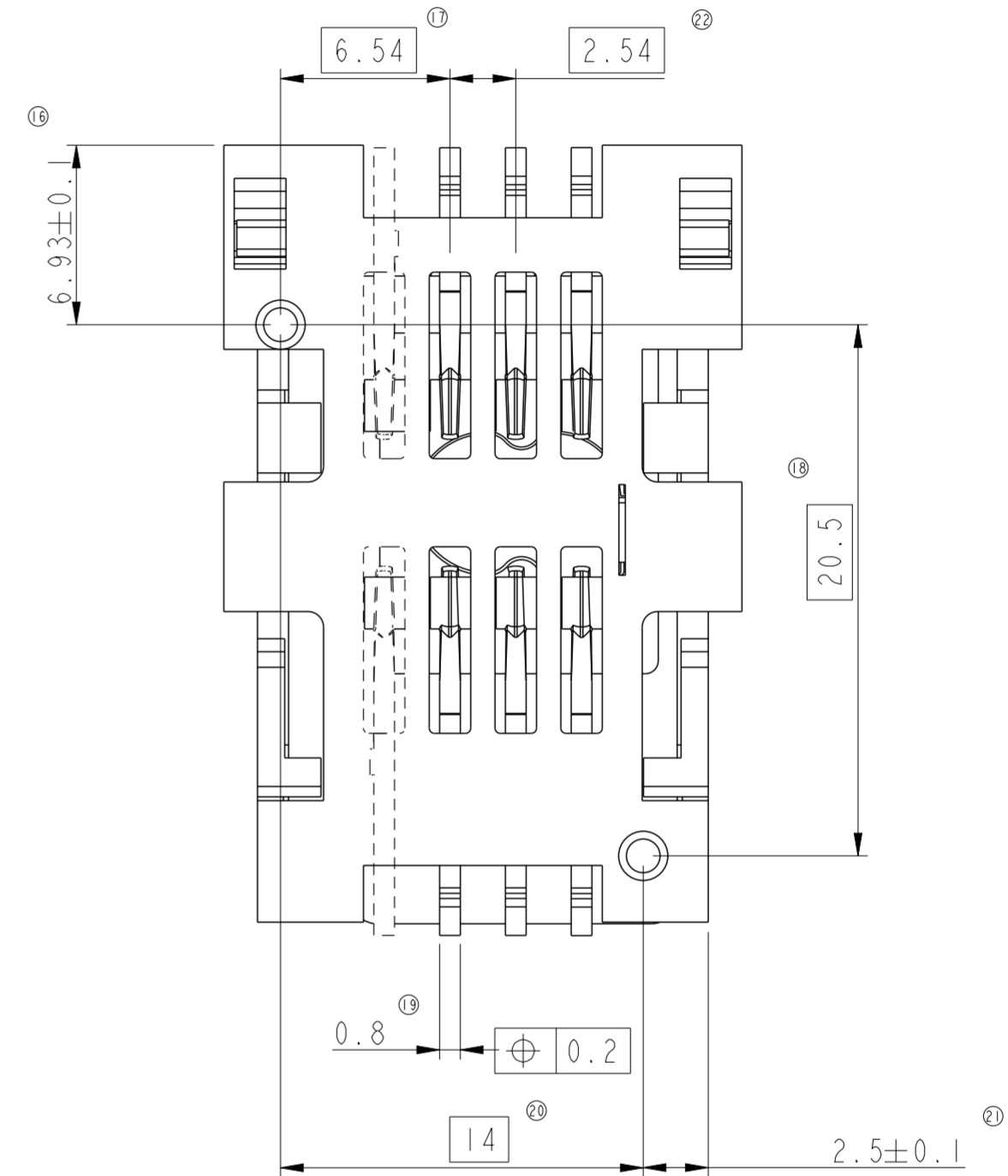
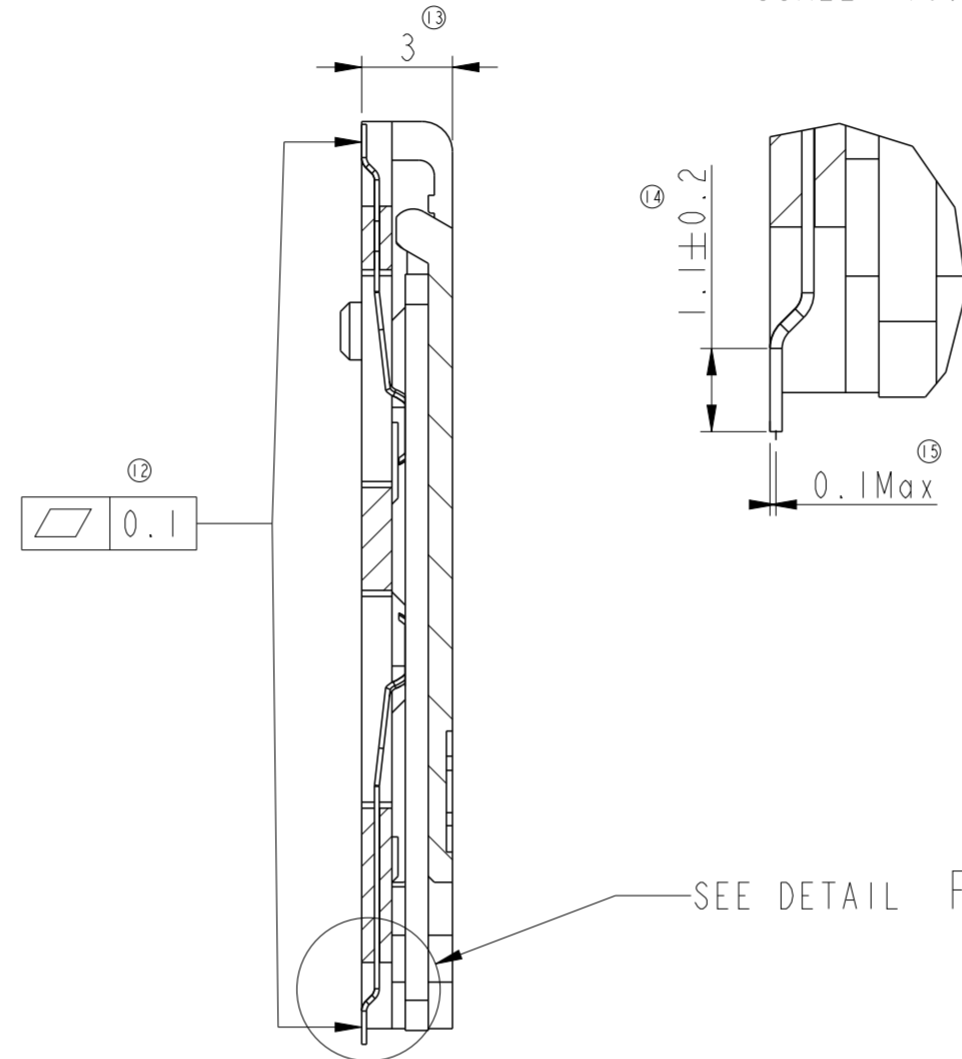

7X12S08XXX19LF

- LEAD FREE
- 5: DURABILITY 10,000 OPERATIONS
- 1: 6 CONTACTS
- 2: 8 CONTACTS
- 1: TAPE N REEL PACKAGING
- 3: TRAY PACKAGING

General Tolerances	
0 to 10mm:	±0.1mm
10 to 30mm:	±0.15mm
30 to 60mm:	±0.2mm
60 and more:	±0.3mm

spec ref	--	dr	P-Mathew Nebu	2012/05/09	projection	mm	size	A2	scale	4:1
tolerance std	ISO 406 ISO 1101	eng	P-Mathew Nebu	2013/08/08		mm	ecn no	ELX-15417-2		
surface	ISO 1302	chr	-	appr			K-Paul Biju	2013/08/20	product family	MOBILE I/O
				title ASSY FULL COVER without SPRING SIM S08			dwg no VRW11882	rev E		
		www.fci.com		cat. no.	see table	Product - Customer Draw	sheet 1 of 2			

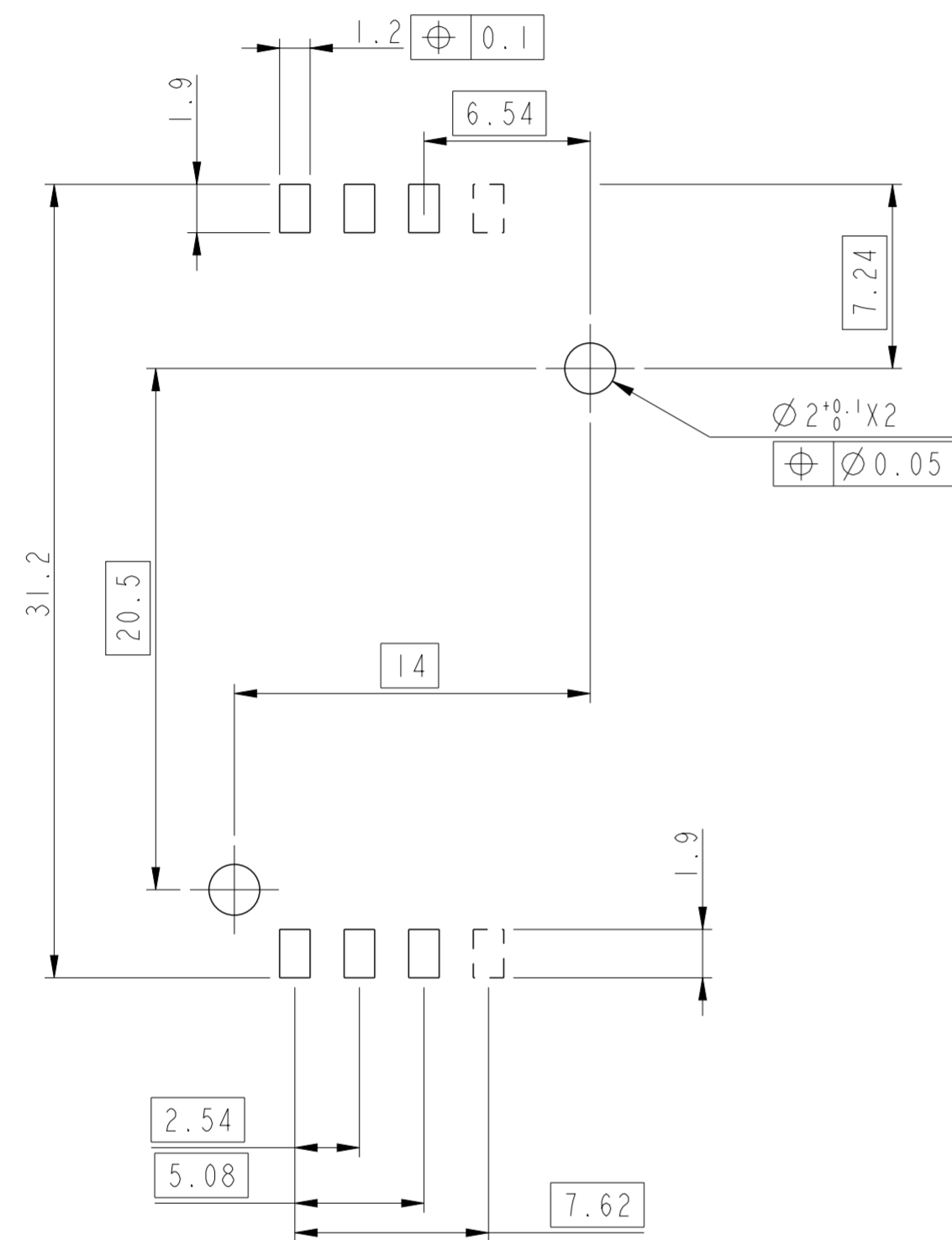

LAYOUT RECOMMENDED

NOTES:

MECHANICAL PROPERTIES:

Housing material: High Temp. Thermoplastic ,colour grey, UL94V0 rated

Contacts material: Copper Alloy

Plating:

Contact area: Au / Equivalent PdNi over Ni  
Solder area : Matte Tin over Ni on solder tails

For lead free plating:

Matte pure tin on solder tail in place of Tin/Lead  
Bare edge allowed

Durability: 10000 mating cycles

Contacts force : 0.5N Max at maximum deflection

LEAD FREE VERSION:

"This product meets European Union Directives and other country regulations as described in GS-47-0004"

The housing will withstand exposure to 260°C peak temperature for 10seconds in a convection reflow oven.

spec ref	--	dr	P-Mathew Nebu	2012/05/09	projection	mm	size	A2	scale	4:1	
tolerance std	ISO 406 ISO 1101	eng	P-Mathew Nebu	2013/08/08		mm	ecn no	ELX-15417-2	rel level	Released	
TOLERANCES UNLESS OTHERWISE SPECIFIED		chr	-	apppr							K-Paul Biju
surface	ISO 1302	linear	0.X	±		title ASSY FULL COVER without SPRING SIM S08	dwg no VRW11882	rev E	Product - Customer Drw		
		angular	0°	±°					cat. no.	SEE TABLE	sheet 2 of 2
									www.fci.com		