



## General Description

The LM321 brings performance and economy to low power systems. With a high unity gain frequency and a guaranteed  $0.4V/\mu s$  slew rate, the quiescent current is only  $430\mu A$ /amplifier (5V). The input common mode range includes ground and therefore the device is able to operate in single supply applications as well as in dual supply applications. It is also capable of comfortably driving large capacitive loads.

The LM321 is available in the SOT-23-5L package. Overall the LM321 is a low power, wide supply range performance op amp that can be designed into a wide range of applications at an economical price without sacrificing valuable board space.

## Application Circuit

DC Summing Amplifier  
(VIN's 0 VDC and VO VDC)

## Feature

- $V_{CC} = 5V$ ,  $T_A = 25^\circ C$ .  
Typical values unless specified
- Gain-Bandwidth product 1MHz
- Low supply current  $430\mu A$
- Low input bias current 45nA
- Wide supply voltage range +3V to +32V
- Stable with high capacitive loads
- Single version of LM324

## Applications

- Chargers
- Power supplies
- Industrial: controls, instruments
- Desktops
- Communications infrastructure

## Ordering Information

Part Number	Package	Package Marking
LM321	SOT-23-5L	A63 A

## Connection Diagram

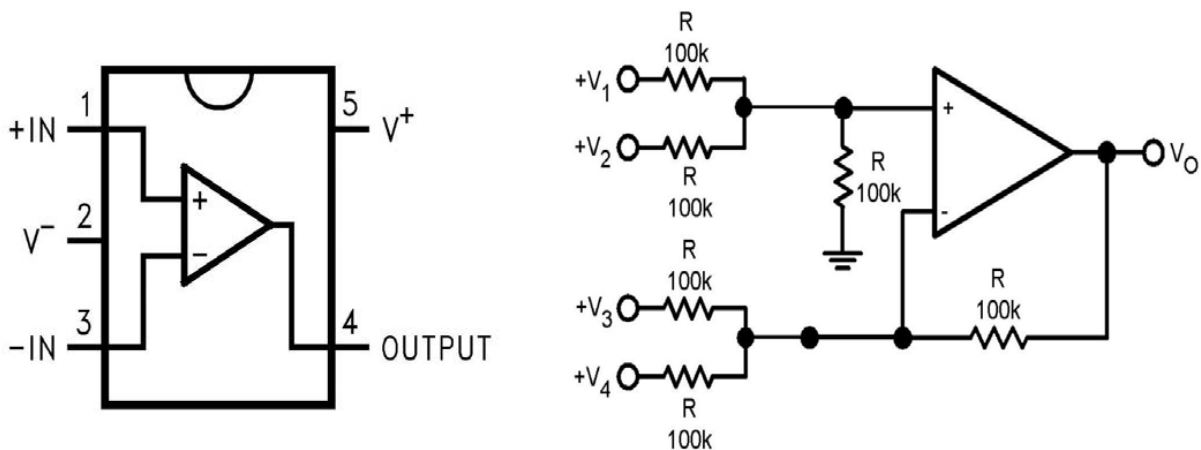

Where:  $V_0 = V_1 + V_2 - V_3 - V_4$ ,  $(V_1 + V_2) \geq (V_3 + V_4)$  to keep  $V_0 > 0$  VDC



### Absolute Maximum Ratings (Note 1)

If Military/Aerospace specified devices are required, please contact the National Semiconductor Sales Office/ Distributors for availability and specifications.

Parameter	Symbol	Ratings	Unit
Supply Voltage (V+ - V-)	VCC	32	V
Differential Input Voltage	VI (DIFF)	±Supply Voltage	V
Input Current (VIN < -0.3V) (Note 6)	IC	50	mA
Input Voltage		-0.3V to +32V	V
Output Short Circuit to GND, V+ ≤ 15V and TA = 25°C (Note 2)		Continuous	W
Thermal Resistance to Ambient	RθJA	265	°C/W
Junction Temperature (Note 3)	TJ	150	°C
Storage Temperature Range	TSTG	-65~+150	°C
ESD Tolerance (Note 10)		300	V
Mounting Temperature Lead Temp (Soldering, 10 sec)		260	°C
Infrared (10 sec)		215	°C

### Operating Ratings (Note 1)

Parameter	Symbol	Ratings	Unit
Temperature Range	TA	-40~85	°C
Supply Voltage	V+	3~30	V

### Pin Configuration

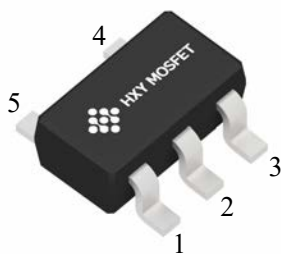

SOT-23-5L

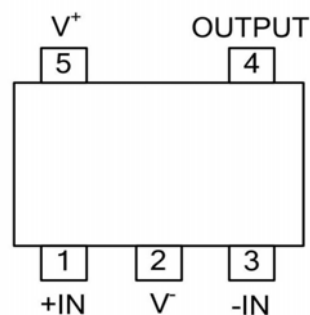

PIN NO.	PIN NAME	DESCRIPTION
1	+IN	Non-inverting input
2	V-	Ground
3	-IN	inverting input
4	OUTPUT	Output
5	V+	Power supply



**Electrical Characteristics (Ta = 25 °C Unless Otherwise specified)**

Unless otherwise specified, all limits guaranteed for at TA = 25°C; V+ = 5V, V- = 0V, VO = 1.4V.  
Boldface limits apply at temperature extremes.

Parameter	Symbol	Test Condition	Min (Note 5)	Typ (Note 4)	Max (Note 5)	Unit
Input Offset Voltage	VOS	(Note 7)		2	5	mV
Input Offset Current	IOS			3	30	nA
Input Bias Current (Note 8)	IB			45	150	nA
Input Common-Mode Voltage Range	VCM	V+ = 30V (Note 9) For CMRR > = 50dB	0		V+ - 1.5 V+ -2	V
Large Signal Voltage Gain	AV	V+ = 15V, RL = 2kΩ VO = 1V to 11V	50	100		V/mV
Power Supply Rejection Ratio	PSRR	RS ≤ 10kΩ, V+ ≤ 5V to 30V	75	100		dB
Common Mode Rejection Ratio	CMRR	RS ≤ 10kΩ,	70	90		dB
Output Swing	VOH	V+ = 30V, RL = 2kΩ	21	23		V
		V+ = 30V, RL = 10kΩ	22	24		V
	VOL	V+ = 50V, RL = 10kΩ		5	20	mV
Supply Current, No Load	IS	V+ = 5V,		0.1	0.3	mA
		V+ = 30V,		0.16	0.5	mA
Output Current Sourcing	I <sub>SOURCE</sub>	VID = +1V, V+ = 15V, VO = 2V	20	40		mA
Output Current Sinking	I <sub>SINK</sub>	VID = -1V V+ = 15V, VO = 2V		15		mA
		VID = -1V V+ = 15V, VO = 0.2V		50		μA
Output Short Circuit to Ground (Note 2)	IO	V+ = 15V		40	85	mA
Slew Rate	SR	V+ = 15V, RL = 2kΩ, VIN = 0.5 to 3V CL = 100pF, Unity Gain		0.4		V/μs
Gain Bandwidth Product	GBM	V+ = 30V, f = 100kHz, VIN = 10mV, RL = 2kΩ, CL = 100pF		1		MHz



**Electrical Characteristics (Ta = 25 °C Unless Otherwise specified)**

Unless otherwise specified, all limits guaranteed for at TA = 25°C; V+ = 5V, V- = 0V, VO = 1.4V.  
Boldface limits apply at temperature extremes.

Parameter	Symbol	Test Condition	Min (Note 5)	Typ (Note 4)	Max (Note 5)	Unit
Phase Margin	$\phi_m$			60		deg
Total Harmonic Distortion	THD	f = 1kHz, AV = 20dB RL = 2k $\Omega$ , VO = 2VPP, CL = 100pF, V+ = 30V		0.015		%
Equivalent Input Noise Voltage	en	f = 1kHz, RS = 100 $\Omega$ V+ = 30V		40		nV Hz

Note 1: Absolute Maximum Ratings indicate limits beyond which damage to the device may occur. Operating Ratings indicate conditions for which the device is intended to be functional, but specific performance is not guaranteed. For guaranteed specifications and the test conditions, see the Electrical Characteristics.

Note 2: Short circuits from the output V+ can cause excessive heating and eventual destruction. When considering short circuits to ground the maximum output current is approximately 40mA independent of the magnitude of V+. At values of supply voltage in excess of +15V, continuous short circuits can exceed the power dissipation ratings and cause eventual destruction.

Note 3: The maximum power dissipation is a function of TJ(MAX), qJA, and TA. The maximum allowable power dissipation at any ambient temperature is PD = (TJ(MAX) - TA) / qJA. All numbers apply for packages soldered directly onto a PC board.

Note 4: Typical values represent the most likely parametric norm.

Note 5: All limits are guaranteed by testing or statistical analysis.

Note 6: This input current will only exist when the voltage at any of the input leads is driven negative. It is due to the collector base junction of the input PNP transistors becoming forward biased and thereby acting as input diode clamps. In addition to this diode action, there is also lateral NPN parasitic transistor action on the IC chip. This transistor action can cause the output voltages of the op amps to go to the V+ voltage level (or to ground for a large overdrive) for the time duration that an input is driven negative. This is not destructive and normal output states will re-establish when the input voltage, which was negative, again returns to a value greater than -0.36V (at 25°C).

Note 7: VO @ 1.4V, RS = 0W with V+ from 5V to 30V; and over the full input common-mode range (0V to V+ - 1.5V) at 25°C.

Note 8: The direction of the input current is out of the IC due to the PNP input stage. This current is essentially constant, independent of the state of the output so no loading change exists on the input lines.

Note 9: The input common-mode voltage of either input signal voltage should not be allowed to go negative by more than 0.3V (at 25°C). The upper end of the common-mode voltage range is V+ - 1.5V at 25°C, but either or both inputs can go to +32V without damage, independent of the magnitude of V+.

Note 10: Human Body Model, 1.5kW in series with 100pF.

### Typical Performance Characteristics

Unless otherwise specified,  $V_S = +5V$ , single supply,  $T_A = 25^\circ C$ .

Small Signal Pulse Response

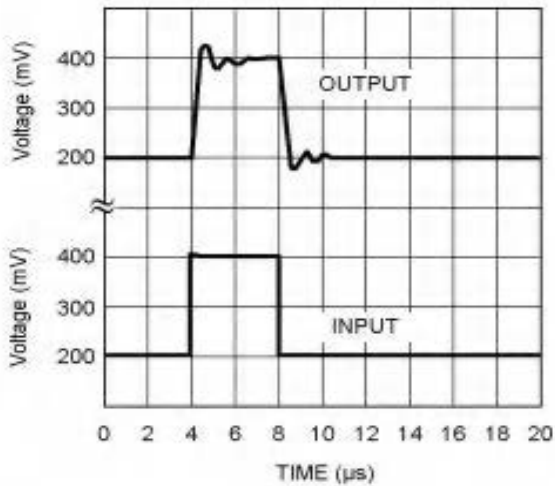

Large Signal Pulse Response

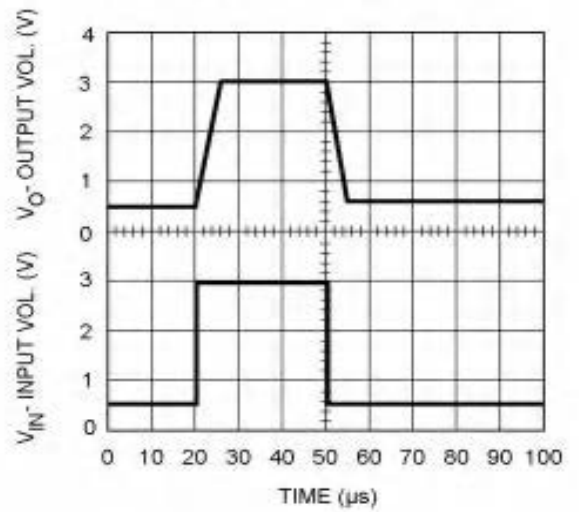

Supply Current vs. Supply Voltage

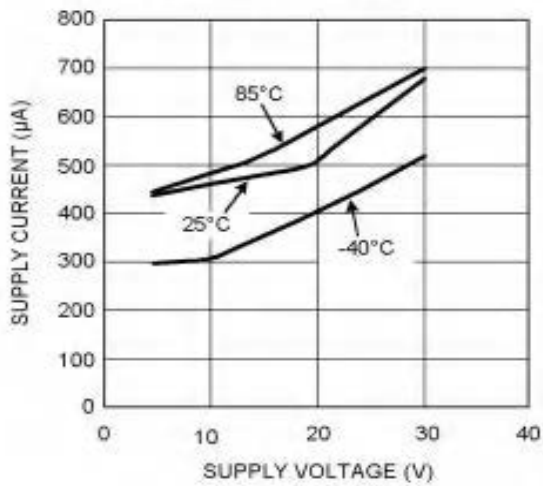

Sinking Current vs. Output Voltage

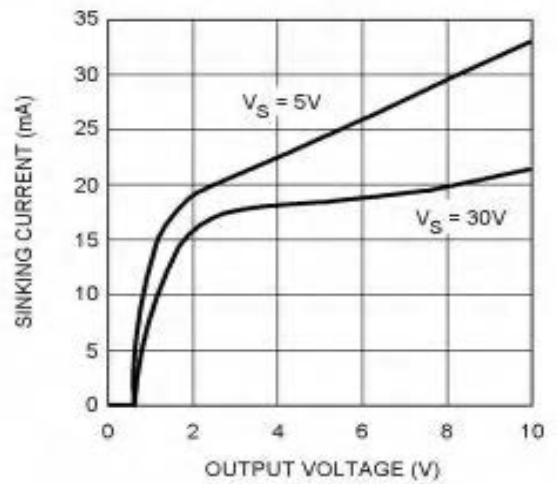

Source Current vs. Output Voltage

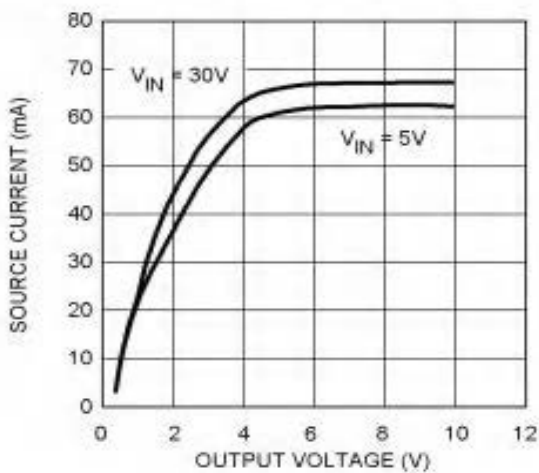

Open Loop Frequency Response

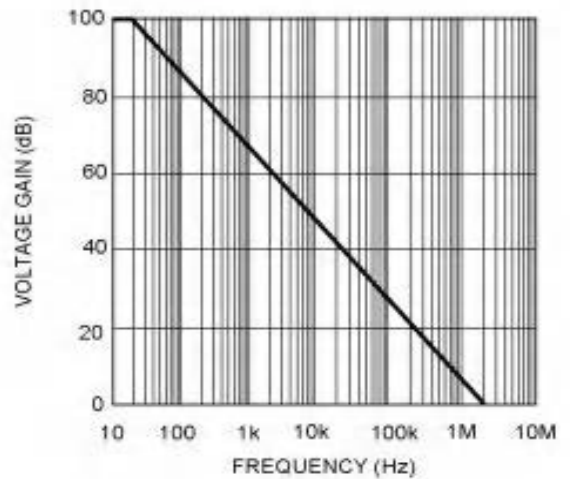

**Simplified Schematic**

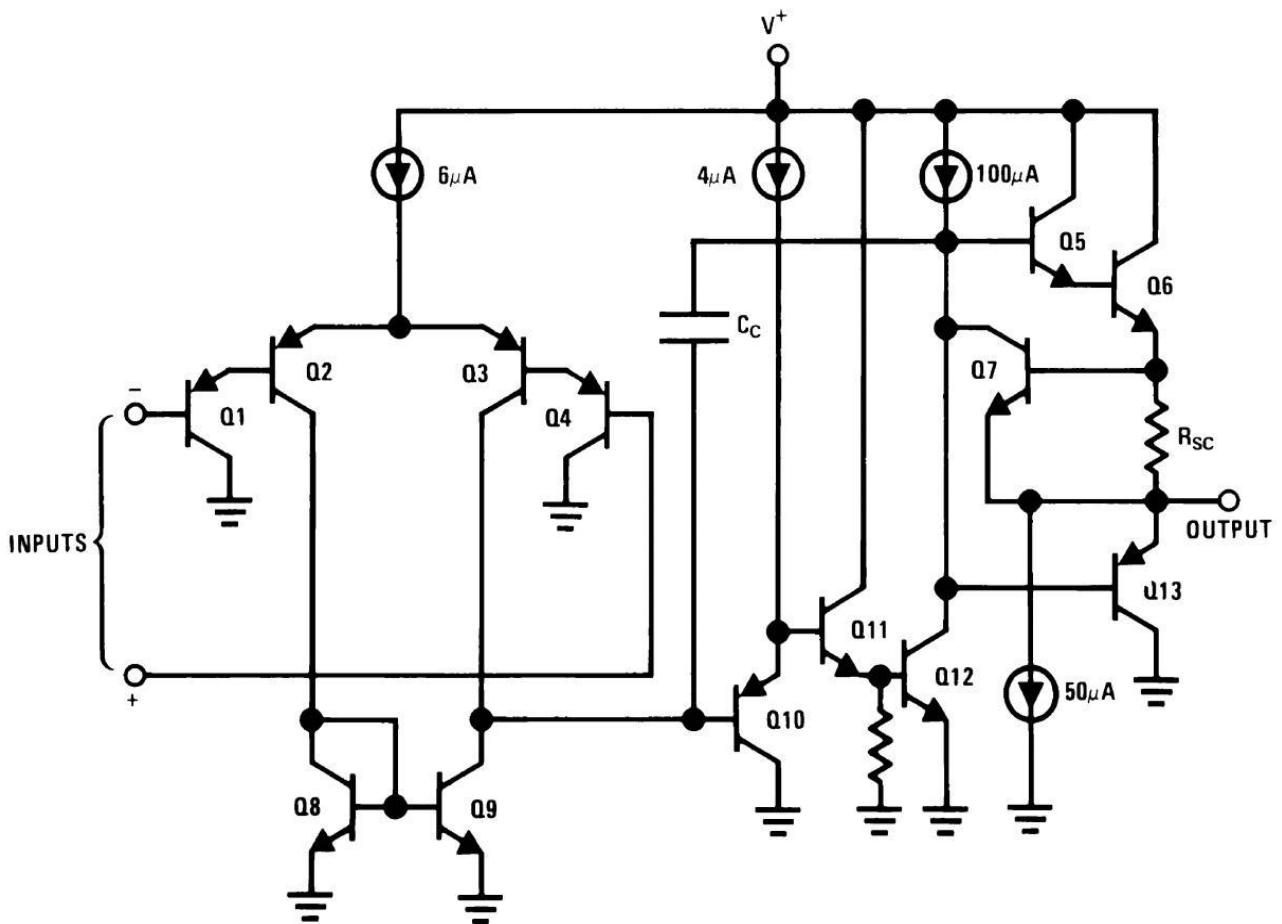

**Typical Applications**

Non-Inverting DC Gain (0V Input = 0V Output)

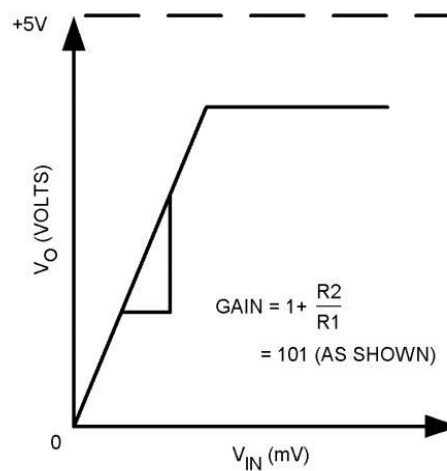
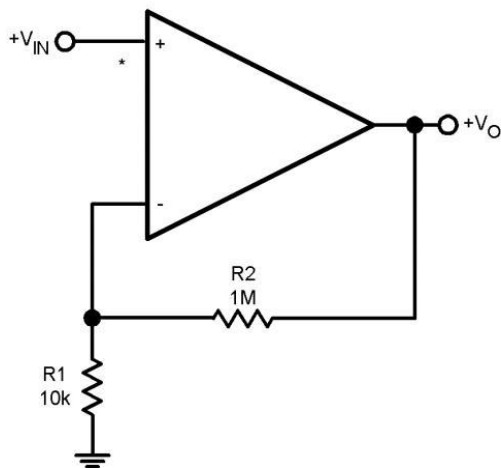

\* R NOT NEEDED DUE TO TEMPERATURE INDEPENDENT  $I_{IN}$



## Typical Applications

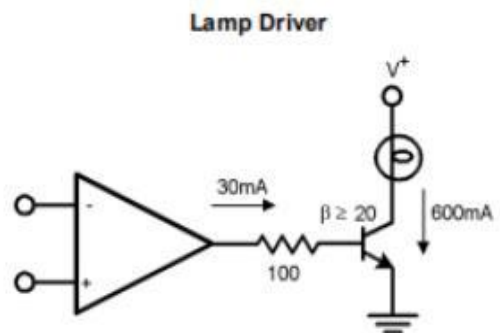
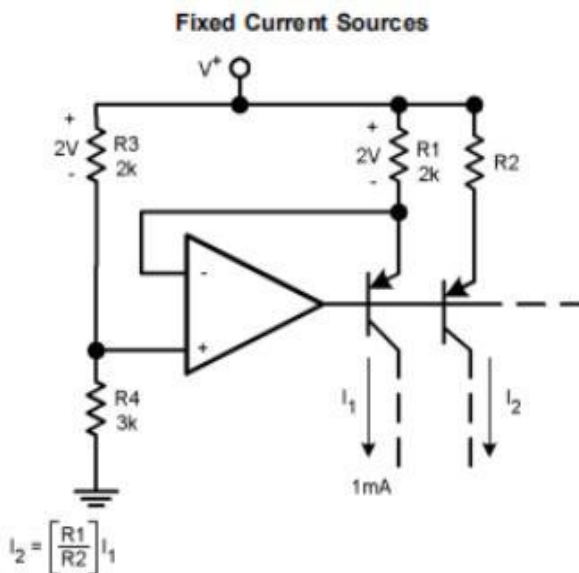
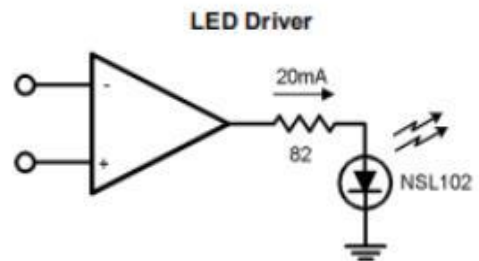
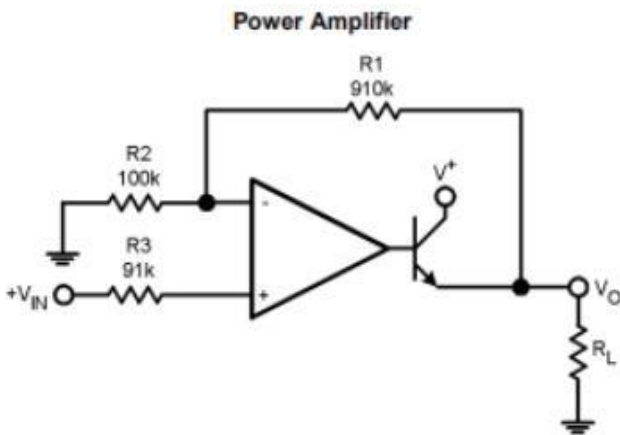
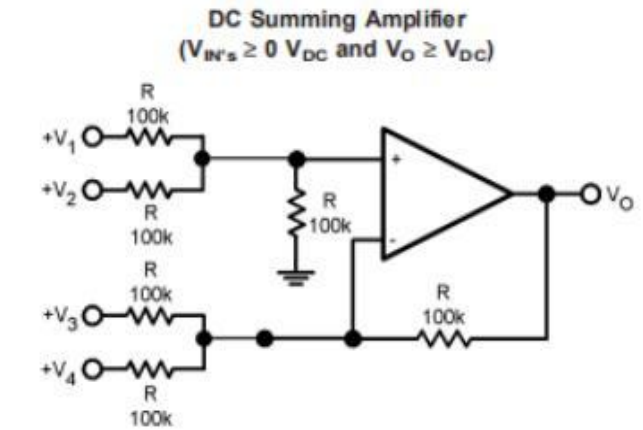
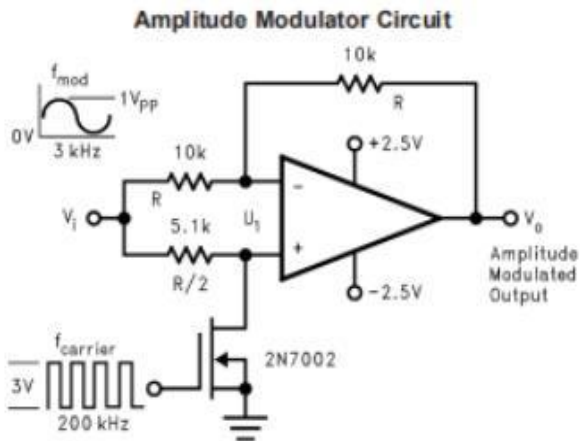



### SOT-23-5L Package Outline Dimensions

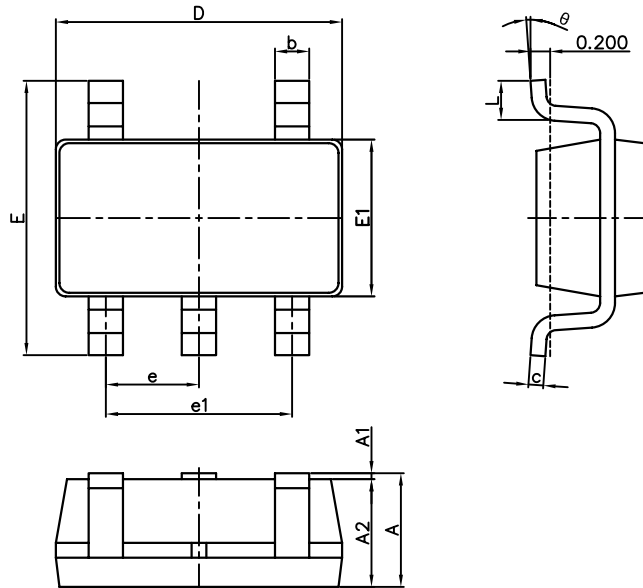

Symbol	Dimensions In Millimeters		Dimensions In Inches	
	Min.	Max.	Min.	Max.
A	1.050	1.250	0.041	0.049
A1	0.000	0.100	0.000	0.004
A2	1.050	1.150	0.041	0.045
b	0.300	0.500	0.012	0.020
c	0.100	0.200	0.004	0.008
D	2.820	3.020	0.111	0.119
E	2.650	2.950	0.104	0.116
E1	1.500	1.700	0.059	0.067
e	0.950(BSC)		0.037(BSC)	
e1	1.800	2.000	0.071	0.079
L	0.300	0.600	0.012	0.024
θ	0°	8°	0°	8°



### Attention

- Any and all HUA XUAN YANG ELECTRONICS products described or contained herein do not have specifications that can handle applications that require extremely high levels of reliability, such as life-support systems, aircraft's control systems, or other applications whose failure can be reasonably expected to result in serious physical and/or material damage. Consult with your HUA XUAN YANG ELECTRONICS representative nearest you before using any HUA XUAN YANG ELECTRONICS products described or contained herein in such applications.
- HUA XUAN YANG ELECTRONICS assumes no responsibility for equipment failures that result from using products at values that exceed, even momentarily, rated values (such as maximum ratings, operating condition ranges, or other parameters) listed in products specifications of any and all HUA XUAN YANG ELECTRONICS products described or contained herein.
- Specifications of any and all HUA XUAN YANG ELECTRONICS products described or contained herein stipulate the performance, characteristics, and functions of the described products in the independent state, and are not guarantees of the performance, characteristics, and functions of the described products as mounted in the customer's products or equipment. To verify symptoms and states that cannot be evaluated in an independent device, the customer should always evaluate and test devices mounted in the customer's products or equipment.
- HUA XUAN YANG ELECTRONICS CO.,LTD. strives to supply high-quality high-reliability products. However, any and all semiconductor products fail with some probability. It is possible that these probabilistic failures could give rise to accidents or events that could endanger human lives, that could give rise to smoke or fire, or that could cause damage to other property. When designing equipment, adopt safety measures so that these kinds of accidents or events cannot occur. Such measures include but are not limited to protective circuits and error prevention circuits for safe design, redundant design, and structural design.
- In the event that any or all HUA XUAN YANG ELECTRONICS products(including technical data, services) described or contained herein are controlled under any of applicable local export control laws and regulations, such products must not be exported without obtaining the export license from the authorities concerned in accordance with the above law.
- No part of this publication may be reproduced or transmitted in any form or by any means, electronic or mechanical, including photocopying and recording, or any information storage or retrieval system, or otherwise, without the prior written permission of HUA XUAN YANG ELECTRONICS CO.,LTD.
- Information (including circuit diagrams and circuit parameters) herein is for example only ; it is not guaranteed for volume production. HUA XUAN YANG ELECTRONICS believes information herein is accurate and reliable, but no guarantees are made or implied regarding its use or any infringements of intellectual property rights or other rights of third parties.
- Any and all information described or contained herein are subject to change without notice due to product/technology improvement, etc. When designing equipment, refer to the "Delivery Specification" for the HUA XUAN YANG ELECTRONICS product that you intend to use.