



## General Description

The LM2576S-3.3/NOPB is a series of easy to use fixed and adjustable step-down (buck) switch-mode voltage regulators. These devices are available in fixed output voltage of 3.3V, 5V, and an adjustable output version. Both versions are capable of driving a 3.5A load with excellent line and load regulation.

Requiring a minimum number of external components, these regulators are simple to use and include internal frequency compensation, and a fixed-frequency oscillator.

The output voltage is guaranteed to  $\pm 3\%$  tolerance under specified input voltage and output load conditions. The oscillator frequency is guaranteed to  $\pm 15\%$ . External shutdown is included, featuring typically 80  $\mu\text{A}$  standby current. Self protection features include a two stage frequency reducing current limit for the output switch and an over temperature shutdown for complete protection under fault conditions.

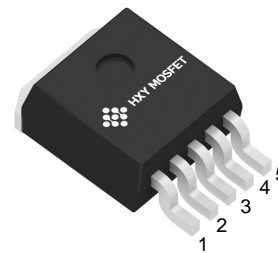

5 ON/OFF  
4 Feedback  
3 Gnd  
2 Output  
1 Vin

**TO-263-5L**  
**(TO-263-5)**

## Features

- 3.3V, 5V and adjustable output versions
- Output adjustable from 1.23v to 37V
- Fixed 52KHz frequency internal oscillator
- Guaranteed 3.5A output load current
- Input voltage range up to 40V
- Low power standby mode,  $I_Q$  typically 80  $\mu\text{A}$
- TTL shutdown capability
- Excellent line and load regulation
- Requires only 4 external components
- High efficiency
- Thermal shutdown and current limit protection

Name	Description
Vin	Input supply voltage
Output	Switching output
Gnd	Ground
Feedback	Output voltage feedback
ON/OFF	ON/OFF shutdown Active is "Low" or floating

## Pin Descriptions

## Applications

- Simple High-efficiency step-down regulator
- On-card switching regulators
- Positive to negative converter
- LCD monitor and LCD TV
- DVD recorder and PDP TV
- Battery charger
- Step-down to 3.3V for microprocessors



### Functional Block Diagram

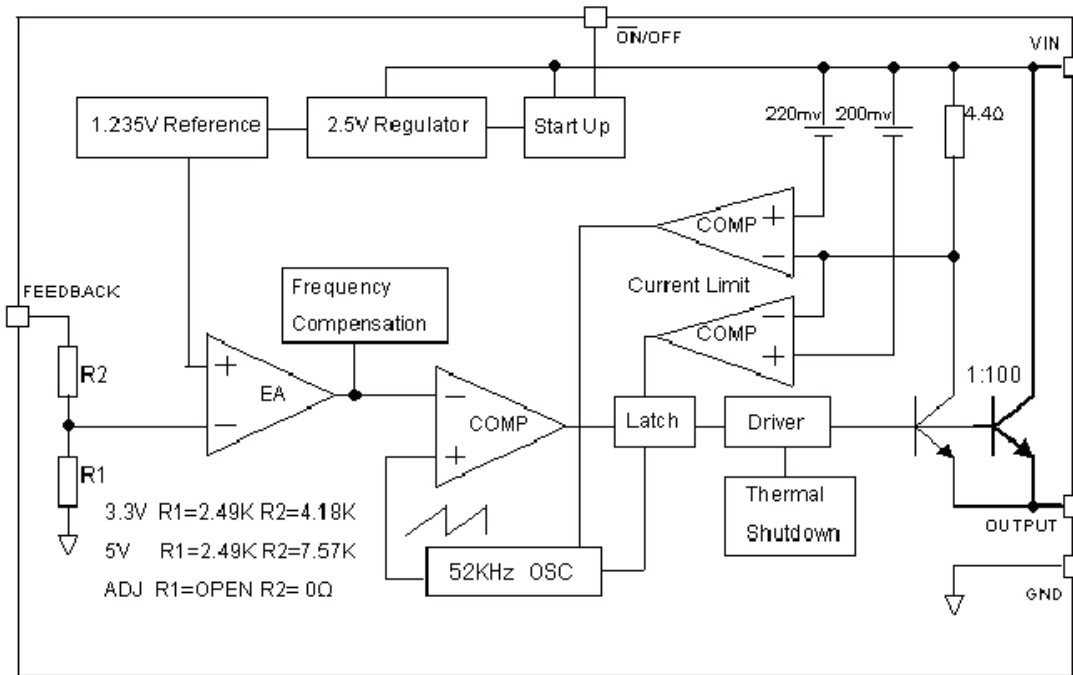

Functional Block Diagram of LM2576S-xx/NOPB

### Typical Application (Fixed Output Voltage Versions)

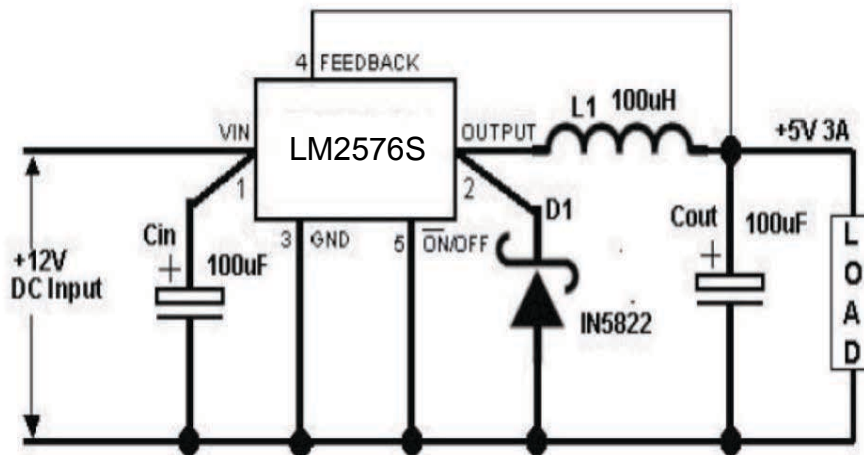

Typical Application of LM2576Sxx/NOPB



## Absolute Maximum Ratings

Note1: Stresses greater than those listed under Maximum Ratings may cause permanent damage to the device. This is a stress rating only and functional operation of the device at these or any other conditions above those indicated in the operation is not implied. Exposure to absolute maximum rating conditions for extended periods may affect reliability.

Parameter	Value	Unit
Supply Voltage $V_{in}$	-0.3 to 40	V
Feedback VFB pin voltage	-0.3 to $V_{in}+0.3$	V
ON/OFF Pin voltage	-0.3 to $V_{in}+0.3$	V
Output pin voltage	-0.3 to $V_{in}+0.3$	V
Output Voltage to Ground (Steady State)	-1	V
Power Dissipation	Internally limited	W
Operating Temperature Range	-40 to +125	°C
Storage Temperature	-65 to +150	°C
Lead Temperature (Soldering, 10 sec)	260	°C
ESD(HM)	2000	V
Thermal Resistance-Junction to Ambient( $R_{\theta JA}$ )	85	°C / W
Thermal Resistance-Junction to Case( $R_{\theta JC}$ )	45	°C / W

## Electrical Characteristics (All Output Voltage Versions)

Unless otherwise specified,  $T_a = 25^{\circ}\text{C}$ .

Symbol	Parameter	Conditions	Min.	Typ.	Max.	Unit
$I_b$	Feedback bias current	Adjustable only, $V_{FB}=1.3\text{V}$		10	50	nA
$I_Q$	Quiescent current	$V_{FB}=12\text{V}$ force driver off		5	10	mA
$I_{STBY}$	Standby quiescent current	ON/OFF=5V, $V_{IN}=36\text{V}$		80	200	uA
$F_{OSC}$	Oscillator frequency		47	52	58	KHz
$V_{SAT}$	Saturation voltage	$I_{OUT}=3.5\text{A}$		1.2	1.4	V
$I_{CL}$	Current Limit	Peak Current ( $V_{FB}=0\text{V}$ )		4.5	5.5	A
$I_L$	Output leakage current	Output=0V ( $V_{FB}=12\text{V}$ )			50	uA
	Output leakage current	Output=-1V ( $V_{IN}=36\text{V}$ )		2	30	mA
$V_{IL}$	ON/OFF pin logic input	Low (Regulator ON)		1.3	1.6	V



$V_{IH}$	Threshold voltage	High (Regulator OFF)	2.0	1.3		V
$I_H$ $I_L$	ON/OFF pin input current	$V_{LOGIC}=2.5V$ (Regulator OFF)		5	15	$\mu A$
		$V_{LOGIC}=0.5V$ (Regulator ON)		0.02	5	$\mu A$
$\theta_{JC}$	Thermal Resistance Junction to Case			3.5		$^{\circ}C/W$
$\theta_{JA}$	Thermal Resistance Junction to Ambient (Note1)			23		$^{\circ}C/W$
LM2576 S-ADJ	Vout: Output Voltage	$11V \leq V_{IN} \leq 40V, 0.2A \leq I_{LOAD} \leq 3.5A, V_{OUT}$ for 9V	1.193	1.23	1.267	V
	$\eta$ : Efficiency	$V_{IN}=12V, V_{OUT}=9V, I_{LOAD}=3.5A$		88		%
LM2576 S-3.3V	Vout: Output Voltage	$4.75V \leq V_{IN} \leq 40V, 0.2A \leq I_{LOAD} \leq 3.5A$	3.168	3.3	3.432	V
	$\eta$ : Efficiency	$V_{IN}=12V, I_{LOAD}=3.5A$		76		%
LM2576 S-5V	Vout: Output Voltage	$7V \leq V_{IN} \leq 40V, 0.2A \leq I_{LOAD} \leq 3.5A$	4.800	5.0	5.200	V
	$\eta$ : Efficiency	$V_{IN}=12V, I_{LOAD}=3.5A$		83		%

Specifications with **boldface type** are for full operating temperature range, the other type are for  $T_J=25^{\circ}C$ .

Note1: Thermal resistance with copper area of approximately 3 in<sup>2</sup>.

## Typical Performance Characteristics

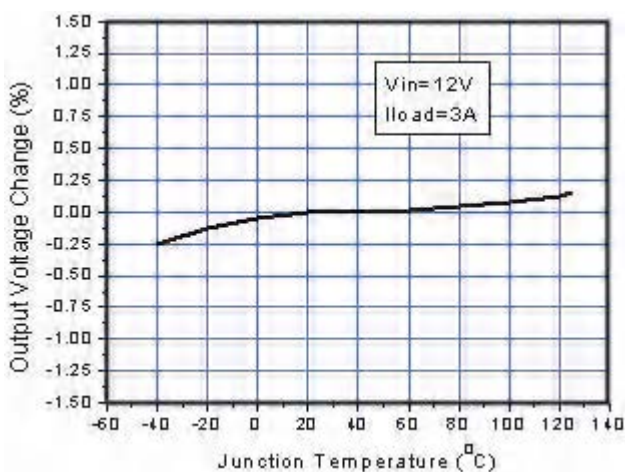

Figure 1. Output Voltage vs. Temperature

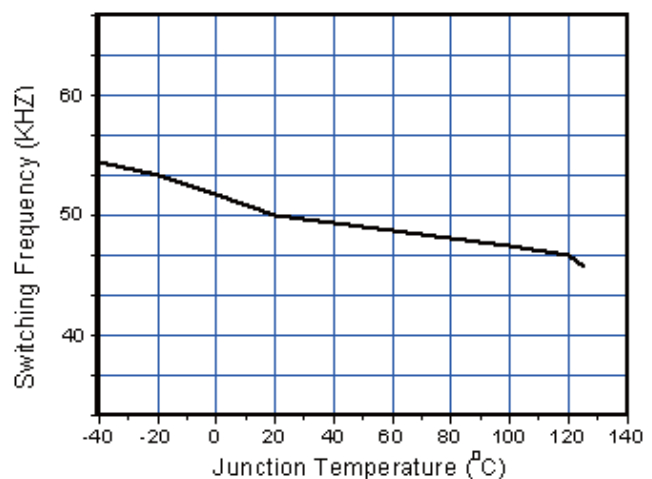

Figure 2. Switching Frequency vs. Temperature

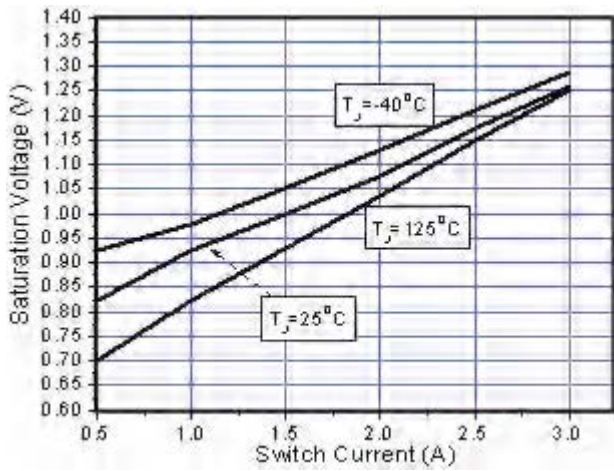

Figure 3. Output Saturation Characteristics

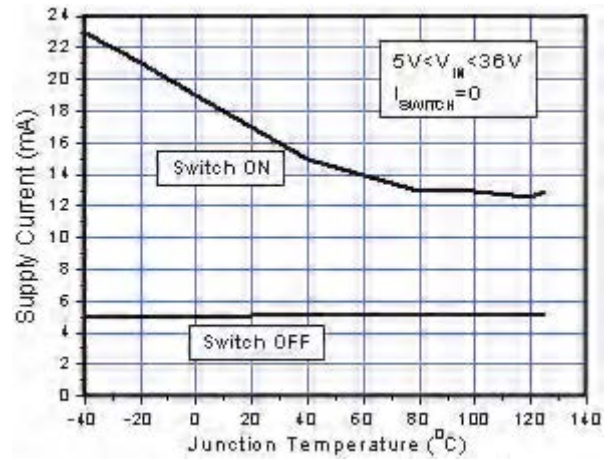

Figure 4. Quiescent Current vs. Temperature

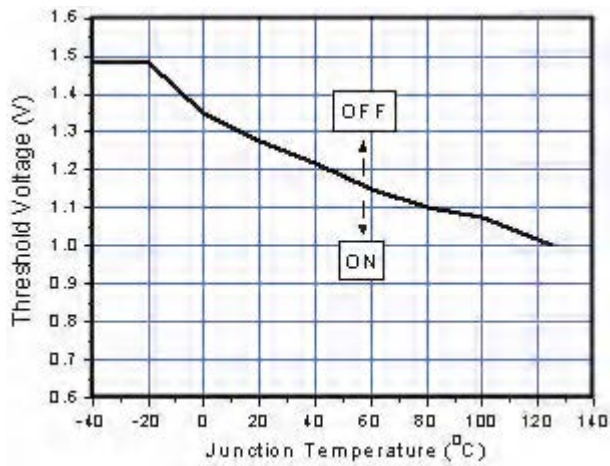

Figure 5. ON/OFF Pin Voltage

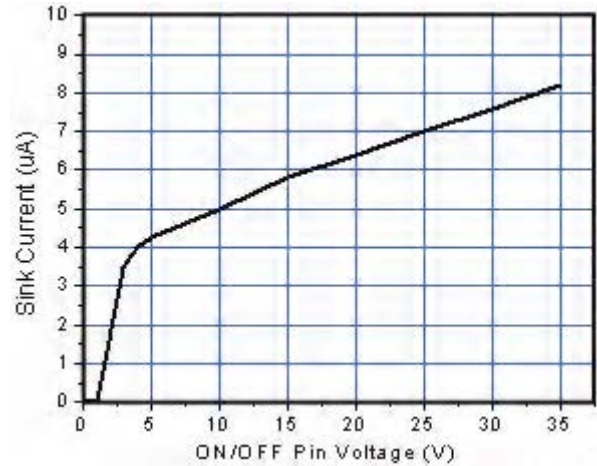

Figure 6. ON/OFF Pin Sink Current

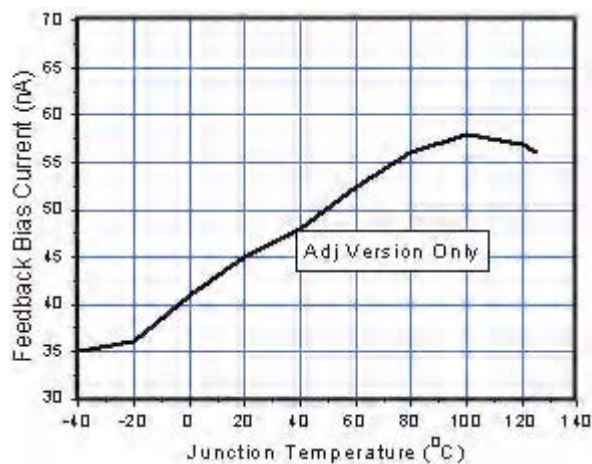

Figure 7. Output Saturation Characteristics



## Typical Application Circuit

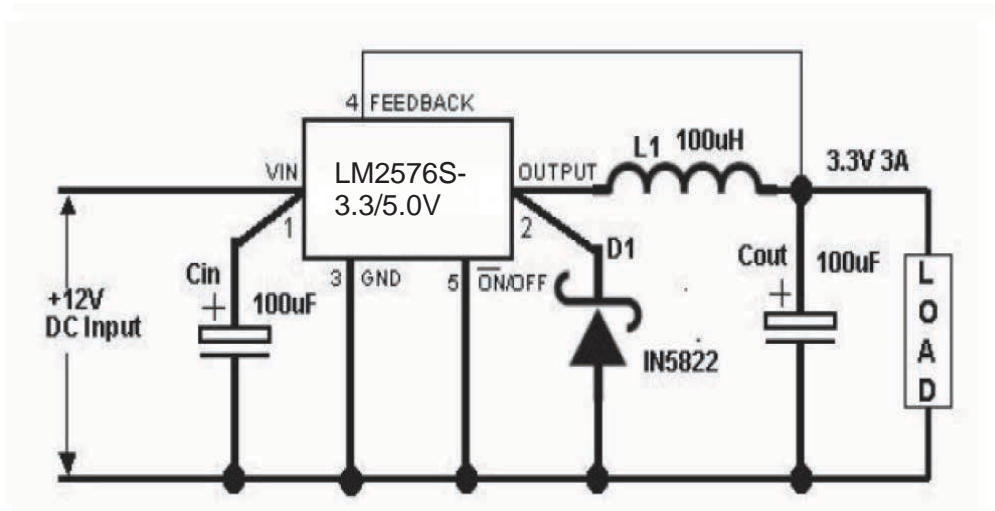

Figure 8. Typical Application of LM2576S For 3.3V,5.0V

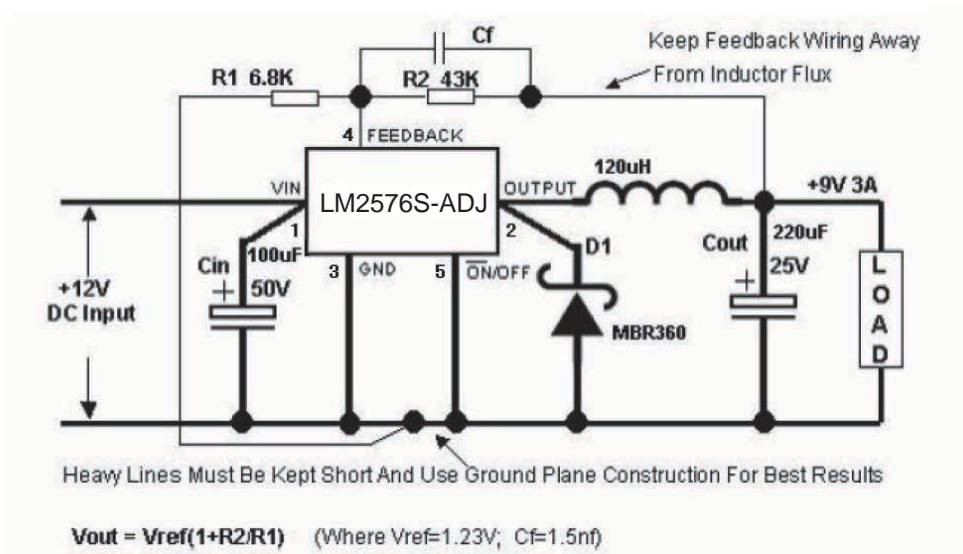
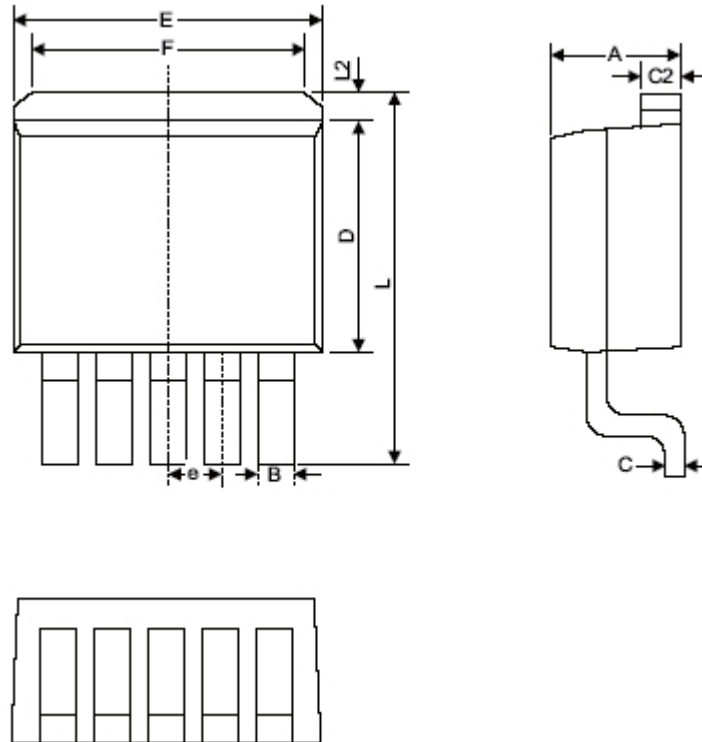

Figure 9. Typical Application of LM2576S For ADJ



## Package Information

### TO-263-5L (TO-263-5)



Symbol	Dimensions In Millimeters		Dimensions In Inches	
	Min.	Max.	Min.	Max.
A	4.06	4.83	0.160	0.190
B	0.76	1.02	0.030	0.040
C	0.36	0.64	0.014	0.025
C2	1.14	1.40	0.045	0.055
D	8.64	9.65	0.340	0.380
E	9.78	10.54	0.385	0.415
e	1.57	1.85	0.062	0.073
F	6.60	7.11	0.260	0.280
L	15.11	15.37	0.595	0.605
L2	-	1.40	-	0.055



### Attention

- Any and all HUA XUAN YANG ELECTRONICS products described or contained herein do not have specifications that can handle applications that require extremely high levels of reliability, such as life-support systems, aircraft's control systems, or other applications whose failure can be reasonably expected to result in serious physical and/or material damage. Consult with your HUA XUAN YANG ELECTRONICS representative nearest you before using any HUA XUAN YANG ELECTRONICS products described or contained herein in such applications.
- HUA XUAN YANG ELECTRONICS assumes no responsibility for equipment failures that result from using products at values that exceed, even momentarily, rated values (such as maximum ratings, operating condition ranges, or other parameters) listed in products specifications of any and all HUA XUAN YANG ELECTRONICS products described or contained herein.
- Specifications of any and all HUA XUAN YANG ELECTRONICS products described or contained herein stipulate the performance, characteristics, and functions of the described products in the independent state, and are not guarantees of the performance, characteristics, and functions of the described products as mounted in the customer's products or equipment. To verify symptoms and states that cannot be evaluated in an independent device, the customer should always evaluate and test devices mounted in the customer's products or equipment.
- HUA XUAN YANG ELECTRONICS CO.,LTD. strives to supply high-quality high-reliability products. However, any and all semiconductor products fail with some probability. It is possible that these probabilistic failures could give rise to accidents or events that could endanger human lives, that could give rise to smoke or fire, or that could cause damage to other property. When designing equipment, adopt safety measures so that these kinds of accidents or events cannot occur. Such measures include but are not limited to protective circuits and error prevention circuits for safe design, redundant design, and structural design.
- In the event that any or all HUA XUAN YANG ELECTRONICS products(including technical data, services) described or contained herein are controlled under any of applicable local export control laws and regulations, such products must not be exported without obtaining the export license from the authorities concerned in accordance with the above law.
- No part of this publication may be reproduced or transmitted in any form or by any means, electronic or mechanical, including photocopying and recording, or any information storage or retrieval system, or otherwise, without the prior written permission of HUA XUAN YANG ELECTRONICS CO.,LTD.
- Information (including circuit diagrams and circuit parameters) herein is for example only ; it is not guaranteed for volume production. HUA XUAN YANG ELECTRONICS believes information herein is accurate and reliable, but no guarantees are made or implied regarding its use or any infringements of intellectual property rights or other rights of third parties.
- Any and all information described or contained herein are subject to change without notice due to product/technology improvement, etc. When designing equipment, refer to the "Delivery Specification" for the HUA XUAN YANG ELECTRONICS product that you intend to use.