

M29504/04
181-002

Size 16 MIL-DTL-38999 Series III Type Fiber Optic Pin Terminus



MIL-DTL-38999



Ultra low dB loss QPL'd pin terminus for MIL-DTL-38999 Series III



Part Number	Fiber Size Core/Cladding/Coating	Ø A (Microns)	Ref. M29504/04-XXXX
181-002-125	9/125 (Singlemode)	125.5	M29504/04-4208
181-002-126S	9/125 (Singlemode)	126.0	M29504/04-4209
181-002-126	50/125 & 62.5/125	126.0	M29504/04-4210
181-002-127	50/125 & 62.5/125	127.0	M29504/04-4040
181-002-142	100/140	142.0	M29504/04-4043
181-002-144	100/140	144.0	N/A
181-002-145	100/140	145.0	M29504/04-4044
181-002-156	62.5/125/155 (Polyimide)	156.0	M29504/04-4211
181-002-157	62.5/125/155 (Polyimide)	157.0	M29504/04-4212
181-002-173	100/140/172 (Polyimide)	173.0	M29504/04-4087
181-002-175	100/140/172 (Polyimide)	175.0	M29504/04-4213
181-002-231	200/230	231.0	N/A
181-002-236	200/230	236.0	M29504/04-4214
181-002-286	200/280	286.0	M29504/04-4215
181-002-448	400/440	448.0	M29504/04-4216
181-002-533	486/500	533.0	N/A

Consult factory for additional sizes and QPL status.

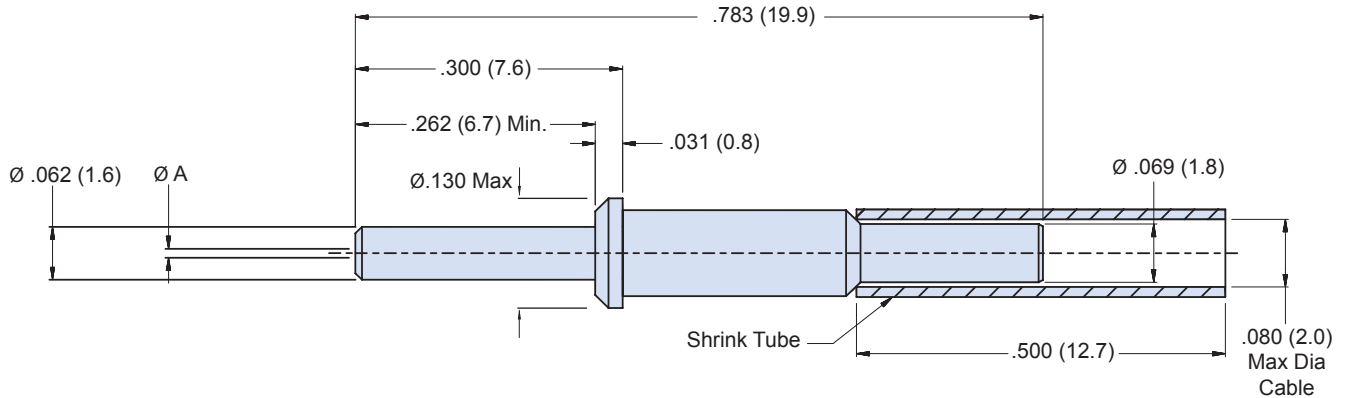

Material and Finish

Ferrule: Zirconia Ceramic
Terminus Assembly: Stainless Steel/Passivate
Shrink Tube: Kynar

Notes

See Glenair assembly procedure GAP-015 for complete termination instructions.
Recommended Insertion/Extraction tool: P/N M81969/14-03 or equivalent