



Descriptions

The BL1532TQFN is a bidirectional low-power dual port, high-speed, USB 2.0 analog switch with integrated protection for USB Type-C™ systems. The device is configured as a dual 2:1 or 1:2 switch. It is optimized for use with the USB 2.0 DP/DM lines in a USB Type-C™ system. The device is capable of true isolation. Even when COM+/- overrides VCC, very little current will flow back to the supply.

The BL1532TQFN has low bit-to-bit skew and high channel-to-channel noise isolation, and is compatible with various standards, such as high-speed USB 2.0 (480Mbps). Each switch is bidirectional and offers little or no attenuation of the high-speed signals at the outputs. Its bandwidth is wide enough to pass high-speed USB 2.0 differential signals (480 Mb/s) with good signal integrity.

GPIO control of SEL 1.8V logic compatible. The BL1532TQFN is available in QFN1418(QFN-10(1.8x1.4)) with Pb-free and Halogen-free making it a perfect candidate for mobile and space constrained applications.

Order Information

Package		Part Number	Top-Side Marking
QFN1418(QFN-10(1.8x1.4))	Tape and Reel	BL1532TQFN	A26 /GYW

Features

- Pin-to-Pin FSUSB42, NX3DV42, WAS7227, SGM7227, RS2228, BL1532
- Low On-resistance, Ron=1.5Ω when VCC =5V
- 1.8V Logic Compatible Control Pin
- COM+/- Overrides VCC to Achieve True Isolation Even When Supply Is Dead
- High Off-Isolation: -100dB @ 100KHz
- Low Channel-to-Channel Crosstalk: -97dB @ 100KHz
- High Bandwidth (-3dB @800MHz) Suitable for USB2.0 High-Speed Routing
- Low Quiescent Current (<2uA) With Very Wide Supply Range (1.5V ~ 5.5V)

Applications

- Anywhere a USB Type-C™ or Micro-B Connector is Used
- Mobile Phones, Tablets and Notebooks



Pin Configuration

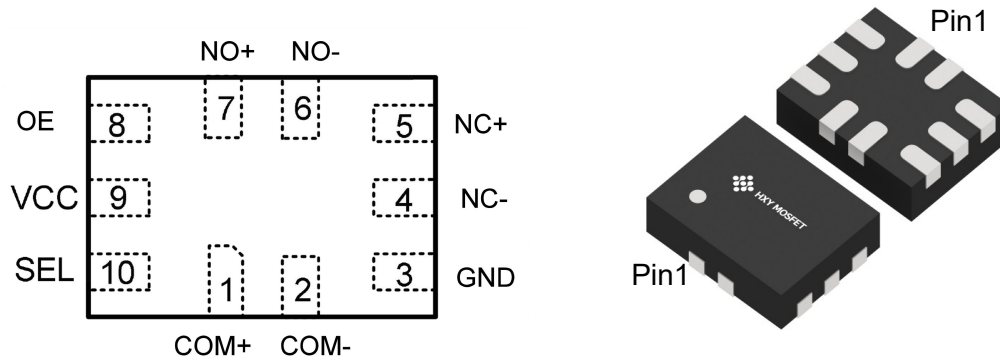

QFN1418(QFN-10(1.8x1.4))

Functions and Pin Configuration

Pin Number	Symbol	Descriptions
1,2	COM _x	Common Signal Ports
3	OE	Active Low
8	GND	Ground
4,5	NC _x	Analog/Digital Signal Ports (Normally closed)
6,7	NO _x	Analog/Digital Signal Ports (Normally open)
9	VCC	Single Power Supply
10	SEL	Logic Input Selection

Function Descriptions

Input SEL	Function
0	NC1=COM1 and NC2=COM2
1	NO1=COM1 and NO2=COM2

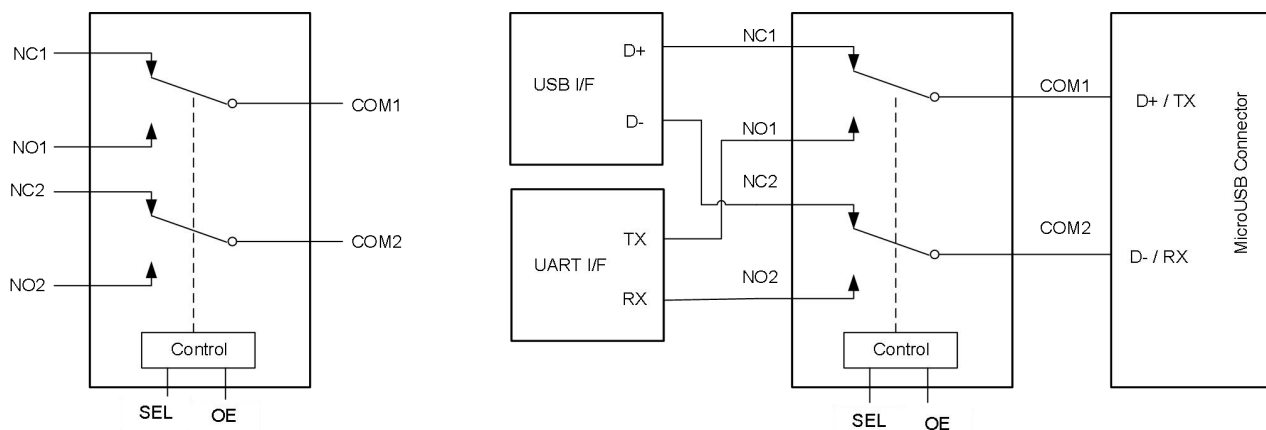



Absolute Maximum Ratings ⁽¹⁾

Parameter	Symbol	Value	Unit
Supply Voltage	V _{CC}	-0.3 ~ 6.5	V
Control Input Voltage	V _{IN}	-0.3 ~ 6.5	V
Continuous Current Through NO, NC, COM		±100	mA
Peak Current Through NO, NC, COM (pulsed at 1ms 50% duty cycle)		±200	mA
Storage Temperature Range	T _{STG}	-55 ~ 150	°C
Junction Temperature under Bias	T _J	150	°C
Lead Temperature (Soldering, 10 seconds)	T _L	260	°C
Power Dissipation	P _D	250	mW

Recommend operating ratings ⁽²⁾

Parameter	Symbol	Value	Unit
Supply Voltage Operating	V _{CC}	1.5 ~ 5.5	V
Control Input Voltage	V _{IN}	-0.3 ~ 5.5	V
Input Signal Voltage	V _{COM}	-0.3 ~ 5.5	V
Operating Temperature	T _A	-40 ~ 85	°C
Thermal Resistance	R _{θJA}	360	°C/W

Note:

1. "Absolute Maximum Ratings" may cause permanent damage to the device. This is a stress only rating and operation of the device at these or any other conditions beyond those indicated in the operational sections of this specification is not implied.

Capacitance (T_a=25°C, V_{CC}=3.3V, unless otherwise noted)

Parameter	Symbol	Conditions	Min.	Typ.	Max.	Unit
Off capacitance	C _{OFF}	F=100KHz		5		pF
On capacitance	C _{ON}	F=100KHz		7		pF



DC Electronics Characteristics (Ta=25°C, VCC=3.3V, unless otherwise noted)

Parameter	Symbol	Conditions	Min.	Typ.	Max	Unit
Input logic high level	V _{IH}	V _{CC} : 3.3 ~ 5.5V	1.6			V
		V _{CC} : 1.5 ~ 3.3V	1.4			V
Input logic low level	V _{IL}	V _{CC} : 3.3 ~ 5.5V			0.6	V
		V _{CC} : 1.5 ~ 3.3V			0.4	V
Supply quiescent current	I _{CC}	I _{COM} =0, V _{IN} =0 or V _{IN} =V _{CC}			1.0	uA
Increase in I _{CC} per input	I _{CC} T	I _{COM} =0, V _{CC} =4.5V V _{IN} >1.8 or V _{IN} <0.5			1.0	uA
Off state leakage from COM _x to NC _x (or NO _x)	I _{COMx}	V _{COM} = 5.5V , V _{NC(or NO)} = 0V			±2.0	uA
On-Resistance	R _{ON1}	V _{COM} =0 ~ 0.5V, I _{COM} =30mA		3.0	3.5	Ω
	R _{ON2}	V _{COM} =0.5 ~ 2.0V, I _{COM} =30mA		3.6	3.9	Ω
	R _{ON3}	V _{COM} =2.0 ~ 4.0V, I _{COM} =30mA		2.5	3.5	Ω
	R _{ON4}	V _{COM} =4.0 ~ 5.5V, I _{COM} =30mA		1.5	1.8	Ω
On-Resistance Flatness	R _{FLAT1}	V _{COM} =0 ~ 0.5V, I _{COM} =30mA		0.7		Ω
	R _{FLAT2}	V _{COM} =0.5 ~ 2.0V, I _{COM} =30mA		0.5		Ω
	R _{FLAT3}	V _{COM} =2.0 ~ 4.0V, I _{COM} =30mA		1.6		Ω
	R _{FLAT4}	V _{COM} =4.0 ~ 5.5V, I _{COM} =30mA		0.3		Ω
On-Resistance Matching Between Channels	Δ R _{ON}	V _{COM} =0~5.5V, I _{COM} =30mA,		0.1	0.2	Ω

AC Electronics Characteristics (Ta=25°C, VCC=3.3V, unless otherwise noted)

Parameter	Symbol	Conditions	Min.	Typ.	Max	Unit
Turn-On Time	T _{ON}	V _{COM} =1.5V, C _L =35pF, R _L =50Ω		200		ns
Turn-Off Time	T _{OFF}	V _{COM} =1.5V, C _L =35pF, R _L =50Ω		200		ns
Break-Before-Make time	T _B BM	V _{COM} =1.5V, C _L =35pF, R _L =50Ω		500		ns
-3dB Bandwidth	BW	R _L =50Ω, C _L =0pF		800		MHz
Off isolation	OIRR	F=1KHz, R _L =50Ω		-81		dB
		F=10KHz, R _L =50Ω		-80		dB
Crosstalk	Xtalk	F=1KHz, R _L =50Ω		-83		dB
		F=10KHz, R _L =50Ω		-82		dB
Total Harmonic Distortion	THD	F=20Hz to 20KHz V _{COM} =600mVp-p @R _L =32Ω,		-80		dB



Typical Characteristics (Ta=25°C, VCC=3.3V, unless otherwise noted)

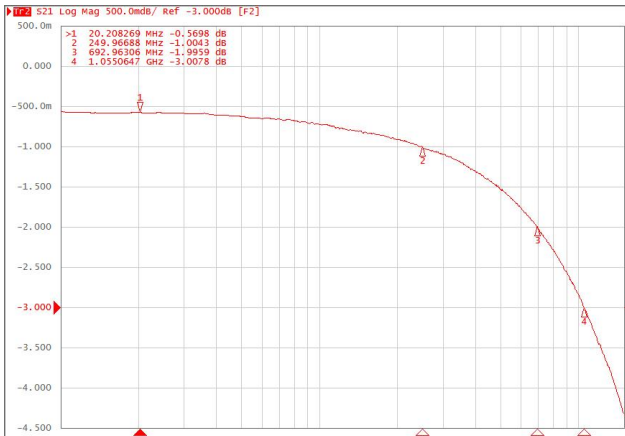

Bandwidth

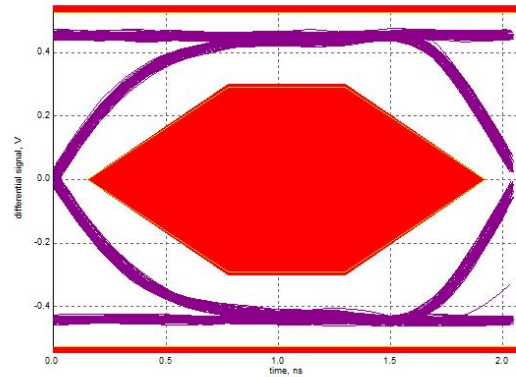

Eye Diagram (480Mbps)

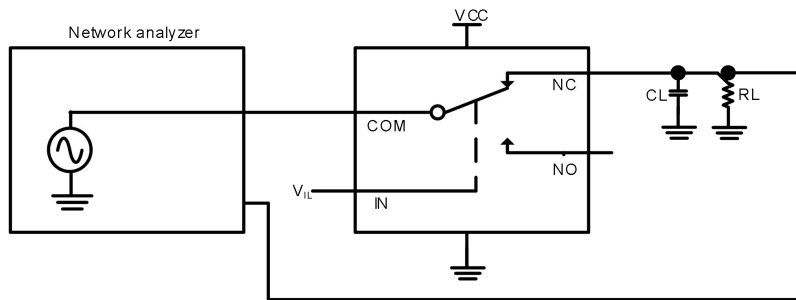

Bandwidth

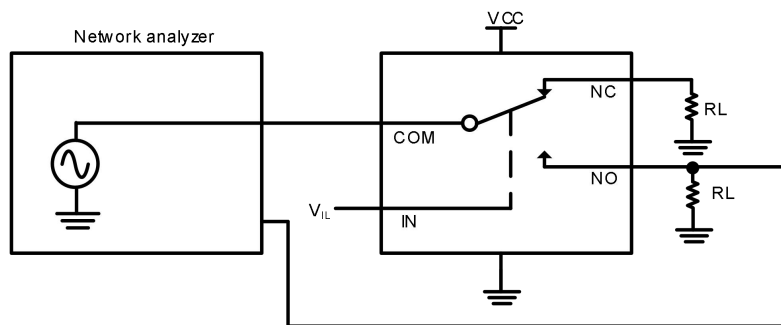

Off isolation

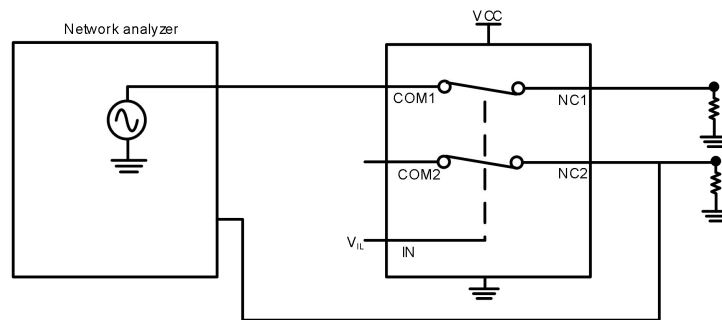

Crosstalk



Package Outline Dimensions

QFN1418(QFN-10(1.8x1.4))

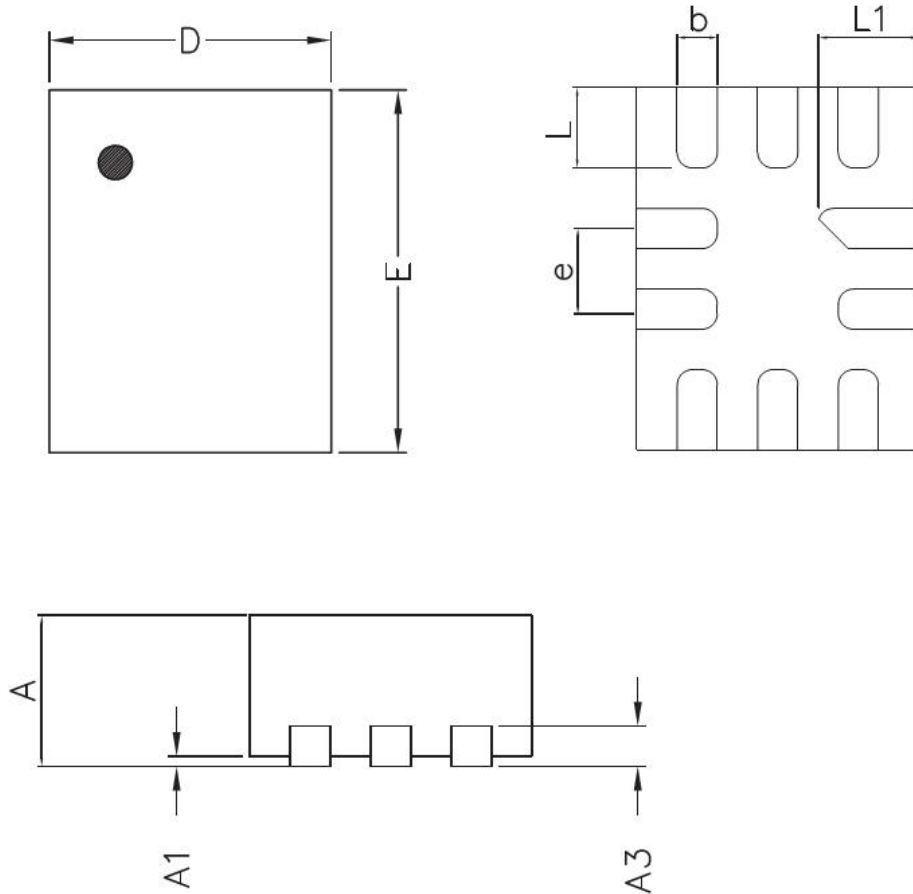

Symbol	Dimension in Millimeters	
	Min.	Max.
A	0.450	0.550
A1	0.000	0.050
A3	0.152 Ref.	
D	1.350	1.450
E	1.750	1.850
b	0.150	0.250
e	0.400 Typ.	
L	0.350	0.450
L1	0.450	0.550



Attention

- Any and all HUA XUAN YANG ELECTRONICS products described or contained herein do not have specifications that can handle applications that require extremely high levels of reliability, such as life-support systems, aircraft's control systems, or other applications whose failure can be reasonably expected to result in serious physical and/or material damage. Consult with your HUA XUAN YANG ELECTRONICS representative nearest you before using any HUA XUAN YANG ELECTRONICS products described or contained herein in such applications.
- HUA XUAN YANG ELECTRONICS assumes no responsibility for equipment failures that result from using products at values that exceed, even momentarily, rated values (such as maximum ratings, operating condition ranges, or other parameters) listed in products specifications of any and all HUA XUAN YANG ELECTRONICS products described or contained herein.
- Specifications of any and all HUA XUAN YANG ELECTRONICS products described or contained herein stipulate the performance, characteristics, and functions of the described products in the independent state, and are not guarantees of the performance, characteristics, and functions of the described products as mounted in the customer's products or equipment. To verify symptoms and states that cannot be evaluated in an independent device, the customer should always evaluate and test devices mounted in the customer's products or equipment.
- HUA XUAN YANG ELECTRONICS CO.,LTD. strives to supply high-quality high-reliability products. However, any and all semiconductor products fail with some probability. It is possible that these probabilistic failures could give rise to accidents or events that could endanger human lives, that could give rise to smoke or fire, or that could cause damage to other property. When designing equipment, adopt safety measures so that these kinds of accidents or events cannot occur. Such measures include but are not limited to protective circuits and error prevention circuits for safe design, redundant design, and structural design.
- In the event that any or all HUA XUAN YANG ELECTRONICS products(including technical data, services) described or contained herein are controlled under any of applicable local export control laws and regulations, such products must not be exported without obtaining the export license from the authorities concerned in accordance with the above law.
- No part of this publication may be reproduced or transmitted in any form or by any means, electronic or mechanical, including photocopying and recording, or any information storage or retrieval system, or otherwise, without the prior written permission of HUA XUAN YANG ELECTRONICS CO.,LTD.
- Information (including circuit diagrams and circuit parameters) herein is for example only ; it is not guaranteed for volume production. HUA XUAN YANG ELECTRONICS believes information herein is accurate and reliable, but no guarantees are made or implied regarding its use or any infringements of intellectual property rights or other rights of third parties.
- Any and all information described or contained herein are subject to change without notice due to product/technology improvement, etc. When designing equipment, refer to the "Delivery Specification" for the HUA XUAN YANG ELECTRONICS product that you intend to use.