

SN74AXC1T45 Single-Bit Dual-Supply Bus Transceiver With Configurable Voltage Translation

1 Features

- Up and Down Translation Across 0.65 V to 3.6 V
- Operating Temperature: -40°C to $+125^{\circ}\text{C}$
- Designed with glitch suppression circuitry to improve power sequencing performance
- Maximum Quiescent Current ($I_{\text{CCA}} + I_{\text{CCB}}$) of 6 μA (85°C Maximum) and 14 μA (125°C Maximum)
- Up to 500-Mbps Support When Translating from 1.8 to 3.3V
- V_{CC} Isolation Feature
 - If Either V_{CC} Input is Below 100 mV, All I/Os Outputs are Disabled and Become High-Impedance
- I_{off} Supports Partial-Power-Down Mode Operation
- Latch-Up Performance Exceeds 100 mA Per JESD 78, Class II
- ESD Protection Exceeds JESD 22
 - 8000-V Human Body Model
 - 1000-V Charged-Device Model

2 Applications

- Enterprise and Communications
- Industrial
- Personal Electronics

3 Description

The SN74AXC1T45 is a single-bit noninverting bus transceiver that uses two separate configurable power-supply rails. The device is operational with both V_{CCA} and V_{CCB} supplies as low as 0.65 V. The A port is designed to track V_{CCA} , which accepts any supply voltage from 0.65 V to 3.6 V. The B port is designed to track V_{CCB} , which also accepts any supply voltage from 0.65 V to 3.6 V.

The DIR pin determines the direction of signal propagation. With the DIR pin configured HIGH, translation is from Port A to Port B. With DIR configured LOW, translation is from Port B to Port A. The DIR pin is referenced to V_{CCA} , meaning that its logic-high and logic-low thresholds track with V_{CCA} .

This device is fully specified for partial-power-down applications using the I_{off} current. The I_{off} protection circuitry ensures that no excessive current is drawn from or to an input, output, or combined I/O that is biased to a specific voltage while the device is powered down.

The V_{CC} isolation feature ensures that if either V_{CCA} or V_{CCB} is less than 100 mV, both I/O ports enter a high-impedance state by disabling their outputs.

The glitch suppression circuitry enables either supply rail to be powered on or off in any order, providing robust power sequencing performance.

Device Information⁽¹⁾

PART NUMBER	PACKAGE	BODY SIZE (NOM)
SN74AXC1T45DBV	SOT-23 (6)	2.90 mm x 1.60 mm
SN74AXC1T45DCK	SC70 (6)	2.00 mm x 1.25 mm
SN74AXC1T45DRL	SOT-5X3 (6)	1.60 mm x 1.20 mm
SN74AXC1T45DEA	X2SON (6)	1.00 mm x 1.00 mm
SN74AXC1T45DTQ	X2SON (6)	1.00 mm x 0.80 mm

(1) For all available packages, see the orderable addendum at the end of the data sheet.

Example Application

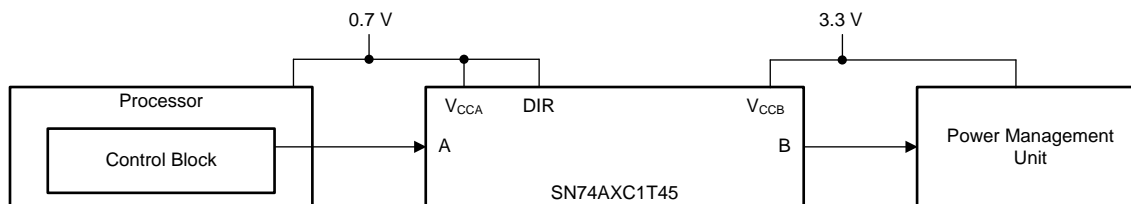

Table of Contents

1 Features	1	6.19 Switching Characteristics: $V_{CCA} = 2.5\text{ V}$, $T_A = -40^\circ\text{C}$ to $+85^\circ\text{C}$	34
2 Applications	1	6.20 Switching Characteristics: $V_{CCA} = 2.5\text{ V}$, $T_A = -40^\circ\text{C}$ to $+125^\circ\text{C}$	36
3 Description	1	6.21 Switching Characteristics: $V_{CCA} = 3.3\text{ V} \pm 0.3\text{ V}$, $T_A = -40^\circ\text{C}$ to $+85^\circ\text{C}$	38
4 Revision History	2	6.22 Switching Characteristics: $V_{CCA} = 3.3\text{ V} \pm 0.3\text{ V}$, $T_A = -40^\circ\text{C}$ to $+125^\circ\text{C}$	40
5 Pin Configuration and Functions	3	6.23 Operating Characteristics	42
6 Specifications	4	6.24 Typical Characteristics	43
6.1 Absolute Maximum Ratings	4	7 Parameter Measurement Information	45
6.2 ESD Ratings	4	7.1 Load Circuit and Voltage Waveforms	45
6.3 Recommended Operating Conditions	5	8 Detailed Description	47
6.4 Thermal Information	5	8.1 Overview	47
6.5 Electrical Characteristics: $-40^\circ\text{C} \leq T_A \leq +85^\circ\text{C}$	6	8.2 Functional Block Diagram	47
6.6 Electrical Characteristics: $-40^\circ\text{C} \leq T_A \leq +125^\circ\text{C}$	8	8.3 Feature Description	47
6.7 Switching Characteristics: $V_{CCA} = 0.7\text{ V}$, $T_A = -40^\circ\text{C}$ to $+85^\circ\text{C}$	10	8.4 Device Functional Modes	47
6.8 Switching Characteristics: $V_{CCA} = 0.7\text{ V}$, $T_A = -40^\circ\text{C}$ to $+125^\circ\text{C}$	12	9 Application and Implementation	48
6.9 Switching Characteristics: $V_{CCA} = 0.8\text{ V}$, $T_A = -40^\circ\text{C}$ to $+85^\circ\text{C}$	14	9.1 Application Information	48
6.10 Switching Characteristics: $V_{CCA} = 0.8\text{ V}$, $T_A = -40^\circ\text{C}$ to $+125^\circ\text{C}$	16	9.2 Typical Applications	48
6.11 Switching Characteristics: $V_{CCA} = 0.9\text{ V}$, $T_A = -40^\circ\text{C}$ to $+85^\circ\text{C}$	18	10 Power Supply Recommendations	52
6.12 Switching Characteristics: $V_{CCA} = 0.9\text{ V}$, $T_A = -40^\circ\text{C}$ to $+125^\circ\text{C}$	20	10.1 Power-Up Considerations	52
6.13 Switching Characteristics: $V_{CCA} = 1.2\text{ V}$, $T_A = -40^\circ\text{C}$ to $+85^\circ\text{C}$	22	11 Layout	52
6.14 Switching Characteristics: $V_{CCA} = 1.2\text{ V}$, $T_A = -40^\circ\text{C}$ to $+125^\circ\text{C}$	24	11.1 Layout Guidelines	52
6.15 Switching Characteristics: $V_{CCA} = 1.5\text{ V}$, $T_A = -40^\circ\text{C}$ to $+85^\circ\text{C}$	26	11.2 Layout Example	52
6.16 Switching Characteristics: $V_{CCA} = 1.5\text{ V}$, $T_A = -40^\circ\text{C}$ to $+125^\circ\text{C}$	28	12 Device and Documentation Support	53
6.17 Switching Characteristics: $V_{CCA} = 1.8\text{ V}$, $T_A = -40^\circ\text{C}$ to $+85^\circ\text{C}$	30	12.1 Documentation Support	53
6.18 Switching Characteristics: $V_{CCA} = 1.8\text{ V}$, $T_A = -40^\circ\text{C}$ to $+125^\circ\text{C}$	32	12.2 Receiving Notification of Documentation Updates	53
		12.3 Community Resources	53
		12.4 Trademarks	53
		12.5 Electrostatic Discharge Caution	53
		12.6 Glossary	53
		13 Mechanical, Packaging, and Orderable Information	53

4 Revision History

NOTE: Page numbers for previous revisions may differ from page numbers in the current version.

Changes from Original (April 2018) to Revision B	Page
• Added DEA and DTQ as active package options	1
• Changed product status from Production Mix to Production Data	1

Changes from Original (December 2017) to Revision A	Page
• Added pinout drawing for DEA package	3
• Added pinout drawing for DTQ package	3

5 Pin Configuration and Functions

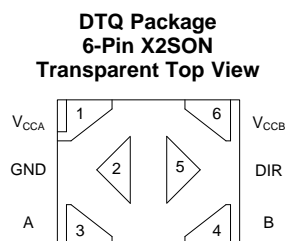
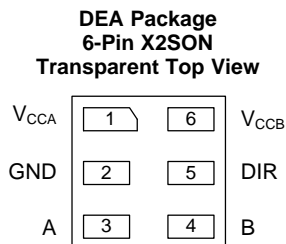
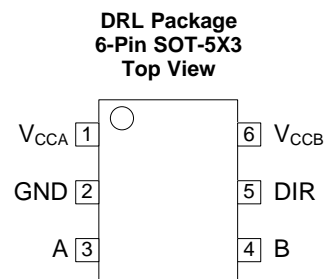
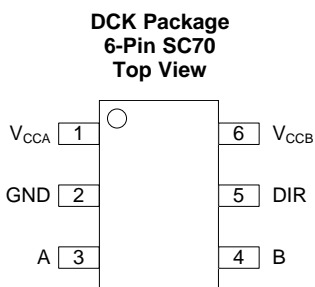
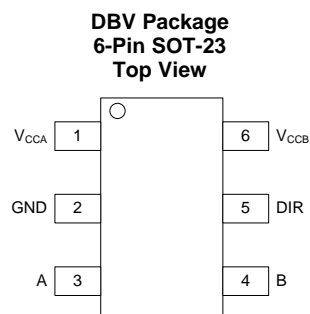

Pin Functions

PIN		TYPE	DESCRIPTION
NO.	NAME		
1	V _{CCA}	—	A-port supply voltage. $0.65V \leq V_{CCA} \leq 3.6V$
2	GND	—	Ground
3	A	I/O	Input/output A. This pin is referenced to V _{CCA} . When this pin is configured as an input, do not leave it floating.
4	B	I/O	Input/output B. This pin is referenced to V _{CCB} . When this pin is configured as an input, do not leave it floating.
5	DIR	I	Direction control signal. Set to Logic High for A-to-B level translation. Set to Logic Low for B-to-A level translation.
6	V _{CCB}	—	B-port supply voltage. $0.65V \leq V_{CCB} \leq 3.6V$.

6 Specifications

6.1 Absolute Maximum Ratings

 over operating free-air temperature range (unless otherwise noted)⁽¹⁾

		MIN	MAX	UNIT	
V _{CCA}	Supply voltage, V _{CCA}	-0.5	4.2	V	
V _{CCB}	Supply voltage, V _{CCB}	-0.5	4.2	V	
V _I	Input voltage ⁽²⁾	I/O ports (A port)	-0.5	4.2	V
		I/O ports (B port)	-0.5	4.2	
		DIR	-0.5	4.2	
V _O	Voltage applied to any output in the high-impedance or power-off state ⁽²⁾	A port	-0.5	4.2	V
		B port	-0.5	4.2	
V _O	Voltage applied to any output in the high or low state ⁽²⁾⁽³⁾	A port	-0.5	V _{CCA} + 0.2	V
		B port	-0.5	V _{CCB} + 0.2	
I _{IK}	Input clamp current	V _I < 0	-50	mA	
I _{OK}	Output clamp current	V _O < 0	-50	mA	
I _O	Continuous output current	-50	50	mA	
	Continuous current through V _{CCA} , V _{CCB} , or GND	-100	100	mA	
T _J	Operating junction temperature		150	°C	
T _{stg}	Storage temperature	-65	150	°C	

- (1) Stresses beyond those listed under the *Absolute Maximum Ratings* table may cause permanent damage to the device. These are stress ratings only, and functional operation of the device at these or any other conditions beyond those indicated under *Recommended Operating Conditions* is not implied. Exposure to absolute-maximum-rated conditions for extended periods may affect device reliability.
- (2) The input negative-voltage and output voltage ratings may be exceeded if the input and output current ratings are observed.
- (3) The output positive-voltage rating may be exceeded up to 4.2 V maximum if the output current ratings are observed.

6.2 ESD Ratings

		VALUE	UNIT
V _(ESD)	Electrostatic discharge	Human-body model (HBM), per ANSI/ESDA/JEDEC JS-001 ⁽¹⁾	±8000
		Charged-device model (CDM), per JEDEC specification JESD22-C101 ⁽²⁾	±1000

- (1) JEDEC document JEP155 states that 500-V HBM allows safe manufacturing with a standard ESD control process.
- (2) JEDEC document JEP157 states that 250-V CDM allows safe manufacturing with a standard ESD control process.

6.3 Recommended Operating Conditions

over operating free-air temperature range (unless otherwise noted)

		MIN	MAX	UNIT
V_{CCA}	Supply voltage, V_{CCA}	0.65	3.6	V
V_{CCB}	Supply voltage, V_{CCB}	0.65	3.6	V
V_I	Input voltage ⁽¹⁾⁽²⁾	0	3.6	V
V_O	Output voltage	Active state	0	V
		Tri-state	0	
$\Delta t/\Delta V$	Input transition rise or fall rate		100	ns/V
T_A	Operating free-air temperature	-40	125	°C

- (1) All unused data inputs of the device must be held at V_{CCI} or GND to assure proper device operation. For more information, refer to the [Implications of Slow or Floating CMOS Inputs application report](#).
- (2) V_{CCI} is the V_{CC} with the input port. V_{CCO} is the V_{CC} associated with the output port.

6.4 Thermal Information

THERMAL METRIC ⁽¹⁾	SN74AXC1T45					UNIT	
	DBV (SOT-23)	DCK (SC70)	DRL (SOT-5X3)	DEA (X2SON)	DTQ (X2SON)		
	6 PINS	6 PINS	6 PINS	6 PINS	6 PINS		
$R_{\theta JA}$	Junction-to-ambient thermal resistance	202.2	235.3	298.9	358.0	327.8	°C/W
$R_{\theta JC(top)}$	Junction-to-case (top) thermal resistance	137.2	160.5	148.4	201.0	194.9	°C/W
$R_{\theta JB}$	Junction-to-board thermal resistance	80.2	76.9	165.0	221.8	248.4	°C/W
Ψ_{JT}	Junction-to-top characterization parameter	64.0	59.7	20.7	26.1	24.1	°C/W
Ψ_{JB}	Junction-to-board characterization parameter	80.4	77.1	164.9	220.8	247.6	°C/W

- (1) For more information about traditional and new thermal metrics, see the [Semiconductor and IC Package Thermal Metrics application report](#).

6.5 Electrical Characteristics: $-40^{\circ}\text{C} \leq T_A \leq +85^{\circ}\text{C}$

 over recommended operating free-air temperature range (unless otherwise noted)⁽¹⁾

PARAMETER	TEST CONDITIONS ⁽²⁾⁽³⁾	MIN	MAX	UNIT
V_{IH} High-level input voltage	$V_{CCI} = 0.65\text{ V} - 0.75\text{ V}$, $V_{CCO} = 0.65\text{ V} - 3.60\text{ V}$	$V_{CCI} \times 0.70$		V
	$V_{CCI} = 0.76\text{ V} - 1\text{ V}$, $V_{CCO} = 0.65\text{ V} - 3.60\text{ V}$	$V_{CCI} \times 0.70$		
	$V_{CCI} = 1.1\text{ V} - 1.95\text{ V}$, $V_{CCO} = 0.65\text{ V} - 3.60\text{ V}$	$V_{CCI} \times 0.65$		
	$V_{CCI} = 2.3\text{ V} - 2.7\text{ V}$, $V_{CCO} = 0.65\text{ V} - 3.60\text{ V}$	1.6		
	$V_{CCI} = 3\text{ V} - 3.6\text{ V}$, $V_{CCO} = 0.65\text{ V} - 3.60\text{ V}$	2		
V_{IL} Low-level input voltage	$V_{CCI} = 0.65\text{ V} - 0.75\text{ V}$, $V_{CCO} = 0.65\text{ V} - 3.60\text{ V}$		$V_{CCI} \times 0.30$	V
	$V_{CCI} = 0.76\text{ V} - 1\text{ V}$, $V_{CCO} = 0.65\text{ V} - 3.60\text{ V}$		$V_{CCI} \times 0.30$	
	$V_{CCI} = 1.1\text{ V} - 1.95\text{ V}$, $V_{CCO} = 0.65\text{ V} - 3.60\text{ V}$		$V_{CCI} \times 0.35$	
	$V_{CCI} = 2.3\text{ V} - 2.7\text{ V}$, $V_{CCO} = 0.65\text{ V} - 3.60\text{ V}$		0.7	
	$V_{CCI} = 3\text{ V} - 3.6\text{ V}$, $V_{CCO} = 0.65\text{ V} - 3.60\text{ V}$		0.8	
V_{IH} High-level input voltage DIR	$V_{CCI} = 0.65\text{ V} - 0.75\text{ V}$, $V_{CCO} = 0.65\text{ V} - 3.60\text{ V}$	$V_{CCA} \times 0.70$		V
	$V_{CCI} = 0.76\text{ V} - 1\text{ V}$, $V_{CCO} = 0.65\text{ V} - 3.60\text{ V}$	$V_{CCA} \times 0.70$		
	$V_{CCI} = 1.1\text{ V} - 1.95\text{ V}$, $V_{CCO} = 0.65\text{ V} - 3.60\text{ V}$	$V_{CCA} \times 0.65$		
	$V_{CCI} = 2.3\text{ V} - 2.7\text{ V}$, $V_{CCO} = 0.65\text{ V} - 3.60\text{ V}$	1.6		
	$V_{CCI} = 3\text{ V} - 3.6\text{ V}$, $V_{CCO} = 0.65\text{ V} - 3.60\text{ V}$	2		
V_{IL} Low-level input voltage DIR	$V_{CCI} = 0.65\text{ V} - 0.75\text{ V}$, $V_{CCO} = 0.65\text{ V} - 3.60\text{ V}$		$V_{CCA} \times 0.30$	V
	$V_{CCI} = 0.76\text{ V} - 1\text{ V}$, $V_{CCO} = 0.65\text{ V} - 3.60\text{ V}$		$V_{CCA} \times 0.30$	
	$V_{CCI} = 1.1\text{ V} - 1.95\text{ V}$, $V_{CCO} = 0.65\text{ V} - 3.60\text{ V}$		$V_{CCA} \times 0.35$	
	$V_{CCI} = 2.3\text{ V} - 2.7\text{ V}$, $V_{CCO} = 0.65\text{ V} - 3.60\text{ V}$		0.7	
	$V_{CCI} = 3\text{ V} - 3.6\text{ V}$, $V_{CCO} = 0.65\text{ V} - 3.60\text{ V}$		0.8	
V_{OH} High-level output voltage	$V_i = V_{IH}$, $I_{OH} = -100\text{ }\mu\text{A}$, $V_{CCA} = V_{CCB}$ $V_{CCI} = 0.7\text{ V} - 3.6\text{ V}$, $V_{CCO} = 0.7\text{ V} - 3.6\text{ V}$	$V_{CCO} - 0.1$		V
	$V_i = V_{IH}$, $I_{OH} = -50\text{ }\mu\text{A}$ $V_{CCI} = 0.65\text{ V}$, $V_{CCO} = 0.65\text{ V}$	0.55		
	$V_i = V_{IH}$, $I_{OH} = -200\text{ }\mu\text{A}$ $V_{CCI} = 0.76\text{ V}$, $V_{CCO} = 0.76\text{ V}$	0.58		
	$V_i = V_{IH}$, $I_{OH} = -500\text{ }\mu\text{A}$ $V_{CCI} = 0.85\text{ V}$, $V_{CCO} = 0.85\text{ V}$	0.65		
	$V_i = V_{IH}$, $I_{OH} = -3\text{ mA}$ $V_{CCI} = 1.1\text{ V}$, $V_{CCO} = 1.1\text{ V}$	0.85		
	$V_i = V_{IH}$, $I_{OH} = -6\text{ mA}$ $V_{CCI} = 1.4\text{ V}$, $V_{CCO} = 1.4\text{ V}$	1.05		
	$V_i = V_{IH}$, $I_{OH} = -8\text{ mA}$ $V_{CCI} = 1.65\text{ V}$, $V_{CCO} = 1.65\text{ V}$	1.2		
	$V_i = V_{IH}$, $I_{OH} = -9\text{ mA}$ $V_{CCI} = 2.3\text{ V}$, $V_{CCO} = 2.3\text{ V}$	1.75		
	$V_i = V_{IH}$, $I_{OH} = -12\text{ mA}$ $V_{CCI} = 3\text{ V}$, $V_{CCO} = 3\text{ V}$	2.3		
V_{OL} Low-level output voltage	$V_i = V_{IL}$, $I_{OL} = 100\text{ }\mu\text{A}$, $V_{CCA} = V_{CCB}$ $V_{CCI} = 0.7\text{ V} - 3.6\text{ V}$, $V_{CCO} = 0.7\text{ V} - 3.6\text{ V}$		0.1	V
	$V_i = V_{IL}$, $I_{OL} = 50\text{ }\mu\text{A}$ $V_{CCI} = 0.65\text{ V}$, $V_{CCO} = 0.65\text{ V}$		0.1	
	$V_i = V_{IL}$, $I_{OL} = 200\text{ }\mu\text{A}$ $V_{CCI} = 0.76\text{ V}$, $V_{CCO} = 0.76\text{ V}$		0.18	
	$V_i = V_{IL}$, $I_{OL} = 500\text{ }\mu\text{A}$ $V_{CCI} = 0.85\text{ V}$, $V_{CCO} = 0.85\text{ V}$		0.2	
	$V_i = V_{IL}$, $I_{OL} = 3\text{ mA}$ $V_{CCI} = 1.1\text{ V}$, $V_{CCO} = 1.1\text{ V}$		0.25	
	$V_i = V_{IL}$, $I_{OL} = 6\text{ mA}$ $V_{CCI} = 1.4\text{ V}$, $V_{CCO} = 1.4\text{ V}$		0.35	
	$V_i = V_{IL}$, $I_{OL} = 8\text{ mA}$ $V_{CCI} = 1.65\text{ V}$, $V_{CCO} = 1.65\text{ V}$		0.45	
	$V_i = V_{IL}$, $I_{OL} = 9\text{ mA}$ $V_{CCI} = 2.3\text{ V}$, $V_{CCO} = 2.3\text{ V}$		0.55	
	$V_i = V_{IL}$, $I_{OL} = 12\text{ mA}$ $V_{CCI} = 3\text{ V}$, $V_{CCO} = 3\text{ V}$		0.7	
I_i Input leakage current DIR	$V_i = V_{CCA}$ or GND $V_{CCI} = 0.65\text{ V} - 3.6\text{ V}$, $V_{CCO} = 0.65\text{ V} - 3.6\text{ V}$	-1	1	μA

(1) All unused data inputs of the device must be held at V_{CCI} or GND to assure proper device operation. For more information, see the [Implications of Slow or Floating CMOS Inputs](#) application report.

(2) V_{CCI} is the V_{CC} associated with the input port.

(3) V_{CCO} is the V_{CC} associated with the output port.

Electrical Characteristics: $-40^{\circ}\text{C} \leq T_A \leq +85^{\circ}\text{C}$ (continued)

 over recommended operating free-air temperature range (unless otherwise noted)⁽¹⁾

PARAMETER	TEST CONDITIONS ⁽²⁾⁽³⁾	MIN	MAX	UNIT
I_{off} Off-state current	A port: V_I or $V_O = 0$ to 3.6 V $V_{\text{CCI}} = 0$ V, $V_{\text{CCO}} = 0 - 3.6$ V	-5	5	μA
	B port: V_I or $V_O = 0$ to 3.6 V $V_{\text{CCI}} = 0 - 3.6$ V, $V_{\text{CCO}} = 0$ V	-5	5	
I_{OZ} High-impedance-state output current	B port: $V_O = V_{\text{CCO}}$ or GND, $V_I = V_{\text{CCI}}$ or GND $V_{\text{CCI}} = 0$ V, $V_{\text{CCO}} = 3.6$ V	-5	5	μA
	A port: $V_O = V_{\text{CCO}}$ or GND, $V_I = V_{\text{CCI}}$ or GND $V_{\text{CCI}} = 3.6$ V, $V_{\text{CCO}} = 0$ V	-5	5	
I_{CCA} V_{CCA} supply current	$V_I = V_{\text{CCI}}$ or GND, $I_O = 0$ $V_{\text{CCI}} = 0.65$ V – 3.6 V, $V_{\text{CCO}} = 0.65$ V – 3.6 V		6	μA
	$V_I = V_{\text{CCI}}$ or GND, $I_O = 0$ $V_{\text{CCI}} = 0$ V, $V_{\text{CCO}} = 3.6$ V	-2		
	$V_I = V_{\text{CCI}}$ or GND, $I_O = 0$ $V_{\text{CCI}} = 3.6$ V, $V_{\text{CCO}} = 0$ V		2	
I_{CCB} V_{CCB} supply current	$V_I = V_{\text{CCI}}$ or GND, $I_O = 0$ $V_{\text{CCI}} = 0.65$ V – 3.6 V, $V_{\text{CCO}} = 0.65$ V – 3.6 V		6	μA
	$V_I = V_{\text{CCI}}$ or GND, $I_O = 0$ $V_{\text{CCI}} = 0$ V, $V_{\text{CCO}} = 3.6$ V		2	
	$V_I = V_{\text{CCI}}$ or GND, $I_O = 0$ $V_{\text{CCI}} = 3.6$ V, $V_{\text{CCO}} = 0$ V	-2		
I_{CCA} + I_{CCB} Combined supply current	$V_I = V_{\text{CCI}}$ or GND, $I_O = 0$ $V_{\text{CCI}} = 0.65$ V – 3.6 V, $V_{\text{CCO}} = 0.65$ V – 3.6 V		6	μA
C_i Input capacitance DIR	$V_I = 0$ V, 3.30 V $V_{\text{CCI}} = 3.3$ V, $V_{\text{CCO}} = 3.3$ V		4.4	pF
$C_{i/O}$ Input-to-output internal capacitance	A Port: $V_O = 1.65$ V DC + 1 MHz, -16-dBm sine wave $V_{\text{CCI}} = 3.3$ V, $V_{\text{CCO}} = 0$ V		5	pF
$C_{i/O}$ Input-to-output internal capacitance	B Port: $V_O = 1.65$ V DC + 1 MHz, -16-dBm sine wave $V_{\text{CCI}} = 0$ V, $V_{\text{CCO}} = 3.3$ V		5	pF

6.6 Electrical Characteristics: $-40^{\circ}\text{C} \leq T_A \leq +125^{\circ}\text{C}$

 over recommended operating free-air temperature range (unless otherwise noted)⁽¹⁾

PARAMETER	TEST CONDITIONS ^{(2) (3)}	MIN	MAX	UNIT
V_{IH} High-level input voltage	$V_{CCI} = 0.65\text{ V} - 0.75\text{ V}, V_{CCO} = 0.65\text{ V} - 3.60\text{ V}$	$V_{CCI} \times 0.70$		V
	$V_{CCI} = 0.76\text{ V} - 1\text{ V}, V_{CCO} = 0.65\text{ V} - 3.60\text{ V}$	$V_{CCI} \times 0.70$		
	$V_{CCI} = 1.1\text{ V} - 1.95\text{ V}, V_{CCO} = 0.65\text{ V} - 3.60\text{ V}$	$V_{CCI} \times 0.65$		
	$V_{CCI} = 2.3\text{ V} - 2.7\text{ V}, V_{CCO} = 0.65\text{ V} - 3.60\text{ V}$	1.6		
	$V_{CCI} = 3\text{ V} - 3.6\text{ V}, V_{CCO} = 0.65\text{ V} - 3.60\text{ V}$	2		
V_{IL} Low-level input voltage	$V_{CCI} = 0.65\text{ V} - 0.75\text{ V}, V_{CCO} = 0.65\text{ V} - 3.60\text{ V}$		$V_{CCI} \times 0.30$	V
	$V_{CCI} = 0.76\text{ V} - 1\text{ V}, V_{CCO} = 0.65\text{ V} - 3.60\text{ V}$		$V_{CCI} \times 0.30$	
	$V_{CCI} = 1.1\text{ V} - 1.95\text{ V}, V_{CCO} = 0.65\text{ V} - 3.60\text{ V}$		$V_{CCI} \times 0.35$	
	$V_{CCI} = 2.3\text{ V} - 2.7\text{ V}, V_{CCO} = 0.65\text{ V} - 3.60\text{ V}$		0.7	
	$V_{CCI} = 3\text{ V} - 3.6\text{ V}, V_{CCO} = 0.65\text{ V} - 3.60\text{ V}$		0.8	
V_{IH} High-level input voltage DIR	$V_{CCI} = 0.65\text{ V} - 0.75\text{ V}, V_{CCO} = 0.65\text{ V} - 3.60\text{ V}$	$V_{CCA} \times 0.70$		V
	$V_{CCI} = 0.76\text{ V} - 1\text{ V}, V_{CCO} = 0.65\text{ V} - 3.60\text{ V}$	$V_{CCA} \times 0.70$		
	$V_{CCI} = 1.1\text{ V} - 1.95\text{ V}, V_{CCO} = 0.65\text{ V} - 3.60\text{ V}$	$V_{CCA} \times 0.65$		
	$V_{CCI} = 2.3\text{ V} - 2.7\text{ V}, V_{CCO} = 0.65\text{ V} - 3.60\text{ V}$	1.6		
	$V_{CCI} = 3\text{ V} - 3.6\text{ V}, V_{CCO} = 0.65\text{ V} - 3.60\text{ V}$	2		
V_{IL} Low-level input voltage DIR	$V_{CCI} = 0.65\text{ V} - 0.75\text{ V}, V_{CCO} = 0.65\text{ V} - 3.60\text{ V}$		$V_{CCA} \times 0.30$	V
	$V_{CCI} = 0.76\text{ V} - 1\text{ V}, V_{CCO} = 0.65\text{ V} - 3.60\text{ V}$		$V_{CCA} \times 0.30$	
	$V_{CCI} = 1.1\text{ V} - 1.95\text{ V}, V_{CCO} = 0.65\text{ V} - 3.60\text{ V}$		$V_{CCA} \times 0.35$	
	$V_{CCI} = 2.3\text{ V} - 2.7\text{ V}, V_{CCO} = 0.65\text{ V} - 3.60\text{ V}$		0.7	
	$V_{CCI} = 3\text{ V} - 3.6\text{ V}, V_{CCO} = 0.65\text{ V} - 3.60\text{ V}$		0.8	
V_{OH} High-level output voltage	$V_I = V_{IH}, I_{OH} = -100\text{ }\mu\text{A}, V_{CCA} = V_{CCB}$ $V_{CCI} = 0.7\text{ V} - 3.6\text{ V}, V_{CCO} = 0.7\text{ V} - 3.6\text{ V}$	$V_{CCO} - 0.1$		V
	$V_I = V_{IH}, I_{OH} = -50\text{ }\mu\text{A}$ $V_{CCI} = 0.65\text{ V}, V_{CCO} = 0.65\text{ V}$	0.55		
	$V_I = V_{IH}, I_{OH} = -200\text{ }\mu\text{A}$ $V_{CCI} = 0.76\text{ V}, V_{CCO} = 0.76\text{ V}$	0.58		
	$V_I = V_{IH}, I_{OH} = -500\text{ }\mu\text{A}$ $V_{CCI} = 0.85\text{ V}, V_{CCO} = 0.85\text{ V}$	0.65		
	$V_I = V_{IH}, I_{OH} = -3\text{ mA}$ $V_{CCI} = 1.1\text{ V}, V_{CCO} = 1.1\text{ V}$	0.85		
	$V_I = V_{IH}, I_{OH} = -6\text{ mA}$ $V_{CCI} = 1.4\text{ V}, V_{CCO} = 1.4\text{ V}$	1.05		
	$V_I = V_{IH}, I_{OH} = -8\text{ mA}$ $V_{CCI} = 1.65\text{ V}, V_{CCO} = 1.65\text{ V}$	1.2		
	$V_I = V_{IH}, I_{OH} = -9\text{ mA}$ $V_{CCI} = 2.3\text{ V}, V_{CCO} = 2.3\text{ V}$	1.75		
	$V_I = V_{IH}, I_{OH} = -12\text{ mA}$ $V_{CCI} = 3\text{ V}, V_{CCO} = 3\text{ V}$	2.3		
V_{OL} Low-level output voltage	$V_I = V_{IL}, I_{OL} = 100\text{ }\mu\text{A}, V_{CCA} = V_{CCB}$ $V_{CCI} = 0.7\text{ V} - 3.6\text{ V}, V_{CCO} = 0.7\text{ V} - 3.6\text{ V}$		0.1	V
	$V_I = V_{IL}, I_{OL} = 50\text{ }\mu\text{A}$ $V_{CCI} = 0.65\text{ V}, V_{CCO} = 0.65\text{ V}$		0.1	
	$V_I = V_{IL}, I_{OL} = 200\text{ }\mu\text{A}$ $V_{CCI} = 0.76\text{ V}, V_{CCO} = 0.76\text{ V}$		0.18	
	$V_I = V_{IL}, I_{OL} = 500\text{ }\mu\text{A}$ $V_{CCI} = 0.85\text{ V}, V_{CCO} = 0.85\text{ V}$		0.2	
	$V_I = V_{IL}, I_{OL} = 3\text{ mA}$ $V_{CCI} = 1.1\text{ V}, V_{CCO} = 1.1\text{ V}$		0.25	
	$V_I = V_{IL}, I_{OL} = 6\text{ mA}$ $V_{CCI} = 1.4\text{ V}, V_{CCO} = 1.4\text{ V}$		0.35	
	$V_I = V_{IL}, I_{OL} = 8\text{ mA}$ $V_{CCI} = 1.65\text{ V}, V_{CCO} = 1.65\text{ V}$		0.45	
	$V_I = V_{IL}, I_{OL} = 9\text{ mA}$ $V_{CCI} = 2.3\text{ V}, V_{CCO} = 2.3\text{ V}$		0.55	
$V_I = V_{IL}, I_{OL} = 12\text{ mA}$ $V_{CCI} = 3\text{ V}, V_{CCO} = 3\text{ V}$		0.7		
I_I Input leakage current DIR	$V_I = V_{CCA}$ or GND $V_{CCI} = 0.65\text{ V} - 3.6\text{ V}, V_{CCO} = 0.65\text{ V} - 3.6\text{ V}$	-1.5	1.5	μA

(1) All unused data inputs of the device must be held at V_{CCI} or GND to assure proper device operation. For more information, see the [Implications of Slow or Floating CMOS Inputs](#) application report.

(2) V_{CCI} is the V_{CC} associated with the input port.

(3) V_{CCO} is the V_{CC} associated with the output port.

Electrical Characteristics: $-40^{\circ}\text{C} \leq T_A \leq +125^{\circ}\text{C}$ (continued)

 over recommended operating free-air temperature range (unless otherwise noted)⁽¹⁾

PARAMETER	TEST CONDITIONS ⁽²⁾ ⁽³⁾	MIN	MAX	UNIT
I_{off} Off-state current	A port: V_I or $V_O = 0$ to 3.6 V $V_{\text{CCI}} = 0$ V, $V_{\text{CCO}} = 0 - 3.6$ V	-7.5	7.5	μA
	B port: V_I or $V_O = 0$ to 3.6 V $V_{\text{CCI}} = 0 - 3.6$ V, $V_{\text{CCO}} = 0$ V	-7.5	7.5	
I_{OZ} High-impedance-state output current	B port: $V_O = V_{\text{CCO}}$ or GND, $V_I = V_{\text{CCI}}$ or GND $V_{\text{CCI}} = 0$ V, $V_{\text{CCO}} = 3.6$ V	-7.5	7.5	μA
	A port: $V_O = V_{\text{CCO}}$ or GND, $V_I = V_{\text{CCI}}$ or GND $V_{\text{CCI}} = 3.6$ V, $V_{\text{CCO}} = 0$ V	-7.5	7.5	
I_{CCA} V_{CCA} supply current	$V_I = V_{\text{CCI}}$ or GND, $I_O = 0$ $V_{\text{CCI}} = 0.65$ V – 3.6 V, $V_{\text{CCO}} = 0.65$ V – 3.6 V		8	μA
	$V_I = V_{\text{CCI}}$ or GND, $I_O = 0$ $V_{\text{CCI}} = 0$ V, $V_{\text{CCO}} = 3.6$ V	-8		
	$V_I = V_{\text{CCI}}$ or GND, $I_O = 0$ $V_{\text{CCI}} = 3.6$ V, $V_{\text{CCO}} = 0$ V		8	
I_{CCB} V_{CCB} supply current	$V_I = V_{\text{CCI}}$ or GND, I_O $V_{\text{CCI}} = 0.65$ V – 3.6 V, $V_{\text{CCO}} = 0.65$ V – 3.6 V		8.5	μA
	$V_I = V_{\text{CCI}}$ or GND, I_O $V_{\text{CCI}} = 0$ V, $V_{\text{CCO}} = 3.6$ V		8	
	$V_I = V_{\text{CCI}}$ or GND, I_O $V_{\text{CCI}} = 3.6$ V, $V_{\text{CCO}} = 0$ V	-8		
$I_{\text{CCA}} + I_{\text{CCB}}$ Combined supply current	$V_I = V_{\text{CCI}}$ or GND, $I_O = 0$ $V_{\text{CCI}} = 0.65$ V – 3.6 V, $V_{\text{CCO}} = 0.65$ V – 3.6 V		14	μA
C_I Input capacitance DIR	$V_I = 0$ V, 3.30V $V_{\text{CCI}} = 3.3$ V, $V_{\text{CCO}} = 3.3$ V		4.4	pF
C_{IO} Input-to-output internal capacitance	A Port: $V_O = 1.65$ V DC + 1 MHz, -16-dBm sine wave $V_{\text{CCI}} = 3.3$ V, $V_{\text{CCO}} = 0$ V		5	pF
C_{IO} Input-to-output internal capacitance	B Port: $V_O = 1.65$ V DC + 1 MHz, -16-dBm sine wave $V_{\text{CCI}} = 0$ V, $V_{\text{CCO}} = 3.3$ V		5	pF

6.7 Switching Characteristics: $V_{CCA} = 0.7\text{ V}$, $T_A = -40^\circ\text{C}$ to $+85^\circ\text{C}$

 over recommended operating free-air temperature range, $V_{CCA} = 0.7\text{ V}$ (see [Figure 1](#))

PARAMETER		TEST CONDITIONS	MIN	MAX	UNIT	
t_{pd}	Propagation delay	A-to-B	$V_{CCB} = 0.7\text{ V} \pm 0.05\text{ V}$	0.5	173	ns
			$V_{CCB} = 0.8\text{ V} \pm 0.04\text{ V}$	0.5	117	
			$V_{CCB} = 0.9\text{ V} \pm 0.045\text{ V}$	0.5	85	
			$V_{CCB} = 1.2\text{ V} \pm 0.1\text{ V}$	0.5	51	
			$V_{CCB} = 1.5\text{ V} \pm 0.1\text{ V}$	0.5	50	
			$V_{CCB} = 1.8\text{ V} \pm 0.15\text{ V}$	0.5	53	
			$V_{CCB} = 2.5\text{ V} \pm 0.2\text{ V}$	0.5	65	
			$V_{CCB} = 3.3\text{ V} \pm 0.3\text{ V}$	0.5	143	
	B-to-A	$V_{CCB} = 0.7\text{ V} \pm 0.05\text{ V}$	0.5	173	ns	
		$V_{CCB} = 0.8\text{ V} \pm 0.04\text{ V}$	0.5	154		
		$V_{CCB} = 0.9\text{ V} \pm 0.045\text{ V}$	0.5	127		
		$V_{CCB} = 1.2\text{ V} \pm 0.1\text{ V}$	0.5	88		
		$V_{CCB} = 1.5\text{ V} \pm 0.1\text{ V}$	0.5	83		
		$V_{CCB} = 1.8\text{ V} \pm 0.15\text{ V}$	0.5	82		
$V_{CCB} = 2.5\text{ V} \pm 0.2\text{ V}$		0.5	80			
$V_{CCB} = 3.3\text{ V} \pm 0.3\text{ V}$		0.5	80			
t_{dis}	Disable time	Port A	$V_{CCB} = 0.7\text{ V} \pm 0.05\text{ V}$	0.5	143	ns
			$V_{CCB} = 0.8\text{ V} \pm 0.04\text{ V}$	0.5	143	
			$V_{CCB} = 0.9\text{ V} \pm 0.045\text{ V}$	0.5	143	
			$V_{CCB} = 1.2\text{ V} \pm 0.1\text{ V}$	0.5	143	
			$V_{CCB} = 1.5\text{ V} \pm 0.1\text{ V}$	0.5	143	
			$V_{CCB} = 1.8\text{ V} \pm 0.15\text{ V}$	0.5	143	
			$V_{CCB} = 2.5\text{ V} \pm 0.2\text{ V}$	0.5	143	
			$V_{CCB} = 3.3\text{ V} \pm 0.3\text{ V}$	0.5	143	
	Port B	$V_{CCB} = 0.7\text{ V} \pm 0.05\text{ V}$	0.5	163	ns	
		$V_{CCB} = 0.8\text{ V} \pm 0.04\text{ V}$	0.5	123		
		$V_{CCB} = 0.9\text{ V} \pm 0.045\text{ V}$	0.5	100		
		$V_{CCB} = 1.2\text{ V} \pm 0.1\text{ V}$	0.5	50		
		$V_{CCB} = 1.5\text{ V} \pm 0.1\text{ V}$	0.5	45		
		$V_{CCB} = 1.8\text{ V} \pm 0.15\text{ V}$	0.5	49		
$V_{CCB} = 2.5\text{ V} \pm 0.2\text{ V}$		0.5	61			
$V_{CCB} = 3.3\text{ V} \pm 0.3\text{ V}$		0.5	109			

Switching Characteristics: $V_{CCA} = 0.7\text{ V}$, $T_A = -40^\circ\text{C}$ to $+85^\circ\text{C}$ (continued)

 over recommended operating free-air temperature range, $V_{CCA} = 0.7\text{ V}$ (see [Figure 1](#))

PARAMETER	TEST CONDITIONS		MIN	MAX	UNIT
t_{en} Enable time	Port A	$V_{CCB} = 0.7\text{ V} \pm 0.05\text{ V}$		389	ns
		$V_{CCB} = 0.8\text{ V} \pm 0.04\text{ V}$		331	
		$V_{CCB} = 0.9\text{ V} \pm 0.045\text{ V}$		287	
		$V_{CCB} = 1.2\text{ V} \pm 0.1\text{ V}$		143	
		$V_{CCB} = 1.5\text{ V} \pm 0.1\text{ V}$		134	
		$V_{CCB} = 1.8\text{ V} \pm 0.15\text{ V}$		137	
		$V_{CCB} = 2.5\text{ V} \pm 0.2\text{ V}$		147	
		$V_{CCB} = 3.3\text{ V} \pm 0.3\text{ V}$		200	
	Port B	$V_{CCB} = 0.7\text{ V} \pm 0.05\text{ V}$		369	ns
		$V_{CCB} = 0.8\text{ V} \pm 0.04\text{ V}$		313	
		$V_{CCB} = 0.9\text{ V} \pm 0.045\text{ V}$		281	
		$V_{CCB} = 1.2\text{ V} \pm 0.1\text{ V}$		247	
		$V_{CCB} = 1.5\text{ V} \pm 0.1\text{ V}$		246	
		$V_{CCB} = 1.8\text{ V} \pm 0.15\text{ V}$		249	
		$V_{CCB} = 2.5\text{ V} \pm 0.2\text{ V}$		261	
		$V_{CCB} = 3.3\text{ V} \pm 0.3\text{ V}$		339	

6.8 Switching Characteristics: $V_{CCB} = 0.7\text{ V}$, $T_A = -40^\circ\text{C}$ to $+125^\circ\text{C}$

 over recommended operating free-air temperature range, $V_{CCA} = 0.7\text{ V}$ (see [Figure 9](#))

PARAMETER	TEST CONDITIONS		MIN	MAX	UNIT
t_{pd} Propagation delay	A-to-B	$V_{CCB} = 0.7\text{ V} \pm 0.05\text{ V}$	0.5	173	ns
		$V_{CCB} = 0.8\text{ V} \pm 0.04\text{ V}$	0.5	117	
		$V_{CCB} = 0.9\text{ V} \pm 0.045\text{ V}$	0.5	85	
		$V_{CCB} = 1.2\text{ V} \pm 0.1\text{ V}$	0.5	51	
		$V_{CCB} = 1.5\text{ V} \pm 0.1\text{ V}$	0.5	50	
		$V_{CCB} = 1.8\text{ V} \pm 0.15\text{ V}$	0.5	53	
		$V_{CCB} = 2.5\text{ V} \pm 0.2\text{ V}$	0.5	65	
	B-to-A	$V_{CCB} = 0.7\text{ V} \pm 0.05\text{ V}$	0.5	173	ns
		$V_{CCB} = 0.8\text{ V} \pm 0.04\text{ V}$	0.5	154	
		$V_{CCB} = 0.9\text{ V} \pm 0.045\text{ V}$	0.5	127	
		$V_{CCB} = 1.2\text{ V} \pm 0.1\text{ V}$	0.5	88	
		$V_{CCB} = 1.5\text{ V} \pm 0.1\text{ V}$	0.5	83	
		$V_{CCB} = 1.8\text{ V} \pm 0.15\text{ V}$	0.5	82	
		$V_{CCB} = 2.5\text{ V} \pm 0.2\text{ V}$	0.5	80	
t_{dis} Disable time	Port A	$V_{CCB} = 0.7\text{ V} \pm 0.05\text{ V}$	0.5	143	ns
		$V_{CCB} = 0.8\text{ V} \pm 0.04\text{ V}$	0.5	143	
		$V_{CCB} = 0.9\text{ V} \pm 0.045\text{ V}$	0.5	143	
		$V_{CCB} = 1.2\text{ V} \pm 0.1\text{ V}$	0.5	143	
		$V_{CCB} = 1.5\text{ V} \pm 0.1\text{ V}$	0.5	143	
		$V_{CCB} = 1.8\text{ V} \pm 0.15\text{ V}$	0.5	143	
		$V_{CCB} = 2.5\text{ V} \pm 0.2\text{ V}$	0.5	143	
	Port B	$V_{CCB} = 0.7\text{ V} \pm 0.05\text{ V}$	0.5	163	ns
		$V_{CCB} = 0.8\text{ V} \pm 0.04\text{ V}$	0.5	123	
		$V_{CCB} = 0.9\text{ V} \pm 0.045\text{ V}$	0.5	100	
		$V_{CCB} = 1.2\text{ V} \pm 0.1\text{ V}$	0.5	50	
		$V_{CCB} = 1.5\text{ V} \pm 0.1\text{ V}$	0.5	45	
		$V_{CCB} = 1.8\text{ V} \pm 0.15\text{ V}$	0.5	49	
		$V_{CCB} = 2.5\text{ V} \pm 0.2\text{ V}$	0.5	161	
	$V_{CCB} = 3.3\text{ V} \pm 0.3\text{ V}$	0.5	109		

Switching Characteristics: $V_{CCA} = 0.7\text{ V}$, $T_A = -40^\circ\text{C}$ to $+125^\circ\text{C}$ (continued)

 over recommended operating free-air temperature range, $V_{CCA} = 0.7\text{ V}$ (see [Figure 9](#))

PARAMETER	TEST CONDITIONS		MIN	MAX	UNIT
t_{en} Enable time	Port A	$V_{CCB} = 0.7\text{ V} \pm 0.05\text{ V}$		406	ns
		$V_{CCB} = 0.8\text{ V} \pm 0.04\text{ V}$		333	
		$V_{CCB} = 0.9\text{ V} \pm 0.045\text{ V}$		287	
		$V_{CCB} = 1.2\text{ V} \pm 0.1\text{ V}$		143	
		$V_{CCB} = 1.5\text{ V} \pm 0.1\text{ V}$		134	
		$V_{CCB} = 1.8\text{ V} \pm 0.15\text{ V}$		137	
		$V_{CCB} = 2.5\text{ V} \pm 0.2\text{ V}$		147	
		$V_{CCB} = 3.3\text{ V} \pm 0.3\text{ V}$		200	
	Port B	$V_{CCB} = 0.7\text{ V} \pm 0.05\text{ V}$		395	ns
		$V_{CCB} = 0.8\text{ V} \pm 0.04\text{ V}$		339	
		$V_{CCB} = 0.9\text{ V} \pm 0.045\text{ V}$		307	
		$V_{CCB} = 1.2\text{ V} \pm 0.1\text{ V}$		273	
		$V_{CCB} = 1.5\text{ V} \pm 0.1\text{ V}$		272	
		$V_{CCB} = 1.8\text{ V} \pm 0.15\text{ V}$		275	
		$V_{CCB} = 2.5\text{ V} \pm 0.2\text{ V}$		287	
		$V_{CCB} = 3.3\text{ V} \pm 0.3\text{ V}$		365	

6.9 Switching Characteristics: $V_{CCA} = 0.8\text{ V}$, $T_A = -40^\circ\text{C}$ to $+85^\circ\text{C}$

 over recommended operating free-air temperature range, $V_{CCA} = 0.8\text{ V}$ (see [Figure 2](#))

PARAMETER	TEST CONDITIONS		MIN	MAX	UNIT
t_{pd} Propagation delay	A-to-B	$V_{CCB} = 0.7\text{ V} \pm 0.05\text{ V}$	0.5	153	ns
		$V_{CCB} = 0.8\text{ V} \pm 0.04\text{ V}$	0.5	95	
		$V_{CCB} = 0.9\text{ V} \pm 0.045\text{ V}$	0.5	64	
		$V_{CCB} = 1.2\text{ V} \pm 0.1\text{ V}$	0.5	33	
		$V_{CCB} = 1.5\text{ V} \pm 0.1\text{ V}$	0.5	27	
		$V_{CCB} = 1.8\text{ V} \pm 0.15\text{ V}$	0.5	26	
		$V_{CCB} = 2.5\text{ V} \pm 0.2\text{ V}$	0.5	27	
		$V_{CCB} = 3.3\text{ V} \pm 0.3\text{ V}$	0.5	36	
	B-to-A	$V_{CCB} = 0.7\text{ V} \pm 0.05\text{ V}$	0.5	117	ns
		$V_{CCB} = 0.8\text{ V} \pm 0.04\text{ V}$	0.5	96	
		$V_{CCB} = 0.9\text{ V} \pm 0.045\text{ V}$	0.5	78	
		$V_{CCB} = 1.2\text{ V} \pm 0.1\text{ V}$	0.5	52	
		$V_{CCB} = 1.5\text{ V} \pm 0.1\text{ V}$	0.5	42	
		$V_{CCB} = 1.8\text{ V} \pm 0.15\text{ V}$	0.5	41	
$V_{CCB} = 2.5\text{ V} \pm 0.2\text{ V}$		0.5	40		
$V_{CCB} = 3.3\text{ V} \pm 0.3\text{ V}$		0.5	39		
t_{dis} Disable time	Port A	$V_{CCB} = 0.7\text{ V} \pm 0.05\text{ V}$	0.5	100	ns
		$V_{CCB} = 0.8\text{ V} \pm 0.04\text{ V}$	0.5	100	
		$V_{CCB} = 0.9\text{ V} \pm 0.045\text{ V}$	0.5	100	
		$V_{CCB} = 1.2\text{ V} \pm 0.1\text{ V}$	0.5	100	
		$V_{CCB} = 1.5\text{ V} \pm 0.1\text{ V}$	0.5	100	
		$V_{CCB} = 1.8\text{ V} \pm 0.15\text{ V}$	0.5	100	
		$V_{CCB} = 2.5\text{ V} \pm 0.2\text{ V}$	0.5	100	
		$V_{CCB} = 3.3\text{ V} \pm 0.3\text{ V}$	0.5	100	
	Port B	$V_{CCB} = 0.7\text{ V} \pm 0.05\text{ V}$	0.5	151	ns
		$V_{CCB} = 0.8\text{ V} \pm 0.04\text{ V}$	0.5	111	
		$V_{CCB} = 0.9\text{ V} \pm 0.045\text{ V}$	0.5	88	
		$V_{CCB} = 1.2\text{ V} \pm 0.1\text{ V}$	0.5	38	
		$V_{CCB} = 1.5\text{ V} \pm 0.1\text{ V}$	0.5	32	
		$V_{CCB} = 1.8\text{ V} \pm 0.15\text{ V}$	0.5	30	
$V_{CCB} = 2.5\text{ V} \pm 0.2\text{ V}$		0.5	30		
$V_{CCB} = 3.3\text{ V} \pm 0.3\text{ V}$		0.5	38		

Switching Characteristics: $V_{CCA} = 0.8\text{ V}$, $T_A = -40^\circ\text{C}$ to $+85^\circ\text{C}$ (continued)

 over recommended operating free-air temperature range, $V_{CCA} = 0.8\text{ V}$ (see [Figure 2](#))

PARAMETER	TEST CONDITIONS		MIN	MAX	UNIT
t_{en} Enable time	Port A	$V_{CCB} = 0.7\text{ V} \pm 0.05\text{ V}$		321	ns
		$V_{CCB} = 0.8\text{ V} \pm 0.04\text{ V}$		261	
		$V_{CCB} = 0.9\text{ V} \pm 0.045\text{ V}$		226	
		$V_{CCB} = 1.2\text{ V} \pm 0.1\text{ V}$		96	
		$V_{CCB} = 1.5\text{ V} \pm 0.1\text{ V}$		80	
		$V_{CCB} = 1.8\text{ V} \pm 0.15\text{ V}$		78	
		$V_{CCB} = 2.5\text{ V} \pm 0.2\text{ V}$		76	
		$V_{CCB} = 3.3\text{ V} \pm 0.3\text{ V}$		87	
	Port B	$V_{CCB} = 0.7\text{ V} \pm 0.05\text{ V}$		309	ns
		$V_{CCB} = 0.8\text{ V} \pm 0.04\text{ V}$		251	
		$V_{CCB} = 0.9\text{ V} \pm 0.045\text{ V}$		220	
		$V_{CCB} = 1.2\text{ V} \pm 0.1\text{ V}$		189	
		$V_{CCB} = 1.5\text{ V} \pm 0.1\text{ V}$		183	
		$V_{CCB} = 1.8\text{ V} \pm 0.15\text{ V}$		182	
		$V_{CCB} = 2.5\text{ V} \pm 0.2\text{ V}$		183	
		$V_{CCB} = 3.3\text{ V} \pm 0.3\text{ V}$		192	

6.10 Switching Characteristics: $V_{CCA} = 0.8\text{ V}$, $T_A = -40^\circ\text{C}$ to $+125^\circ\text{C}$

 over recommended operating free-air temperature range, $V_{CCA} = 0.8\text{ V}$ (see [Figure 10](#))

PARAMETER	TEST CONDITIONS		MIN	MAX	UNIT
t_{pd} Propagation delay	A-to-B	$V_{CCB} = 0.7\text{ V} \pm 0.05\text{ V}$	0.5	153	ns
		$V_{CCB} = 0.8\text{ V} \pm 0.04\text{ V}$	0.5	95	
		$V_{CCB} = 0.9\text{ V} \pm 0.045\text{ V}$	0.5	64	
		$V_{CCB} = 1.2\text{ V} \pm 0.1\text{ V}$	0.5	33	
		$V_{CCB} = 1.5\text{ V} \pm 0.1\text{ V}$	0.5	27	
		$V_{CCB} = 1.8\text{ V} \pm 0.15\text{ V}$	0.5	26	
		$V_{CCB} = 2.5\text{ V} \pm 0.2\text{ V}$	0.5	27	
		$V_{CCB} = 3.3\text{ V} \pm 0.3\text{ V}$	0.5	36	
	B-to-A	$V_{CCB} = 0.7\text{ V} \pm 0.05\text{ V}$	0.5	117	ns
		$V_{CCB} = 0.8\text{ V} \pm 0.04\text{ V}$	0.5	96	
		$V_{CCB} = 0.9\text{ V} \pm 0.045\text{ V}$	0.5	78	
		$V_{CCB} = 1.2\text{ V} \pm 0.1\text{ V}$	0.5	52	
		$V_{CCB} = 1.5\text{ V} \pm 0.1\text{ V}$	0.5	42	
		$V_{CCB} = 1.8\text{ V} \pm 0.15\text{ V}$	0.5	41	
$V_{CCB} = 2.5\text{ V} \pm 0.2\text{ V}$		0.5	40		
$V_{CCB} = 3.3\text{ V} \pm 0.3\text{ V}$		0.5	39		
t_{dis} Disable time	Port A	$V_{CCB} = 0.7\text{ V} \pm 0.05\text{ V}$	0.5	100	ns
		$V_{CCB} = 0.8\text{ V} \pm 0.04\text{ V}$	0.5	100	
		$V_{CCB} = 0.9\text{ V} \pm 0.045\text{ V}$	0.5	100	
		$V_{CCB} = 1.2\text{ V} \pm 0.1\text{ V}$	0.5	100	
		$V_{CCB} = 1.5\text{ V} \pm 0.1\text{ V}$	0.5	100	
		$V_{CCB} = 1.8\text{ V} \pm 0.15\text{ V}$	0.5	100	
		$V_{CCB} = 2.5\text{ V} \pm 0.2\text{ V}$	0.5	100	
		$V_{CCB} = 3.3\text{ V} \pm 0.3\text{ V}$	0.5	100	
	Port B	$V_{CCB} = 0.7\text{ V} \pm 0.05\text{ V}$	0.5	151	ns
		$V_{CCB} = 0.8\text{ V} \pm 0.04\text{ V}$	0.5	111	
		$V_{CCB} = 0.9\text{ V} \pm 0.045\text{ V}$	0.5	88	
		$V_{CCB} = 1.2\text{ V} \pm 0.1\text{ V}$	0.5	40	
		$V_{CCB} = 1.5\text{ V} \pm 0.1\text{ V}$	0.5	33	
		$V_{CCB} = 1.8\text{ V} \pm 0.15\text{ V}$	0.5	30	
$V_{CCB} = 2.5\text{ V} \pm 0.2\text{ V}$		0.5	30		
$V_{CCB} = 3.3\text{ V} \pm 0.3\text{ V}$		0.5	38		

Switching Characteristics: $V_{CCA} = 0.8\text{ V}$, $T_A = -40^\circ\text{C}$ to $+125^\circ\text{C}$ (continued)

 over recommended operating free-air temperature range, $V_{CCA} = 0.8\text{ V}$ (see [Figure 10](#))

PARAMETER	TEST CONDITIONS		MIN	MAX	UNIT
t_{en} Enable time	Port A	$V_{CCB} = 0.7\text{ V} \pm 0.05\text{ V}$		341	ns
		$V_{CCB} = 0.8\text{ V} \pm 0.04\text{ V}$		266	
		$V_{CCB} = 0.9\text{ V} \pm 0.045\text{ V}$		229	
		$V_{CCB} = 1.2\text{ V} \pm 0.1\text{ V}$		97	
		$V_{CCB} = 1.5\text{ V} \pm 0.1\text{ V}$		80	
		$V_{CCB} = 1.8\text{ V} \pm 0.15\text{ V}$		78	
		$V_{CCB} = 2.5\text{ V} \pm 0.2\text{ V}$		76	
		$V_{CCB} = 3.3\text{ V} \pm 0.3\text{ V}$		87	
	Port B	$V_{CCB} = 0.7\text{ V} \pm 0.05\text{ V}$		317	ns
		$V_{CCB} = 0.8\text{ V} \pm 0.04\text{ V}$		259	
		$V_{CCB} = 0.9\text{ V} \pm 0.045\text{ V}$		228	
		$V_{CCB} = 1.2\text{ V} \pm 0.1\text{ V}$		197	
		$V_{CCB} = 1.5\text{ V} \pm 0.1\text{ V}$		191	
		$V_{CCB} = 1.8\text{ V} \pm 0.15\text{ V}$		190	
		$V_{CCB} = 2.5\text{ V} \pm 0.2\text{ V}$		191	
	$V_{CCB} = 3.3\text{ V} \pm 0.3\text{ V}$		200		

6.11 Switching Characteristics: $V_{CCA} = 0.9\text{ V}$, $T_A = -40^\circ\text{C}$ to $+85^\circ\text{C}$

 over recommended operating free-air temperature range, $V_{CCA} = 0.9\text{ V}$ (see [Figure 3](#))

PARAMETER	TEST CONDITIONS		MIN	MAX	UNIT
t_{pd} Propagation delay	A-to-B	$V_{CCB} = 0.7\text{ V} \pm 0.05\text{ V}$	0.5	126	ns
		$V_{CCB} = 0.8\text{ V} \pm 0.04\text{ V}$	0.5	78	
		$V_{CCB} = 0.9\text{ V} \pm 0.045\text{ V}$	0.5	52	
		$V_{CCB} = 1.2\text{ V} \pm 0.1\text{ V}$	0.5	23	
		$V_{CCB} = 1.5\text{ V} \pm 0.1\text{ V}$	0.5	18	
		$V_{CCB} = 1.8\text{ V} \pm 0.15\text{ V}$	0.5	16	
		$V_{CCB} = 2.5\text{ V} \pm 0.2\text{ V}$	0.5	15	
		$V_{CCB} = 3.3\text{ V} \pm 0.3\text{ V}$	0.5	18	
	B-to-A	$V_{CCB} = 0.7\text{ V} \pm 0.05\text{ V}$	0.5	85	ns
		$V_{CCB} = 0.8\text{ V} \pm 0.04\text{ V}$	0.5	64	
		$V_{CCB} = 0.9\text{ V} \pm 0.045\text{ V}$	0.5	53	
		$V_{CCB} = 1.2\text{ V} \pm 0.1\text{ V}$	0.5	40	
		$V_{CCB} = 1.5\text{ V} \pm 0.1\text{ V}$	0.5	28	
		$V_{CCB} = 1.8\text{ V} \pm 0.15\text{ V}$	0.5	24	
$V_{CCB} = 2.5\text{ V} \pm 0.2\text{ V}$		0.5	22		
$V_{CCB} = 3.3\text{ V} \pm 0.3\text{ V}$		0.5	21		
t_{dis} Disable time	Port A	$V_{CCB} = 0.7\text{ V} \pm 0.05\text{ V}$	0.5	75	ns
		$V_{CCB} = 0.8\text{ V} \pm 0.04\text{ V}$	0.5	75	
		$V_{CCB} = 0.9\text{ V} \pm 0.045\text{ V}$	0.5	75	
		$V_{CCB} = 1.2\text{ V} \pm 0.1\text{ V}$	0.5	75	
		$V_{CCB} = 1.5\text{ V} \pm 0.1\text{ V}$	0.5	75	
		$V_{CCB} = 1.8\text{ V} \pm 0.15\text{ V}$	0.5	75	
		$V_{CCB} = 2.5\text{ V} \pm 0.2\text{ V}$	0.5	75	
		$V_{CCB} = 3.3\text{ V} \pm 0.3\text{ V}$	0.5	75	
	Port B	$V_{CCB} = 0.7\text{ V} \pm 0.05\text{ V}$	0.5	144	ns
		$V_{CCB} = 0.8\text{ V} \pm 0.04\text{ V}$	0.5	105	
		$V_{CCB} = 0.9\text{ V} \pm 0.045\text{ V}$	0.5	82	
		$V_{CCB} = 1.2\text{ V} \pm 0.1\text{ V}$	0.5	32	
		$V_{CCB} = 1.5\text{ V} \pm 0.1\text{ V}$	0.5	25	
		$V_{CCB} = 1.8\text{ V} \pm 0.15\text{ V}$	0.5	24	
$V_{CCB} = 2.5\text{ V} \pm 0.2\text{ V}$		0.5	21		
$V_{CCB} = 3.3\text{ V} \pm 0.3\text{ V}$		0.5	23		

Switching Characteristics: $V_{CCA} = 0.9\text{ V}$, $T_A = -40^\circ\text{C}$ to $+85^\circ\text{C}$ (continued)

 over recommended operating free-air temperature range, $V_{CCA} = 0.9\text{ V}$ (see [Figure 3](#))

PARAMETER	TEST CONDITIONS	MIN	MAX	UNIT	
t_{en} Enable time	Port A	$V_{CCB} = 0.7\text{ V} \pm 0.05\text{ V}$		282	ns
		$V_{CCB} = 0.8\text{ V} \pm 0.04\text{ V}$		223	
		$V_{CCB} = 0.9\text{ V} \pm 0.045\text{ V}$		195	
		$V_{CCB} = 1.2\text{ V} \pm 0.1\text{ V}$		77	
		$V_{CCB} = 1.5\text{ V} \pm 0.1\text{ V}$		59	
		$V_{CCB} = 1.8\text{ V} \pm 0.15\text{ V}$		54	
		$V_{CCB} = 2.5\text{ V} \pm 0.2\text{ V}$		48	
		$V_{CCB} = 3.3\text{ V} \pm 0.3\text{ V}$		54	
	Port B	$V_{CCB} = 0.7\text{ V} \pm 0.05\text{ V}$		262	ns
		$V_{CCB} = 0.8\text{ V} \pm 0.04\text{ V}$		214	
		$V_{CCB} = 0.9\text{ V} \pm 0.045\text{ V}$		188	
		$V_{CCB} = 1.2\text{ V} \pm 0.1\text{ V}$		159	
		$V_{CCB} = 1.5\text{ V} \pm 0.1\text{ V}$		154	
		$V_{CCB} = 1.8\text{ V} \pm 0.15\text{ V}$		152	
		$V_{CCB} = 2.5\text{ V} \pm 0.2\text{ V}$		151	
		$V_{CCB} = 3.3\text{ V} \pm 0.3\text{ V}$		154	

6.12 Switching Characteristics: $V_{CCA} = 0.9\text{ V}$, $T_A = -40^\circ\text{C}$ to $+125^\circ\text{C}$

 over recommended operating free-air temperature range, $V_{CCA} = 0.9\text{ V}$ (see [Figure 11](#))

PARAMETER	TEST CONDITIONS		MIN	MAX	UNIT
t_{pd} Propagation delay	A-to-B	$V_{CCB} = 0.7\text{ V} \pm 0.05\text{ V}$	0.5	126	ns
		$V_{CCB} = 0.8\text{ V} \pm 0.04\text{ V}$	0.5	78	
		$V_{CCB} = 0.9\text{ V} \pm 0.045\text{ V}$	0.5	52	
		$V_{CCB} = 1.2\text{ V} \pm 0.1\text{ V}$	0.5	23	
		$V_{CCB} = 1.5\text{ V} \pm 0.1\text{ V}$	0.5	18	
		$V_{CCB} = 1.8\text{ V} \pm 0.15\text{ V}$	0.5	16	
		$V_{CCB} = 2.5\text{ V} \pm 0.2\text{ V}$	0.5	15	
		$V_{CCB} = 3.3\text{ V} \pm 0.3\text{ V}$	0.5	18	
	B-to-A	$V_{CCB} = 0.7\text{ V} \pm 0.05\text{ V}$	0.5	85	ns
		$V_{CCB} = 0.8\text{ V} \pm 0.04\text{ V}$	0.5	64	
		$V_{CCB} = 0.9\text{ V} \pm 0.045\text{ V}$	0.5	53	
		$V_{CCB} = 1.2\text{ V} \pm 0.1\text{ V}$	0.5	40	
		$V_{CCB} = 1.5\text{ V} \pm 0.1\text{ V}$	0.5	28	
		$V_{CCB} = 1.8\text{ V} \pm 0.15\text{ V}$	0.5	24	
$V_{CCB} = 2.5\text{ V} \pm 0.2\text{ V}$		0.5	22		
$V_{CCB} = 3.3\text{ V} \pm 0.3\text{ V}$		0.5	21		
t_{dis} Disable time	Port A	$V_{CCB} = 0.7\text{ V} \pm 0.05\text{ V}$	0.5	79	ns
		$V_{CCB} = 0.8\text{ V} \pm 0.04\text{ V}$	0.5	79	
		$V_{CCB} = 0.9\text{ V} \pm 0.045\text{ V}$	0.5	79	
		$V_{CCB} = 1.2\text{ V} \pm 0.1\text{ V}$	0.5	79	
		$V_{CCB} = 1.5\text{ V} \pm 0.1\text{ V}$	0.5	79	
		$V_{CCB} = 1.8\text{ V} \pm 0.15\text{ V}$	0.5	79	
		$V_{CCB} = 2.5\text{ V} \pm 0.2\text{ V}$	0.5	79	
		$V_{CCB} = 3.3\text{ V} \pm 0.3\text{ V}$	0.5	79	
	Port B	$V_{CCB} = 0.7\text{ V} \pm 0.05\text{ V}$	0.5	144	ns
		$V_{CCB} = 0.8\text{ V} \pm 0.04\text{ V}$	0.5	105	
		$V_{CCB} = 0.9\text{ V} \pm 0.045\text{ V}$	0.5	83	
		$V_{CCB} = 1.2\text{ V} \pm 0.1\text{ V}$	0.5	36	
		$V_{CCB} = 1.5\text{ V} \pm 0.1\text{ V}$	0.5	28	
		$V_{CCB} = 1.8\text{ V} \pm 0.15\text{ V}$	0.5	26	
$V_{CCB} = 2.5\text{ V} \pm 0.2\text{ V}$		0.5	21		
$V_{CCB} = 3.3\text{ V} \pm 0.3\text{ V}$		0.5	23		

Switching Characteristics: $V_{CCA} = 0.9\text{ V}$, $T_A = -40^\circ\text{C}$ to $+125^\circ\text{C}$ (continued)

 over recommended operating free-air temperature range, $V_{CCA} = 0.9\text{ V}$ (see [Figure 11](#))

PARAMETER	TEST CONDITIONS	MIN	MAX	UNIT	
t_{en} Enable time	Port A	$V_{CCB} = 0.7\text{ V} \pm 0.05\text{ V}$		304	ns
		$V_{CCB} = 0.8\text{ V} \pm 0.04\text{ V}$		229	
		$V_{CCB} = 0.9\text{ V} \pm 0.045\text{ V}$		199	
		$V_{CCB} = 1.2\text{ V} \pm 0.1\text{ V}$		81	
		$V_{CCB} = 1.5\text{ V} \pm 0.1\text{ V}$		62	
		$V_{CCB} = 1.8\text{ V} \pm 0.15\text{ V}$		56	
		$V_{CCB} = 2.5\text{ V} \pm 0.2\text{ V}$		49	
		$V_{CCB} = 3.3\text{ V} \pm 0.3\text{ V}$		54	
	Port B	$V_{CCB} = 0.7\text{ V} \pm 0.05\text{ V}$		269	ns
		$V_{CCB} = 0.8\text{ V} \pm 0.04\text{ V}$		221	
		$V_{CCB} = 0.9\text{ V} \pm 0.045\text{ V}$		195	
		$V_{CCB} = 1.2\text{ V} \pm 0.1\text{ V}$		166	
		$V_{CCB} = 1.5\text{ V} \pm 0.1\text{ V}$		161	
		$V_{CCB} = 1.8\text{ V} \pm 0.15\text{ V}$		159	
		$V_{CCB} = 2.5\text{ V} \pm 0.2\text{ V}$		158	
$V_{CCB} = 3.3\text{ V} \pm 0.3\text{ V}$		161			

6.13 Switching Characteristics: $V_{CCA} = 1.2\text{ V}$, $T_A = -40^\circ\text{C}$ to $+85^\circ\text{C}$

 over recommended operating free-air temperature range, $V_{CCA} = 1.2\text{ V}$ (see [Figure 4](#))

PARAMETER	TEST CONDITIONS		MIN	MAX	UNIT
t_{pd} Propagation delay	A-to-B	$V_{CCB} = 0.7\text{ V} \pm 0.05\text{ V}$	0.5	87	ns
		$V_{CCB} = 0.8\text{ V} \pm 0.04\text{ V}$	0.5	52	
		$V_{CCB} = 0.9\text{ V} \pm 0.045\text{ V}$	0.5	39	
		$V_{CCB} = 1.2\text{ V} \pm 0.1\text{ V}$	0.5	15	
		$V_{CCB} = 1.5\text{ V} \pm 0.1\text{ V}$	0.5	9	
		$V_{CCB} = 1.8\text{ V} \pm 0.15\text{ V}$	0.5	8	
		$V_{CCB} = 2.5\text{ V} \pm 0.2\text{ V}$	0.5	7	
		$V_{CCB} = 3.3\text{ V} \pm 0.3\text{ V}$	0.5	7	
	B-to-A	$V_{CCB} = 0.7\text{ V} \pm 0.05\text{ V}$	0.5	51	ns
		$V_{CCB} = 0.8\text{ V} \pm 0.04\text{ V}$	0.5	33	
		$V_{CCB} = 0.9\text{ V} \pm 0.045\text{ V}$	0.5	23	
		$V_{CCB} = 1.2\text{ V} \pm 0.1\text{ V}$	0.5	15	
		$V_{CCB} = 1.5\text{ V} \pm 0.1\text{ V}$	0.5	12	
		$V_{CCB} = 1.8\text{ V} \pm 0.15\text{ V}$	0.5	10	
$V_{CCB} = 2.5\text{ V} \pm 0.2\text{ V}$		0.5	7		
$V_{CCB} = 3.3\text{ V} \pm 0.3\text{ V}$		0.5	7		
t_{dis} Disable time	Port A	$V_{CCB} = 0.7\text{ V} \pm 0.05\text{ V}$	0.5	22	ns
		$V_{CCB} = 0.8\text{ V} \pm 0.04\text{ V}$	0.5	22	
		$V_{CCB} = 0.9\text{ V} \pm 0.045\text{ V}$	0.5	22	
		$V_{CCB} = 1.2\text{ V} \pm 0.1\text{ V}$	0.5	22	
		$V_{CCB} = 1.5\text{ V} \pm 0.1\text{ V}$	0.5	22	
		$V_{CCB} = 1.8\text{ V} \pm 0.15\text{ V}$	0.5	22	
		$V_{CCB} = 2.5\text{ V} \pm 0.2\text{ V}$	0.5	22	
		$V_{CCB} = 3.3\text{ V} \pm 0.3\text{ V}$	0.5	22	
	Port B	$V_{CCB} = 0.7\text{ V} \pm 0.05\text{ V}$	0.5	137	ns
		$V_{CCB} = 0.8\text{ V} \pm 0.04\text{ V}$	0.5	98	
		$V_{CCB} = 0.9\text{ V} \pm 0.045\text{ V}$	0.5	74	
		$V_{CCB} = 1.2\text{ V} \pm 0.1\text{ V}$	0.5	24	
		$V_{CCB} = 1.5\text{ V} \pm 0.1\text{ V}$	0.5	18	
		$V_{CCB} = 1.8\text{ V} \pm 0.15\text{ V}$	0.5	16	
$V_{CCB} = 2.5\text{ V} \pm 0.2\text{ V}$		0.5	13		
$V_{CCB} = 3.3\text{ V} \pm 0.3\text{ V}$		0.5	13		

Switching Characteristics: $V_{CCA} = 1.2\text{ V}$, $T_A = -40^\circ\text{C}$ to $+85^\circ\text{C}$ (continued)

 over recommended operating free-air temperature range, $V_{CCA} = 1.2\text{ V}$ (see [Figure 4](#))

PARAMETER		TEST CONDITIONS	MIN	MAX	UNIT	
t_{en}	Enable time	Port A	$V_{CCB} = 0.7\text{ V} \pm 0.05\text{ V}$		240	ns
			$V_{CCB} = 0.8\text{ V} \pm 0.04\text{ V}$		185	
			$V_{CCB} = 0.9\text{ V} \pm 0.045\text{ V}$		157	
			$V_{CCB} = 1.2\text{ V} \pm 0.1\text{ V}$		45	
			$V_{CCB} = 1.5\text{ V} \pm 0.1\text{ V}$		36	
			$V_{CCB} = 1.8\text{ V} \pm 0.15\text{ V}$		33	
			$V_{CCB} = 2.5\text{ V} \pm 0.2\text{ V}$		26	
			$V_{CCB} = 3.3\text{ V} \pm 0.3\text{ V}$		29	
	Port B	$V_{CCB} = 0.7\text{ V} \pm 0.05\text{ V}$		115	ns	
		$V_{CCB} = 0.8\text{ V} \pm 0.04\text{ V}$		80		
		$V_{CCB} = 0.9\text{ V} \pm 0.045\text{ V}$		67		
		$V_{CCB} = 1.2\text{ V} \pm 0.1\text{ V}$		43		
		$V_{CCB} = 1.5\text{ V} \pm 0.1\text{ V}$		37		
		$V_{CCB} = 1.8\text{ V} \pm 0.15\text{ V}$		36		
		$V_{CCB} = 2.5\text{ V} \pm 0.2\text{ V}$		35		
		$V_{CCB} = 3.3\text{ V} \pm 0.3\text{ V}$		35		

6.14 Switching Characteristics: $V_{CCA} = 1.2\text{ V}$, $T_A = -40^\circ\text{C}$ to $+125^\circ\text{C}$

 over recommended operating free-air temperature range, $V_{CCA} = 1.2\text{ V}$ (see [Figure 12](#))

PARAMETER	TEST CONDITIONS		MIN	MAX	UNIT
t_{pd} Propagation delay	A-to-B	$V_{CCB} = 0.7\text{ V} \pm 0.05\text{ V}$	0.5	87	ns
		$V_{CCB} = 0.8\text{ V} \pm 0.04\text{ V}$	0.5	52	
		$V_{CCB} = 0.9\text{ V} \pm 0.045\text{ V}$	0.5	39	
		$V_{CCB} = 1.2\text{ V} \pm 0.1\text{ V}$	0.5	15	
		$V_{CCB} = 1.5\text{ V} \pm 0.1\text{ V}$	0.5	10	
		$V_{CCB} = 1.8\text{ V} \pm 0.15\text{ V}$	0.5	9	
		$V_{CCB} = 2.5\text{ V} \pm 0.2\text{ V}$	0.5	7	
		$V_{CCB} = 3.3\text{ V} \pm 0.3\text{ V}$	0.5	8	
	B-to-A	$V_{CCB} = 0.7\text{ V} \pm 0.05\text{ V}$	0.5	51	ns
		$V_{CCB} = 0.8\text{ V} \pm 0.04\text{ V}$	0.5	33	
		$V_{CCB} = 0.9\text{ V} \pm 0.045\text{ V}$	0.5	23	
		$V_{CCB} = 1.2\text{ V} \pm 0.1\text{ V}$	0.5	15	
		$V_{CCB} = 1.5\text{ V} \pm 0.1\text{ V}$	0.5	12	
		$V_{CCB} = 1.8\text{ V} \pm 0.15\text{ V}$	0.5	10	
$V_{CCB} = 2.5\text{ V} \pm 0.2\text{ V}$		0.5	8		
$V_{CCB} = 3.3\text{ V} \pm 0.3\text{ V}$		0.5	7		
t_{dis} Disable time	Port A	$V_{CCB} = 0.7\text{ V} \pm 0.05\text{ V}$	0.5	29	ns
		$V_{CCB} = 0.8\text{ V} \pm 0.04\text{ V}$	0.5	29	
		$V_{CCB} = 0.9\text{ V} \pm 0.045\text{ V}$	0.5	29	
		$V_{CCB} = 1.2\text{ V} \pm 0.1\text{ V}$	0.5	29	
		$V_{CCB} = 1.5\text{ V} \pm 0.1\text{ V}$	0.5	29	
		$V_{CCB} = 1.8\text{ V} \pm 0.15\text{ V}$	0.5	29	
		$V_{CCB} = 2.5\text{ V} \pm 0.2\text{ V}$	0.5	29	
		$V_{CCB} = 3.3\text{ V} \pm 0.3\text{ V}$	0.5	29	
	Port B	$V_{CCB} = 0.7\text{ V} \pm 0.05\text{ V}$	0.5	137	ns
		$V_{CCB} = 0.8\text{ V} \pm 0.04\text{ V}$	0.5	98	
		$V_{CCB} = 0.9\text{ V} \pm 0.045\text{ V}$	0.5	78	
		$V_{CCB} = 1.2\text{ V} \pm 0.1\text{ V}$	0.5	30	
		$V_{CCB} = 1.5\text{ V} \pm 0.1\text{ V}$	0.5	23	
		$V_{CCB} = 1.8\text{ V} \pm 0.15\text{ V}$	0.5	21	
$V_{CCB} = 2.5\text{ V} \pm 0.2\text{ V}$		0.5	17		
$V_{CCB} = 3.3\text{ V} \pm 0.3\text{ V}$		0.5	16		

Switching Characteristics: $V_{CCA} = 1.2\text{ V}$, $T_A = -40^\circ\text{C}$ to $+125^\circ\text{C}$ (continued)

 over recommended operating free-air temperature range, $V_{CCA} = 1.2\text{ V}$ (see [Figure 12](#))

PARAMETER	TEST CONDITIONS		MIN	MAX	UNIT
t_{en} Enable time	Port A	$V_{CCB} = 0.7\text{ V} \pm 0.05\text{ V}$		265	ns
		$V_{CCB} = 0.8\text{ V} \pm 0.04\text{ V}$		193	
		$V_{CCB} = 0.9\text{ V} \pm 0.045\text{ V}$		164	
		$V_{CCB} = 1.2\text{ V} \pm 0.1\text{ V}$		51	
		$V_{CCB} = 1.5\text{ V} \pm 0.1\text{ V}$		41	
		$V_{CCB} = 1.8\text{ V} \pm 0.15\text{ V}$		37	
		$V_{CCB} = 2.5\text{ V} \pm 0.2\text{ V}$		30	
		$V_{CCB} = 3.3\text{ V} \pm 0.3\text{ V}$		32	
	Port B	$V_{CCB} = 0.7\text{ V} \pm 0.05\text{ V}$		121	ns
		$V_{CCB} = 0.8\text{ V} \pm 0.04\text{ V}$		86	
		$V_{CCB} = 0.9\text{ V} \pm 0.045\text{ V}$		73	
		$V_{CCB} = 1.2\text{ V} \pm 0.1\text{ V}$		49	
		$V_{CCB} = 1.5\text{ V} \pm 0.1\text{ V}$		44	
		$V_{CCB} = 1.8\text{ V} \pm 0.15\text{ V}$		43	
		$V_{CCB} = 2.5\text{ V} \pm 0.2\text{ V}$		41	
$V_{CCB} = 3.3\text{ V} \pm 0.3\text{ V}$		42			

6.15 Switching Characteristics: $V_{CCA} = 1.5\text{ V}$, $T_A = -40^\circ\text{C}$ to $+85^\circ\text{C}$

 over recommended operating free-air temperature range, $V_{CCB} = 1.5\text{ V}$ (see [Figure 5](#))

PARAMETER	TEST CONDITIONS		MIN	MAX	UNIT
t_{pd} Propagation delay	A-to-B	$V_{CCB} = 0.7\text{ V} \pm 0.05\text{ V}$	0.5	83	ns
		$V_{CCB} = 0.8\text{ V} \pm 0.04\text{ V}$	0.5	42	
		$V_{CCB} = 0.9\text{ V} \pm 0.045\text{ V}$	0.5	28	
		$V_{CCB} = 1.2\text{ V} \pm 0.1\text{ V}$	0.5	12	
		$V_{CCB} = 1.5\text{ V} \pm 0.1\text{ V}$	0.5	8	
		$V_{CCB} = 1.8\text{ V} \pm 0.15\text{ V}$	0.5	7	
		$V_{CCB} = 2.5\text{ V} \pm 0.2\text{ V}$	0.5	5	
		$V_{CCB} = 3.3\text{ V} \pm 0.3\text{ V}$	0.5	5	
	B-to-A	$V_{CCB} = 0.7\text{ V} \pm 0.05\text{ V}$	0.5	50	
		$V_{CCB} = 0.8\text{ V} \pm 0.04\text{ V}$	0.5	28	
		$V_{CCB} = 0.9\text{ V} \pm 0.045\text{ V}$	0.5	18	
		$V_{CCB} = 1.2\text{ V} \pm 0.1\text{ V}$	0.5	10	
		$V_{CCB} = 1.5\text{ V} \pm 0.1\text{ V}$	0.5	8	
		$V_{CCB} = 1.8\text{ V} \pm 0.15\text{ V}$	0.5	7	
$V_{CCB} = 2.5\text{ V} \pm 0.2\text{ V}$		0.5	5		
$V_{CCB} = 3.3\text{ V} \pm 0.3\text{ V}$		0.5	4		
t_{dis} Disable time	Port A	$V_{CCB} = 0.7\text{ V} \pm 0.05\text{ V}$	0.5	15	ns
		$V_{CCB} = 0.8\text{ V} \pm 0.04\text{ V}$	0.5	15	
		$V_{CCB} = 0.9\text{ V} \pm 0.045\text{ V}$	0.5	15	
		$V_{CCB} = 1.2\text{ V} \pm 0.1\text{ V}$	0.5	15	
		$V_{CCB} = 1.5\text{ V} \pm 0.1\text{ V}$	0.5	15	
		$V_{CCB} = 1.8\text{ V} \pm 0.15\text{ V}$	0.5	15	
		$V_{CCB} = 2.5\text{ V} \pm 0.2\text{ V}$	0.5	15	
		$V_{CCB} = 3.3\text{ V} \pm 0.3\text{ V}$	0.5	15	
	Port B	$V_{CCB} = 0.7\text{ V} \pm 0.05\text{ V}$	0.5	136	
		$V_{CCB} = 0.8\text{ V} \pm 0.04\text{ V}$	0.5	96	
		$V_{CCB} = 0.9\text{ V} \pm 0.045\text{ V}$	0.5	72	
		$V_{CCB} = 1.2\text{ V} \pm 0.1\text{ V}$	0.5	22	
		$V_{CCB} = 1.5\text{ V} \pm 0.1\text{ V}$	0.5	16	
		$V_{CCB} = 1.8\text{ V} \pm 0.15\text{ V}$	0.5	14	
$V_{CCB} = 2.5\text{ V} \pm 0.2\text{ V}$		0.5	11		
$V_{CCB} = 3.3\text{ V} \pm 0.3\text{ V}$		0.5	11		

Switching Characteristics: $V_{CCA} = 1.5\text{ V}$, $T_A = -40^\circ\text{C}$ to $+85^\circ\text{C}$ (continued)

 over recommended operating free-air temperature range, $V_{CCA} = 1.5\text{ V}$ (see [Figure 5](#))

PARAMETER	TEST CONDITIONS	MIN	MAX	UNIT	
t_{en} Enable time	Port A	$V_{CCB} = 0.7\text{ V} \pm 0.05\text{ V}$		238	ns
		$V_{CCB} = 0.8\text{ V} \pm 0.04\text{ V}$		178	
		$V_{CCB} = 0.9\text{ V} \pm 0.045\text{ V}$		151	
		$V_{CCB} = 1.2\text{ V} \pm 0.1\text{ V}$		38	
		$V_{CCB} = 1.5\text{ V} \pm 0.1\text{ V}$		30	
		$V_{CCB} = 1.8\text{ V} \pm 0.15\text{ V}$		28	
		$V_{CCB} = 2.5\text{ V} \pm 0.2\text{ V}$		22	
		$V_{CCB} = 3.3\text{ V} \pm 0.3\text{ V}$		24	
	Port B	$V_{CCB} = 0.7\text{ V} \pm 0.05\text{ V}$		104	
		$V_{CCB} = 0.8\text{ V} \pm 0.04\text{ V}$		63	
		$V_{CCB} = 0.9\text{ V} \pm 0.045\text{ V}$		49	
		$V_{CCB} = 1.2\text{ V} \pm 0.1\text{ V}$		33	
		$V_{CCB} = 1.5\text{ V} \pm 0.1\text{ V}$		29	
		$V_{CCB} = 1.8\text{ V} \pm 0.15\text{ V}$		28	
		$V_{CCB} = 2.5\text{ V} \pm 0.2\text{ V}$		26	
		$V_{CCB} = 3.3\text{ V} \pm 0.3\text{ V}$		26	

6.16 Switching Characteristics: $V_{CCA} = 1.5\text{ V}$, $T_A = -40^\circ\text{C}$ to $+125^\circ\text{C}$

 over recommended operating free-air temperature range, $V_{CCA} = 1.5\text{ V}$ (see [Figure 13](#))

PARAMETER		TEST CONDITIONS	MIN	MAX	UNIT	
t_{pd}	Propagation delay	A-to-B	$V_{CCB} = 0.7\text{ V} \pm 0.05\text{ V}$	0.5	83	ns
			$V_{CCB} = 0.8\text{ V} \pm 0.04\text{ V}$	0.5	42	
			$V_{CCB} = 0.9\text{ V} \pm 0.045\text{ V}$	0.5	28	
			$V_{CCB} = 1.2\text{ V} \pm 0.1\text{ V}$	0.5	12	
			$V_{CCB} = 1.5\text{ V} \pm 0.1\text{ V}$	0.5	9	
			$V_{CCB} = 1.8\text{ V} \pm 0.15\text{ V}$	0.5	8	
			$V_{CCB} = 2.5\text{ V} \pm 0.2\text{ V}$	0.5	6	
			$V_{CCB} = 3.3\text{ V} \pm 0.3\text{ V}$	0.5	6	
		B-to-A	$V_{CCB} = 0.7\text{ V} \pm 0.05\text{ V}$	0.5	50	
			$V_{CCB} = 0.8\text{ V} \pm 0.04\text{ V}$	0.5	28	
			$V_{CCB} = 0.9\text{ V} \pm 0.045\text{ V}$	0.5	18	
			$V_{CCB} = 1.2\text{ V} \pm 0.1\text{ V}$	0.5	10	
			$V_{CCB} = 1.5\text{ V} \pm 0.1\text{ V}$	0.5	9	
			$V_{CCB} = 1.8\text{ V} \pm 0.15\text{ V}$	0.5	8	
			$V_{CCB} = 2.5\text{ V} \pm 0.2\text{ V}$	0.5	6	
			$V_{CCB} = 3.3\text{ V} \pm 0.3\text{ V}$	0.5	5	
t_{dis}	Disable time	Port A	$V_{CCB} = 0.7\text{ V} \pm 0.05\text{ V}$	0.5	20	ns
			$V_{CCB} = 0.8\text{ V} \pm 0.04\text{ V}$	0.5	20	
			$V_{CCB} = 0.9\text{ V} \pm 0.045\text{ V}$	0.5	20	
			$V_{CCB} = 1.2\text{ V} \pm 0.1\text{ V}$	0.5	20	
			$V_{CCB} = 1.5\text{ V} \pm 0.1\text{ V}$	0.5	20	
			$V_{CCB} = 1.8\text{ V} \pm 0.15\text{ V}$	0.5	20	
			$V_{CCB} = 2.5\text{ V} \pm 0.2\text{ V}$	0.5	20	
			$V_{CCB} = 3.3\text{ V} \pm 0.3\text{ V}$	0.5	20	
		Port B	$V_{CCB} = 0.7\text{ V} \pm 0.05\text{ V}$	0.5	136	
			$V_{CCB} = 0.8\text{ V} \pm 0.04\text{ V}$	0.5	96	
			$V_{CCB} = 0.9\text{ V} \pm 0.045\text{ V}$	0.5	76	
			$V_{CCB} = 1.2\text{ V} \pm 0.1\text{ V}$	0.5	29	
			$V_{CCB} = 1.5\text{ V} \pm 0.1\text{ V}$	0.5	21	
			$V_{CCB} = 1.8\text{ V} \pm 0.15\text{ V}$	0.5	19	
			$V_{CCB} = 2.5\text{ V} \pm 0.2\text{ V}$	0.5	15	
			$V_{CCB} = 3.3\text{ V} \pm 0.3\text{ V}$	0.5	14	

Switching Characteristics: $V_{CCA} = 1.5\text{ V}$, $T_A = -40^\circ\text{C}$ to $+125^\circ\text{C}$ (continued)

 over recommended operating free-air temperature range, $V_{CCA} = 1.5\text{ V}$ (see [Figure 13](#))

PARAMETER	TEST CONDITIONS	MIN	MAX	UNIT	
t_{en} Enable time	Port A	$V_{CCB} = 0.7\text{ V} \pm 0.05\text{ V}$		263	ns
		$V_{CCB} = 0.8\text{ V} \pm 0.04\text{ V}$		186	
		$V_{CCB} = 0.9\text{ V} \pm 0.045\text{ V}$		157	
		$V_{CCB} = 1.2\text{ V} \pm 0.1\text{ V}$		44	
		$V_{CCB} = 1.5\text{ V} \pm 0.1\text{ V}$		36	
		$V_{CCB} = 1.8\text{ V} \pm 0.15\text{ V}$		33	
		$V_{CCB} = 2.5\text{ V} \pm 0.2\text{ V}$		26	
		$V_{CCB} = 3.3\text{ V} \pm 0.3\text{ V}$		27	
	Port B	$V_{CCB} = 0.7\text{ V} \pm 0.05\text{ V}$		109	
		$V_{CCB} = 0.8\text{ V} \pm 0.04\text{ V}$		68	
		$V_{CCB} = 0.9\text{ V} \pm 0.045\text{ V}$		54	
		$V_{CCB} = 1.2\text{ V} \pm 0.1\text{ V}$		38	
		$V_{CCB} = 1.5\text{ V} \pm 0.1\text{ V}$		35	
		$V_{CCB} = 1.8\text{ V} \pm 0.15\text{ V}$		34	
		$V_{CCB} = 2.5\text{ V} \pm 0.2\text{ V}$		32	
		$V_{CCB} = 3.3\text{ V} \pm 0.3\text{ V}$		32	

6.17 Switching Characteristics: $V_{CCA} = 1.8\text{ V}$, $T_A = -40^\circ\text{C}$ to $+85^\circ\text{C}$

 over recommended operating free-air temperature range, $V_{CCA} = 1.8\text{ V}$ (see [Figure 6](#))

PARAMETER	TEST CONDITIONS		MIN	MAX	UNIT
t_{pd} Propagation delay	A-to-B	$V_{CCB} = 0.7\text{ V} \pm 0.05\text{ V}$	0.5	81	ns
		$V_{CCB} = 0.8\text{ V} \pm 0.04\text{ V}$	0.5	41	
		$V_{CCB} = 0.9\text{ V} \pm 0.045\text{ V}$	0.5	24	
		$V_{CCB} = 1.2\text{ V} \pm 0.1\text{ V}$	0.5	10	
		$V_{CCB} = 1.5\text{ V} \pm 0.1\text{ V}$	0.5	7	
		$V_{CCB} = 1.8\text{ V} \pm 0.15\text{ V}$	0.5	6	
		$V_{CCB} = 2.5\text{ V} \pm 0.2\text{ V}$	0.5	5	
		$V_{CCB} = 3.3\text{ V} \pm 0.3\text{ V}$	0.5	4	
	B-to-A	$V_{CCB} = 0.7\text{ V} \pm 0.05\text{ V}$	0.5	53	
		$V_{CCB} = 0.8\text{ V} \pm 0.04\text{ V}$	0.5	26	
		$V_{CCB} = 0.9\text{ V} \pm 0.045\text{ V}$	0.5	16	
		$V_{CCB} = 1.2\text{ V} \pm 0.1\text{ V}$	0.5	8	
		$V_{CCB} = 1.5\text{ V} \pm 0.1\text{ V}$	0.5	7	
		$V_{CCB} = 1.8\text{ V} \pm 0.15\text{ V}$	0.5	6	
$V_{CCB} = 2.5\text{ V} \pm 0.2\text{ V}$		0.5	5		
	$V_{CCB} = 3.3\text{ V} \pm 0.3\text{ V}$	0.5	4		
t_{dis} Disable time	Port A	$V_{CCB} = 0.7\text{ V} \pm 0.05\text{ V}$	0.5	13	ns
		$V_{CCB} = 0.8\text{ V} \pm 0.04\text{ V}$	0.5	13	
		$V_{CCB} = 0.9\text{ V} \pm 0.045\text{ V}$	0.5	13	
		$V_{CCB} = 1.2\text{ V} \pm 0.1\text{ V}$	0.5	13	
		$V_{CCB} = 1.5\text{ V} \pm 0.1\text{ V}$	0.5	13	
		$V_{CCB} = 1.8\text{ V} \pm 0.15\text{ V}$	0.5	13	
		$V_{CCB} = 2.5\text{ V} \pm 0.2\text{ V}$	0.5	13	
		$V_{CCB} = 3.3\text{ V} \pm 0.3\text{ V}$	0.5	13	
	Port B	$V_{CCB} = 0.7\text{ V} \pm 0.05\text{ V}$	0.5	136	
		$V_{CCB} = 0.8\text{ V} \pm 0.04\text{ V}$	0.5	96	
		$V_{CCB} = 0.9\text{ V} \pm 0.045\text{ V}$	0.5	72	
		$V_{CCB} = 1.2\text{ V} \pm 0.1\text{ V}$	0.5	22	
		$V_{CCB} = 1.5\text{ V} \pm 0.1\text{ V}$	0.5	15	
		$V_{CCB} = 1.8\text{ V} \pm 0.15\text{ V}$	0.5	14	
$V_{CCB} = 2.5\text{ V} \pm 0.2\text{ V}$		0.5	11		
	$V_{CCB} = 3.3\text{ V} \pm 0.3\text{ V}$	0.5	11		

Switching Characteristics: $V_{CCA} = 1.8\text{ V}$, $T_A = -40^\circ\text{C}$ to $+85^\circ\text{C}$ (continued)

 over recommended operating free-air temperature range, $V_{CCA} = 1.8\text{ V}$ (see [Figure 6](#))

PARAMETER	TEST CONDITIONS		MIN	MAX	UNIT
t_{en} Enable time	Port A	$V_{CCB} = 0.7\text{ V} \pm 0.05\text{ V}$		241	ns
		$V_{CCB} = 0.8\text{ V} \pm 0.04\text{ V}$		176	
		$V_{CCB} = 0.9\text{ V} \pm 0.045\text{ V}$		148	
		$V_{CCB} = 1.2\text{ V} \pm 0.1\text{ V}$		35	
		$V_{CCB} = 1.5\text{ V} \pm 0.1\text{ V}$		28	
		$V_{CCB} = 1.8\text{ V} \pm 0.15\text{ V}$		26	
		$V_{CCB} = 2.5\text{ V} \pm 0.2\text{ V}$		21	
		$V_{CCB} = 3.3\text{ V} \pm 0.3\text{ V}$		24	
	Port B	$V_{CCB} = 0.7\text{ V} \pm 0.05\text{ V}$		101	
		$V_{CCB} = 0.8\text{ V} \pm 0.04\text{ V}$		61	
		$V_{CCB} = 0.9\text{ V} \pm 0.045\text{ V}$		44	
		$V_{CCB} = 1.2\text{ V} \pm 0.1\text{ V}$		30	
		$V_{CCB} = 1.5\text{ V} \pm 0.1\text{ V}$		27	
		$V_{CCB} = 1.8\text{ V} \pm 0.15\text{ V}$		26	
		$V_{CCB} = 2.5\text{ V} \pm 0.2\text{ V}$		25	
		$V_{CCB} = 3.3\text{ V} \pm 0.3\text{ V}$		24	

6.18 Switching Characteristics: $V_{CCA} = 1.8\text{ V}$, $T_A = -40^\circ\text{C}$ to $+125^\circ\text{C}$

 over recommended operating free-air temperature range, $V_{CCA} = 1.8\text{ V}$ (see [Figure 14](#))

PARAMETER	TEST CONDITIONS		MIN	MAX	UNIT
t_{pd} Propagation delay	A-to-B	$V_{CCB} = 0.7\text{ V} \pm 0.05\text{ V}$	0.5	81	ns
		$V_{CCB} = 0.8\text{ V} \pm 0.04\text{ V}$	0.5	41	
		$V_{CCB} = 0.9\text{ V} \pm 0.045\text{ V}$	0.5	24	
		$V_{CCB} = 1.2\text{ V} \pm 0.1\text{ V}$	0.5	10	
		$V_{CCB} = 1.5\text{ V} \pm 0.1\text{ V}$	0.5	8	
		$V_{CCB} = 1.8\text{ V} \pm 0.15\text{ V}$	0.5	7	
		$V_{CCB} = 2.5\text{ V} \pm 0.2\text{ V}$	0.5	5	
		$V_{CCB} = 3.3\text{ V} \pm 0.3\text{ V}$	0.5	5	
	B-to-A	$V_{CCB} = 0.7\text{ V} \pm 0.05\text{ V}$	0.5	53	
		$V_{CCB} = 0.8\text{ V} \pm 0.04\text{ V}$	0.5	26	
		$V_{CCB} = 0.9\text{ V} \pm 0.045\text{ V}$	0.5	16	
		$V_{CCB} = 1.2\text{ V} \pm 0.1\text{ V}$	0.5	9	
		$V_{CCB} = 1.5\text{ V} \pm 0.1\text{ V}$	0.5	7	
		$V_{CCB} = 1.8\text{ V} \pm 0.15\text{ V}$	0.5	7	
$V_{CCB} = 2.5\text{ V} \pm 0.2\text{ V}$		0.5	5		
$V_{CCB} = 3.3\text{ V} \pm 0.3\text{ V}$		0.5	4		
t_{dis} Disable time	Port A	$V_{CCB} = 0.7\text{ V} \pm 0.05\text{ V}$	0.5	18	ns
		$V_{CCB} = 0.8\text{ V} \pm 0.04\text{ V}$	0.5	18	
		$V_{CCB} = 0.9\text{ V} \pm 0.045\text{ V}$	0.5	18	
		$V_{CCB} = 1.2\text{ V} \pm 0.1\text{ V}$	0.5	18	
		$V_{CCB} = 1.5\text{ V} \pm 0.1\text{ V}$	0.5	18	
		$V_{CCB} = 1.8\text{ V} \pm 0.15\text{ V}$	0.5	18	
		$V_{CCB} = 2.5\text{ V} \pm 0.2\text{ V}$	0.5	18	
		$V_{CCB} = 3.3\text{ V} \pm 0.3\text{ V}$	0.5	18	
	Port B	$V_{CCB} = 0.7\text{ V} \pm 0.05\text{ V}$	0.5	136	
		$V_{CCB} = 0.8\text{ V} \pm 0.04\text{ V}$	0.5	96	
		$V_{CCB} = 0.9\text{ V} \pm 0.045\text{ V}$	0.5	75	
		$V_{CCB} = 1.2\text{ V} \pm 0.1\text{ V}$	0.5	28	
		$V_{CCB} = 1.5\text{ V} \pm 0.1\text{ V}$	0.5	20	
		$V_{CCB} = 1.8\text{ V} \pm 0.15\text{ V}$	0.5	18	
$V_{CCB} = 2.5\text{ V} \pm 0.2\text{ V}$		0.5	14		
$V_{CCB} = 3.3\text{ V} \pm 0.3\text{ V}$		0.5	13		

Switching Characteristics: $V_{CCA} = 1.8\text{ V}$, $T_A = -40^\circ\text{C}$ to $+125^\circ\text{C}$ (continued)

 over recommended operating free-air temperature range, $V_{CCA} = 1.8\text{ V}$ (see [Figure 14](#))

PARAMETER	TEST CONDITIONS		MIN	MAX	UNIT
t_{en} Enable time	Port A	$V_{CCB} = 0.7\text{ V} \pm 0.05\text{ V}$		266	ns
		$V_{CCB} = 0.8\text{ V} \pm 0.04\text{ V}$		184	
		$V_{CCB} = 0.9\text{ V} \pm 0.045\text{ V}$		155	
		$V_{CCB} = 1.2\text{ V} \pm 0.1\text{ V}$		42	
		$V_{CCB} = 1.5\text{ V} \pm 0.1\text{ V}$		33	
		$V_{CCB} = 1.8\text{ V} \pm 0.15\text{ V}$		32	
		$V_{CCB} = 2.5\text{ V} \pm 0.2\text{ V}$		24	
		$V_{CCB} = 3.3\text{ V} \pm 0.3\text{ V}$		26	
	Port B	$V_{CCB} = 0.7\text{ V} \pm 0.05\text{ V}$		105	
		$V_{CCB} = 0.8\text{ V} \pm 0.04\text{ V}$		65	
		$V_{CCB} = 0.9\text{ V} \pm 0.045\text{ V}$		48	
		$V_{CCB} = 1.2\text{ V} \pm 0.1\text{ V}$		34	
		$V_{CCB} = 1.5\text{ V} \pm 0.1\text{ V}$		32	
		$V_{CCB} = 1.8\text{ V} \pm 0.15\text{ V}$		31	
		$V_{CCB} = 2.5\text{ V} \pm 0.2\text{ V}$		29	
		$V_{CCB} = 3.3\text{ V} \pm 0.3\text{ V}$		29	

6.19 Switching Characteristics: $V_{CCA} = 2.5\text{ V}$, $T_A = -40^\circ\text{C}$ to $+85^\circ\text{C}$

 over recommended operating free-air temperature range, $V_{CCA} = 2.5\text{ V}$ (see [Figure 8](#))

PARAMETER	TEST CONDITIONS		MIN	MAX	UNIT
t_{pd} Propagation delay	A-to-B	$V_{CCB} = 0.7\text{ V} \pm 0.05\text{ V}$	0.5	80	ns
		$V_{CCB} = 0.8\text{ V} \pm 0.04\text{ V}$	0.5	40	
		$V_{CCB} = 0.9\text{ V} \pm 0.045\text{ V}$	0.5	22	
		$V_{CCB} = 1.2\text{ V} \pm 0.1\text{ V}$	0.5	7	
		$V_{CCB} = 1.5\text{ V} \pm 0.1\text{ V}$	0.5	5	
		$V_{CCB} = 1.8\text{ V} \pm 0.15\text{ V}$	0.5	5	
		$V_{CCB} = 2.5\text{ V} \pm 0.2\text{ V}$	0.5	4	
		$V_{CCB} = 3.3\text{ V} \pm 0.3\text{ V}$	0.5	4	
	B-to-A	$V_{CCB} = 0.7\text{ V} \pm 0.05\text{ V}$	0.5	66	
		$V_{CCB} = 0.8\text{ V} \pm 0.04\text{ V}$	0.5	27	
		$V_{CCB} = 0.9\text{ V} \pm 0.045\text{ V}$	0.5	15	
		$V_{CCB} = 1.2\text{ V} \pm 0.1\text{ V}$	0.5	7	
		$V_{CCB} = 1.5\text{ V} \pm 0.1\text{ V}$	0.5	5	
		$V_{CCB} = 1.8\text{ V} \pm 0.15\text{ V}$	0.5	5	
$V_{CCB} = 2.5\text{ V} \pm 0.2\text{ V}$		0.5	4		
$V_{CCB} = 3.3\text{ V} \pm 0.3\text{ V}$		0.5	3		
t_{dis} Disable time	Port A	$V_{CCB} = 0.7\text{ V} \pm 0.05\text{ V}$	0.5	10	ns
		$V_{CCB} = 0.8\text{ V} \pm 0.04\text{ V}$	0.5	10	
		$V_{CCB} = 0.9\text{ V} \pm 0.045\text{ V}$	0.5	10	
		$V_{CCB} = 1.2\text{ V} \pm 0.1\text{ V}$	0.5	10	
		$V_{CCB} = 1.5\text{ V} \pm 0.1\text{ V}$	0.5	10	
		$V_{CCB} = 1.8\text{ V} \pm 0.15\text{ V}$	0.5	10	
		$V_{CCB} = 2.5\text{ V} \pm 0.2\text{ V}$	0.5	10	
		$V_{CCB} = 3.3\text{ V} \pm 0.3\text{ V}$	0.5	10	
	Port B	$V_{CCB} = 0.7\text{ V} \pm 0.05\text{ V}$	0.5	136	
		$V_{CCB} = 0.8\text{ V} \pm 0.04\text{ V}$	0.5	95	
		$V_{CCB} = 0.9\text{ V} \pm 0.045\text{ V}$	0.5	71	
		$V_{CCB} = 1.2\text{ V} \pm 0.1\text{ V}$	0.5	21	
		$V_{CCB} = 1.5\text{ V} \pm 0.1\text{ V}$	0.5	14	
		$V_{CCB} = 1.8\text{ V} \pm 0.15\text{ V}$	0.5	13	
$V_{CCB} = 2.5\text{ V} \pm 0.2\text{ V}$		0.5	10		
$V_{CCB} = 3.3\text{ V} \pm 0.3\text{ V}$		0.5	10		

Switching Characteristics: $V_{CCA} = 2.5\text{ V}$, $T_A = -40^\circ\text{C}$ to $+85^\circ\text{C}$ (continued)

 over recommended operating free-air temperature range, $V_{CCA} = 2.5\text{ V}$ (see [Figure 8](#))

PARAMETER	TEST CONDITIONS		MIN	MAX	UNIT
t_{en} Enable time	Port A	$V_{CCB} = 0.7\text{ V} \pm 0.05\text{ V}$		254	ns
		$V_{CCB} = 0.8\text{ V} \pm 0.04\text{ V}$		176	
		$V_{CCB} = 0.9\text{ V} \pm 0.045\text{ V}$		147	
		$V_{CCB} = 1.2\text{ V} \pm 0.1\text{ V}$		33	
		$V_{CCB} = 1.5\text{ V} \pm 0.1\text{ V}$		25	
		$V_{CCB} = 1.8\text{ V} \pm 0.15\text{ V}$		24	
		$V_{CCB} = 2.5\text{ V} \pm 0.2\text{ V}$		19	
		$V_{CCB} = 3.3\text{ V} \pm 0.3\text{ V}$		22	
	Port B	$V_{CCB} = 0.7\text{ V} \pm 0.05\text{ V}$		99	
		$V_{CCB} = 0.8\text{ V} \pm 0.04\text{ V}$		55	
		$V_{CCB} = 0.9\text{ V} \pm 0.045\text{ V}$		41	
		$V_{CCB} = 1.2\text{ V} \pm 0.1\text{ V}$		22	
		$V_{CCB} = 1.5\text{ V} \pm 0.1\text{ V}$		24	
		$V_{CCB} = 1.8\text{ V} \pm 0.15\text{ V}$		20	
		$V_{CCB} = 2.5\text{ V} \pm 0.2\text{ V}$		23	
		$V_{CCB} = 3.3\text{ V} \pm 0.3\text{ V}$		19	

6.20 Switching Characteristics: $V_{CCA} = 2.5\text{ V}$, $T_A = -40^\circ\text{C}$ to $+125^\circ\text{C}$

 over recommended operating free-air temperature range, $V_{CCA} = 2.5\text{ V}$ (see [Figure 15](#))

PARAMETER	TEST CONDITIONS		MIN	MAX	UNIT
t_{pd} Propagation delay	A-to-B	$V_{CCB} = 0.7\text{ V} \pm 0.05\text{ V}$	0.5	80	ns
		$V_{CCB} = 0.8\text{ V} \pm 0.04\text{ V}$	0.5	40	
		$V_{CCB} = 0.9\text{ V} \pm 0.045\text{ V}$	0.5	22	
		$V_{CCB} = 1.2\text{ V} \pm 0.1\text{ V}$	0.5	8	
		$V_{CCB} = 1.5\text{ V} \pm 0.1\text{ V}$	0.5	6	
		$V_{CCB} = 1.8\text{ V} \pm 0.15\text{ V}$	0.5	5	
		$V_{CCB} = 2.5\text{ V} \pm 0.2\text{ V}$	0.5	5	
		$V_{CCB} = 3.3\text{ V} \pm 0.3\text{ V}$	0.5	4	
	B-to-A	$V_{CCB} = 0.7\text{ V} \pm 0.05\text{ V}$	0.5	66	
		$V_{CCB} = 0.8\text{ V} \pm 0.04\text{ V}$	0.5	27	
		$V_{CCB} = 0.9\text{ V} \pm 0.045\text{ V}$	0.5	15	
		$V_{CCB} = 1.2\text{ V} \pm 0.1\text{ V}$	0.5	7	
		$V_{CCB} = 1.5\text{ V} \pm 0.1\text{ V}$	0.5	6	
		$V_{CCB} = 1.8\text{ V} \pm 0.15\text{ V}$	0.5	5	
		$V_{CCB} = 2.5\text{ V} \pm 0.2\text{ V}$	0.5	5	
		$V_{CCB} = 3.3\text{ V} \pm 0.3\text{ V}$	0.5	4	
t_{dis} Disable time	Port A disable time	$V_{CCB} = 0.7\text{ V} \pm 0.05\text{ V}$	0.5	13	ns
		$V_{CCB} = 0.8\text{ V} \pm 0.04\text{ V}$	0.5	13	
		$V_{CCB} = 0.9\text{ V} \pm 0.045\text{ V}$	0.5	13	
		$V_{CCB} = 1.2\text{ V} \pm 0.1\text{ V}$	0.5	13	
		$V_{CCB} = 1.5\text{ V} \pm 0.1\text{ V}$	0.5	13	
		$V_{CCB} = 1.8\text{ V} \pm 0.15\text{ V}$	0.5	13	
		$V_{CCB} = 2.5\text{ V} \pm 0.2\text{ V}$	0.5	13	
		$V_{CCB} = 3.3\text{ V} \pm 0.3\text{ V}$	0.5	13	
	Port B disable time	$V_{CCB} = 0.7\text{ V} \pm 0.05\text{ V}$	0.5	136	
		$V_{CCB} = 0.8\text{ V} \pm 0.04\text{ V}$	0.5	95	
		$V_{CCB} = 0.9\text{ V} \pm 0.045\text{ V}$	0.5	75	
		$V_{CCB} = 1.2\text{ V} \pm 0.1\text{ V}$	0.5	27	
		$V_{CCB} = 1.5\text{ V} \pm 0.1\text{ V}$	0.5	20	
		$V_{CCB} = 1.8\text{ V} \pm 0.15\text{ V}$	0.5	17	
		$V_{CCB} = 2.5\text{ V} \pm 0.2\text{ V}$	0.5	13	
		$V_{CCB} = 3.3\text{ V} \pm 0.3\text{ V}$	0.5	12	

Switching Characteristics: $V_{CCA} = 2.5\text{ V}$, $T_A = -40^\circ\text{C}$ to $+125^\circ\text{C}$ (continued)

 over recommended operating free-air temperature range, $V_{CCA} = 2.5\text{ V}$ (see [Figure 15](#))

PARAMETER	TEST CONDITIONS	MIN	MAX	UNIT	
t_{en} Enable time	Port A enable time	$V_{CCB} = 0.7\text{ V} \pm 0.05\text{ V}$		278	ns
		$V_{CCB} = 0.8\text{ V} \pm 0.04\text{ V}$		185	
		$V_{CCB} = 0.9\text{ V} \pm 0.045\text{ V}$		153	
		$V_{CCB} = 1.2\text{ V} \pm 0.1\text{ V}$		39	
		$V_{CCB} = 1.5\text{ V} \pm 0.1\text{ V}$		31	
		$V_{CCB} = 1.8\text{ V} \pm 0.15\text{ V}$		29	
		$V_{CCB} = 2.5\text{ V} \pm 0.2\text{ V}$		23	
		$V_{CCB} = 3.3\text{ V} \pm 0.3\text{ V}$		25	
	Port B enable time	$V_{CCB} = 0.7\text{ V} \pm 0.05\text{ V}$		98	
		$V_{CCB} = 0.8\text{ V} \pm 0.04\text{ V}$		58	
		$V_{CCB} = 0.9\text{ V} \pm 0.045\text{ V}$		40	
		$V_{CCB} = 1.2\text{ V} \pm 0.1\text{ V}$		26	
		$V_{CCB} = 1.5\text{ V} \pm 0.1\text{ V}$		24	
		$V_{CCB} = 1.8\text{ V} \pm 0.15\text{ V}$		23	
		$V_{CCB} = 2.5\text{ V} \pm 0.2\text{ V}$		23	
		$V_{CCB} = 3.3\text{ V} \pm 0.3\text{ V}$		22	

6.21 Switching Characteristics: $V_{CCA} = 3.3 \text{ V} \pm 0.3 \text{ V}$, $T_A = -40^\circ\text{C}$ to $+85^\circ\text{C}$

 over recommended operating free-air temperature range, $V_{CCA} = 3.3 \text{ V} \pm 0.3 \text{ V}$ (see [Figure 7](#))

PARAMETER	TEST CONDITIONS	MIN	MAX	UNIT	
t_{pd} Propagation delay	A-to-B	$V_{CCB} = 0.7 \text{ V} \pm 0.05 \text{ V}$	0.5	79	ns
		$V_{CCB} = 0.8 \text{ V} \pm 0.04 \text{ V}$	0.5	39	
		$V_{CCB} = 0.9 \text{ V} \pm 0.045 \text{ V}$	0.5	22	
		$V_{CCB} = 1.2 \text{ V} \pm 0.1 \text{ V}$	0.5	7	
		$V_{CCB} = 1.5 \text{ V} \pm 0.1 \text{ V}$	0.5	4	
		$V_{CCB} = 1.8 \text{ V} \pm 0.15 \text{ V}$	0.5	4	
		$V_{CCB} = 2.5 \text{ V} \pm 0.2 \text{ V}$	0.5	3	
		$V_{CCB} = 3.3 \text{ V} \pm 0.3 \text{ V}$	0.5	3	
	B-to-A	$V_{CCB} = 0.7 \text{ V} \pm 0.05 \text{ V}$	0.5	144	
		$V_{CCB} = 0.8 \text{ V} \pm 0.04 \text{ V}$	0.5	36	
		$V_{CCB} = 0.9 \text{ V} \pm 0.045 \text{ V}$	0.5	18	
		$V_{CCB} = 1.2 \text{ V} \pm 0.1 \text{ V}$	0.5	7	
		$V_{CCB} = 1.5 \text{ V} \pm 0.1 \text{ V}$	0.5	5	
		$V_{CCB} = 1.8 \text{ V} \pm 0.15 \text{ V}$	0.5	4	
$V_{CCB} = 2.5 \text{ V} \pm 0.2 \text{ V}$		0.5	4		
$V_{CCB} = 3.3 \text{ V} \pm 0.3 \text{ V}$		0.5	3		
t_{dis} Disable time	Port A	$V_{CCB} = 0.7 \text{ V} \pm 0.05 \text{ V}$	0.5	9	ns
		$V_{CCB} = 0.8 \text{ V} \pm 0.04 \text{ V}$	0.5	9	
		$V_{CCB} = 0.9 \text{ V} \pm 0.045 \text{ V}$	0.5	9	
		$V_{CCB} = 1.2 \text{ V} \pm 0.1 \text{ V}$	0.5	9	
		$V_{CCB} = 1.5 \text{ V} \pm 0.1 \text{ V}$	0.5	9	
		$V_{CCB} = 1.8 \text{ V} \pm 0.15 \text{ V}$	0.5	9	
		$V_{CCB} = 2.5 \text{ V} \pm 0.2 \text{ V}$	0.5	9	
		$V_{CCB} = 3.3 \text{ V} \pm 0.3 \text{ V}$	0.5	9	
	Port B	$V_{CCB} = 0.7 \text{ V} \pm 0.05 \text{ V}$	0.5	136	
		$V_{CCB} = 0.8 \text{ V} \pm 0.04 \text{ V}$	0.5	95	
		$V_{CCB} = 0.9 \text{ V} \pm 0.045 \text{ V}$	0.5	71	
		$V_{CCB} = 1.2 \text{ V} \pm 0.1 \text{ V}$	0.5	21	
		$V_{CCB} = 1.5 \text{ V} \pm 0.1 \text{ V}$	0.5	14	
		$V_{CCB} = 1.8 \text{ V} \pm 0.15 \text{ V}$	0.5	12	
$V_{CCB} = 2.5 \text{ V} \pm 0.2 \text{ V}$		0.5	10		
$V_{CCB} = 3.3 \text{ V} \pm 0.3 \text{ V}$		0.5	10		

Switching Characteristics: $V_{CCA} = 3.3\text{ V} \pm 0.3\text{ V}$, $T_A = -40^\circ\text{C}$ to $+85^\circ\text{C}$ (continued)

 over recommended operating free-air temperature range, $V_{CCA} = 3.3\text{ V} \pm 0.3\text{ V}$ (see [Figure 7](#))

PARAMETER	TEST CONDITIONS	MIN	MAX	UNIT	
t_{en} Enable time	Port A	$V_{CCB} = 0.7\text{ V} \pm 0.05\text{ V}$		331	ns
		$V_{CCB} = 0.8\text{ V} \pm 0.04\text{ V}$		185	
		$V_{CCB} = 0.9\text{ V} \pm 0.045\text{ V}$		149	
		$V_{CCB} = 1.2\text{ V} \pm 0.1\text{ V}$		33	
		$V_{CCB} = 1.5\text{ V} \pm 0.1\text{ V}$		25	
		$V_{CCB} = 1.8\text{ V} \pm 0.15\text{ V}$		23	
		$V_{CCB} = 2.5\text{ V} \pm 0.2\text{ V}$		19	
		$V_{CCB} = 3.3\text{ V} \pm 0.3\text{ V}$		22	
	Port B	$V_{CCB} = 0.7\text{ V} \pm 0.05\text{ V}$		98	
		$V_{CCB} = 0.8\text{ V} \pm 0.04\text{ V}$		58	
		$V_{CCB} = 0.9\text{ V} \pm 0.045\text{ V}$		41	
		$V_{CCB} = 1.2\text{ V} \pm 0.1\text{ V}$		26	
		$V_{CCB} = 1.5\text{ V} \pm 0.1\text{ V}$		23	
		$V_{CCB} = 1.8\text{ V} \pm 0.15\text{ V}$		23	
		$V_{CCB} = 2.5\text{ V} \pm 0.2\text{ V}$		22	
		$V_{CCB} = 3.3\text{ V} \pm 0.3\text{ V}$		22	

6.22 Switching Characteristics: $V_{CCA} = 3.3\text{ V} \pm 0.3\text{ V}$, $T_A = -40^\circ\text{C}$ to $+125^\circ\text{C}$

 over recommended operating free-air temperature range, $V_{CCA} = 3.3\text{ V} \pm 0.3\text{ V}$ (see [Figure 16](#))

PARAMETER		TEST CONDITIONS	MIN	MAX	UNIT	
t_{pd}	Propagation delay	A-to-B	$V_{CCB} = 0.7\text{ V} \pm 0.05\text{ V}$	0.5	79	ns
			$V_{CCB} = 0.8\text{ V} \pm 0.04\text{ V}$	0.5	39	
			$V_{CCB} = 0.9\text{ V} \pm 0.045\text{ V}$	0.5	22	
			$V_{CCB} = 1.2\text{ V} \pm 0.1\text{ V}$	0.5	7	
			$V_{CCB} = 1.5\text{ V} \pm 0.1\text{ V}$	0.5	5	
			$V_{CCB} = 1.8\text{ V} \pm 0.15\text{ V}$	0.5	4	
			$V_{CCB} = 2.5\text{ V} \pm 0.2\text{ V}$	0.5	4	
			$V_{CCB} = 3.3\text{ V} \pm 0.3\text{ V}$	0.5	4	
	B-to-A	$V_{CCB} = 0.7\text{ V} \pm 0.05\text{ V}$	0.5	144		
		$V_{CCB} = 0.8\text{ V} \pm 0.04\text{ V}$	0.5	36		
		$V_{CCB} = 0.9\text{ V} \pm 0.045\text{ V}$	0.5	18		
		$V_{CCB} = 1.2\text{ V} \pm 0.1\text{ V}$	0.5	8		
		$V_{CCB} = 1.5\text{ V} \pm 0.1\text{ V}$	0.5	6		
		$V_{CCB} = 1.8\text{ V} \pm 0.15\text{ V}$	0.5	5		
		$V_{CCB} = 2.5\text{ V} \pm 0.2\text{ V}$	0.5	4		
		$V_{CCB} = 3.3\text{ V} \pm 0.3\text{ V}$	0.5	4		
t_{dis}	Disable time	Port A	$V_{CCB} = 0.7\text{ V} \pm 0.05\text{ V}$	0.5	12	ns
			$V_{CCB} = 0.8\text{ V} \pm 0.04\text{ V}$	0.5	12	
			$V_{CCB} = 0.9\text{ V} \pm 0.045\text{ V}$	0.5	12	
			$V_{CCB} = 1.2\text{ V} \pm 0.1\text{ V}$	0.5	12	
			$V_{CCB} = 1.5\text{ V} \pm 0.1\text{ V}$	0.5	12	
			$V_{CCB} = 1.8\text{ V} \pm 0.15\text{ V}$	0.5	12	
			$V_{CCB} = 2.5\text{ V} \pm 0.2\text{ V}$	0.5	12	
			$V_{CCB} = 3.3\text{ V} \pm 0.3\text{ V}$	0.5	12	
	Port B	$V_{CCB} = 0.7\text{ V} \pm 0.05\text{ V}$	0.5	136		
		$V_{CCB} = 0.8\text{ V} \pm 0.04\text{ V}$	0.5	95		
		$V_{CCB} = 0.9\text{ V} \pm 0.045\text{ V}$	0.5	75		
		$V_{CCB} = 1.2\text{ V} \pm 0.1\text{ V}$	0.5	27		
		$V_{CCB} = 1.5\text{ V} \pm 0.1\text{ V}$	0.5	19		
		$V_{CCB} = 1.8\text{ V} \pm 0.15\text{ V}$	0.5	17		
		$V_{CCB} = 2.5\text{ V} \pm 0.2\text{ V}$	0.5	13		
		$V_{CCB} = 3.3\text{ V} \pm 0.3\text{ V}$	0.5	12		

Switching Characteristics: $V_{CCA} = 3.3\text{ V} \pm 0.3\text{ V}$, $T_A = -40^\circ\text{C}$ to $+125^\circ\text{C}$ (continued)

 over recommended operating free-air temperature range, $V_{CCA} = 3.3\text{ V} \pm 0.3\text{ V}$ (see [Figure 16](#))

PARAMETER	TEST CONDITIONS	MIN	MAX	UNIT	
t_{en} Enable time	Port A	$V_{CCB} = 0.7\text{ V} \pm 0.05\text{ V}$		356	ns
		$V_{CCB} = 0.8\text{ V} \pm 0.04\text{ V}$		93	
		$V_{CCB} = 0.9\text{ V} \pm 0.045\text{ V}$		156	
		$V_{CCB} = 1.2\text{ V} \pm 0.1\text{ V}$		40	
		$V_{CCB} = 1.5\text{ V} \pm 0.1\text{ V}$		31	
		$V_{CCB} = 1.8\text{ V} \pm 0.15\text{ V}$		29	
		$V_{CCB} = 2.5\text{ V} \pm 0.2\text{ V}$		22	
		$V_{CCB} = 3.3\text{ V} \pm 0.3\text{ V}$		24	
	Port B	$V_{CCB} = 0.7\text{ V} \pm 0.05\text{ V}$		99	
		$V_{CCB} = 0.8\text{ V} \pm 0.04\text{ V}$		59	
		$V_{CCB} = 0.9\text{ V} \pm 0.045\text{ V}$		42	
		$V_{CCB} = 1.2\text{ V} \pm 0.1\text{ V}$		27	
		$V_{CCB} = 1.5\text{ V} \pm 0.1\text{ V}$		25	
		$V_{CCB} = 1.8\text{ V} \pm 0.15\text{ V}$		24	
		$V_{CCB} = 2.5\text{ V} \pm 0.2\text{ V}$		24	
		$V_{CCB} = 3.3\text{ V} \pm 0.3\text{ V}$		24	

6.23 Operating Characteristics

 $T_A = 25^\circ\text{C}$

PARAMETER	TEST CONDITIONS		MIN	TYP	MAX	UNIT
C_{pdA} Power dissipation capacitance per transceiver	$C_L = 0\text{ pF}$, $f = 1\text{ MHz}$, $t_r = t_f = 1\text{ ns}$	A-port input, B-port output	$V_{CCA} = V_{CCB} = 0.7\text{ V}$		1.3	pF
			$V_{CCA} = V_{CCB} = 0.8\text{ V}$		1.3	
			$V_{CCA} = V_{CCB} = 0.9\text{ V}$		1.3	
			$V_{CCA} = V_{CCB} = 1.2\text{ V}$		1.3	
			$V_{CCA} = V_{CCB} = 1.5\text{ V}$		1.3	
			$V_{CCA} = V_{CCB} = 1.8\text{ V}$		1.4	
			$V_{CCA} = V_{CCB} = 2.5\text{ V}$		1.7	
			$V_{CCA} = V_{CCB} = 3.3\text{ V}$		2.1	
		B-port input, A-port output	$V_{CCA} = V_{CCB} = 0.7\text{ V}$		9.2	
			$V_{CCA} = V_{CCB} = 0.8\text{ V}$		9.4	
			$V_{CCA} = V_{CCB} = 0.9\text{ V}$		9.4	
			$V_{CCA} = V_{CCB} = 1.2\text{ V}$		9.8	
			$V_{CCA} = V_{CCB} = 1.5\text{ V}$		10.1	
			$V_{CCA} = V_{CCB} = 1.8\text{ V}$		11.0	
			$V_{CCA} = V_{CCB} = 2.5\text{ V}$		14.4	
			$V_{CCA} = V_{CCB} = 3.3\text{ V}$		18.6	
C_{pdB} Power dissipation capacitance per transceiver	$C_L = 0\text{ pF}$, $f = 1\text{ MHz}$, $t_r = t_f = 1\text{ ns}$	A-port input, B-port output	$V_{CCA} = V_{CCB} = 0.7\text{ V}$		9.2	pF
			$V_{CCA} = V_{CCB} = 0.8\text{ V}$		9.3	
			$V_{CCA} = V_{CCB} = 0.9\text{ V}$		9.4	
			$V_{CCA} = V_{CCB} = 1.2\text{ V}$		9.7	
			$V_{CCA} = V_{CCB} = 1.5\text{ V}$		10.1	
			$V_{CCA} = V_{CCB} = 1.8\text{ V}$		11.0	
			$V_{CCA} = V_{CCB} = 2.5\text{ V}$		14.4	
			$V_{CCA} = V_{CCB} = 3.3\text{ V}$		18.3	
		B-port input, A-port output	$V_{CCA} = V_{CCB} = 0.7\text{ V}$		1.3	
			$V_{CCA} = V_{CCB} = 0.8\text{ V}$		1.3	
			$V_{CCA} = V_{CCB} = 0.9\text{ V}$		1.3	
			$V_{CCA} = V_{CCB} = 1.2\text{ V}$		1.3	
			$V_{CCA} = V_{CCB} = 1.5\text{ V}$		1.3	
			$V_{CCA} = V_{CCB} = 1.8\text{ V}$		1.4	
			$V_{CCA} = V_{CCB} = 2.5\text{ V}$		1.7	
			$V_{CCA} = V_{CCB} = 3.3\text{ V}$		2.1	

6.24 Typical Characteristics

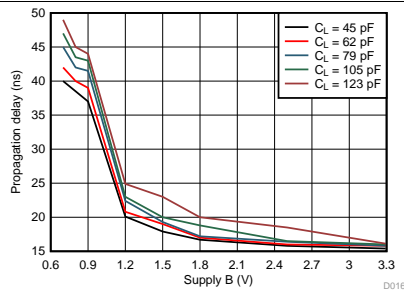

$T_A = 25^\circ\text{C}$ $V_{CCA} = 0.7\text{ V}$

Figure 1. Typical Propagation Delay of Low-to-High (A to B) vs Load Capacitance

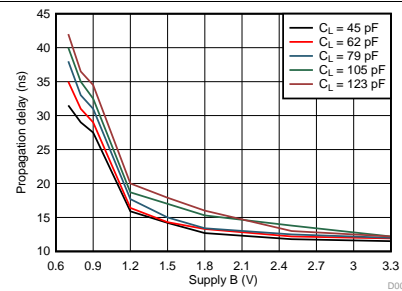

$T_A = 25^\circ\text{C}$ $V_{CCA} = 0.8\text{ V}$

Figure 2. Typical Propagation Delay of Low-to-High (A to B) vs Load Capacitance

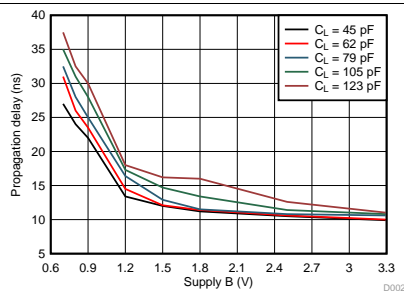

$T_A = 25^\circ\text{C}$ $V_{CCA} = 0.9\text{ V}$

Figure 3. Typical Propagation Delay of Low-to-High (A to B) vs Load Capacitance

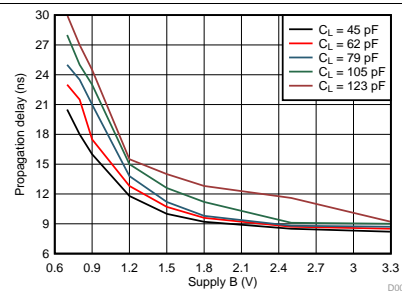

$T_A = 25^\circ\text{C}$ $V_{CCA} = 1.2\text{ V}$

Figure 4. Typical Propagation Delay of Low-to-High (A to B) vs Load Capacitance

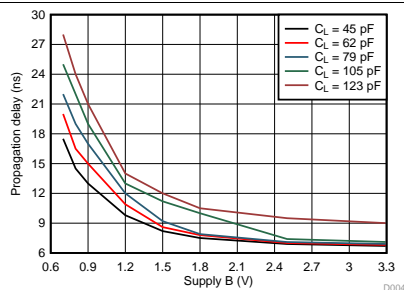

$T_A = 25^\circ\text{C}$ $V_{CCA} = 1.5\text{ V}$

Figure 5. Typical Propagation Delay of Low-to-High (A to B) vs Load Capacitance

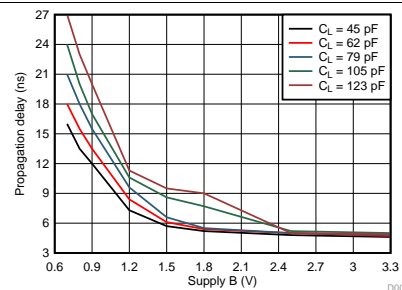

$T_A = 25^\circ\text{C}$ $V_{CCA} = 1.8\text{ V}$

Figure 6. Typical Propagation Delay of Low-to-High (A to B) vs Load Capacitance

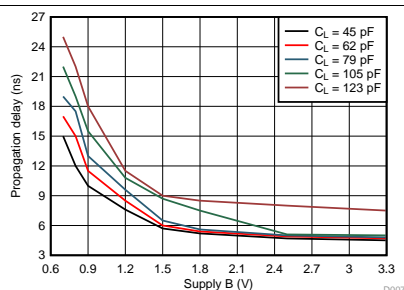

$T_A = 25^\circ\text{C}$ $V_{CCA} = 3.3\text{ V}$

Figure 7. Typical Propagation Delay of Low-to-High (A to B) vs Load Capacitance

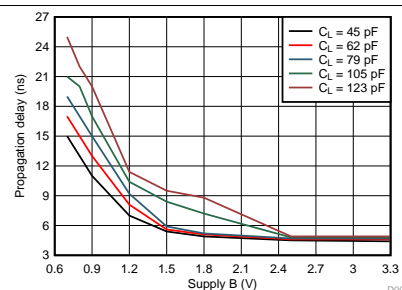

$T_A = 25^\circ\text{C}$ $V_{CCA} = 2.5\text{ V}$

Figure 8. Typical Propagation Delay of Low-to-High (A to B) vs Load Capacitance

Typical Characteristics (continued)

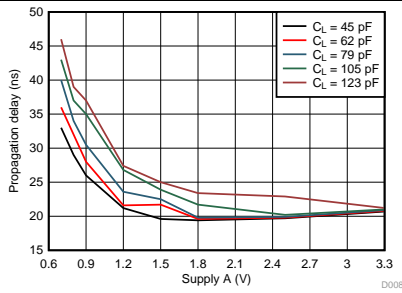

$T_A = 25^\circ\text{C}$ $V_{CCA} = 0.7\text{ V}$

Figure 9. Typical Propagation Delay of Low-to-High (B to A) vs Load Capacitance

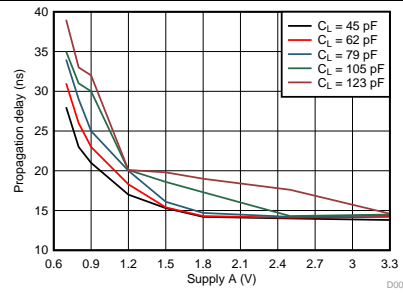

$T_A = 25^\circ\text{C}$ $V_{CCA} = 0.8\text{ V}$

Figure 10. Typical Propagation Delay of Low-to-High (B to A) vs Load Capacitance

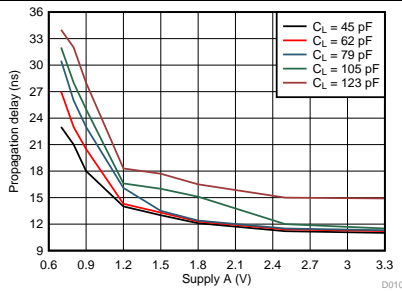

$T_A = 25^\circ\text{C}$ $V_{CCA} = 0.9\text{ V}$

Figure 11. Typical Propagation Delay of Low-to-High (B to A) vs Load Capacitance

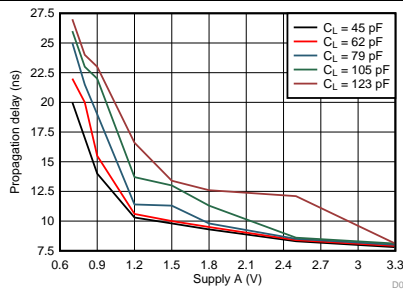

$T_A = 25^\circ\text{C}$ $V_{CCA} = 1.2\text{ V}$

Figure 12. Typical Propagation Delay of Low-to-High (B to A) vs Load Capacitance

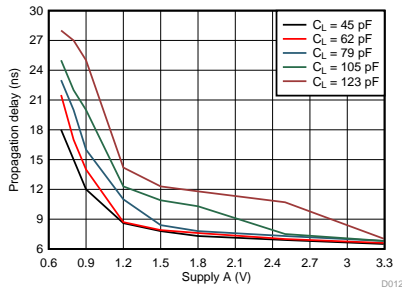

$T_A = 25^\circ\text{C}$ $V_{CCA} = 1.5\text{ V}$

Figure 13. Typical Propagation Delay of Low-to-High (B to A) vs Load Capacitance

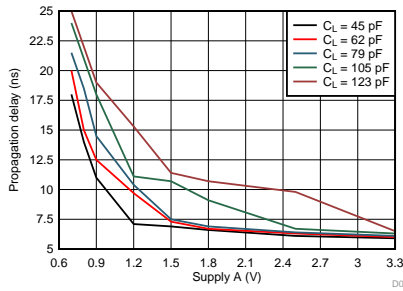

$T_A = 25^\circ\text{C}$ $V_{CCA} = 1.8\text{ V}$

Figure 14. Typical Propagation Delay of Low-to-High (B to A) vs Load Capacitance

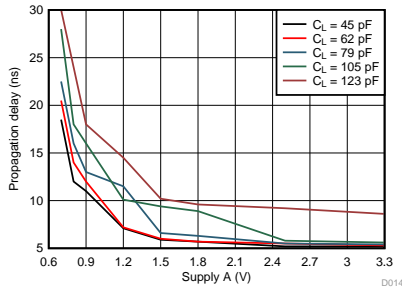

$T_A = 25^\circ\text{C}$ $V_{CCA} = 2.5\text{ V}$

Figure 15. Typical Propagation Delay of Low-to-High (B to A) vs Load Capacitance

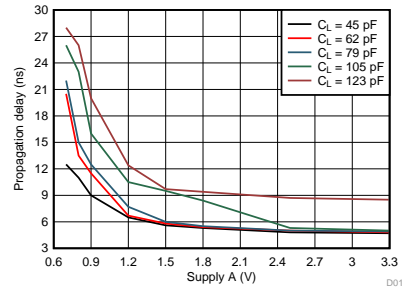

$T_A = 25^\circ\text{C}$ $V_{CCA} = 3.3\text{ V}$

Figure 16. Typical Propagation Delay of Low-to-High (B to A) vs Load Capacitance

7 Parameter Measurement Information

7.1 Load Circuit and Voltage Waveforms

Unless otherwise noted, all input pulses are supplied by generators having the following characteristics:

- $f = 1 \text{ MHz}$
- $Z_O = 50 \Omega$
- $dv/dt \leq 1 \text{ ns/V}$

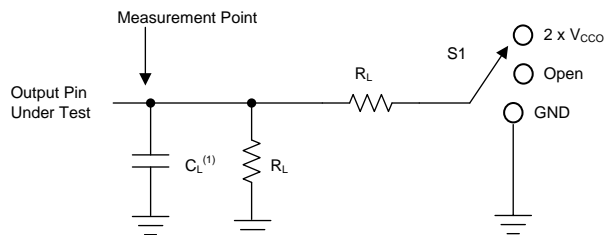

(1) C_L includes probe and jig capacitance.

Figure 17. Load Circuit

Table 1. Load Circuit Conditions

Parameter	V_{CCO}	R_L	C_L	S_1	V_{TP}
$\Delta t/\Delta v$ Input transition rise or fall rate	0.65 V – 3.6 V	1 M Ω	15 pF	Open	N/A
t_{pd} Propagation (delay) time	1.1 V – 3.6 V	2 k Ω	15 pF	Open	N/A
	0.65 V – 0.95 V	20 k Ω	15 pF	Open	N/A
t_{en}, t_{dis} Enable time, disable time	3 V – 3.6 V	2 k Ω	15 pF	$2 \times V_{CCO}$	0.3 V
	1.65 V – 2.7 V	2 k Ω	15 pF	$2 \times V_{CCO}$	0.15 V
	1.1 V – 1.6 V	2 k Ω	15 pF	$2 \times V_{CCO}$	0.1 V
	0.65 V – 0.95 V	20 k Ω	15 pF	$2 \times V_{CCO}$	0.1 V
t_{en}, t_{dis} Enable time, disable time	3 V – 3.6 V	2 k Ω	15 pF	GND	0.3 V
	1.65 V – 2.7 V	2 k Ω	15 pF	GND	0.15 V
	1.1 V – 1.6 V	2 k Ω	15 pF	GND	0.1 V
	0.65 V – 0.95 V	20 k Ω	15 pF	GND	0.1 V

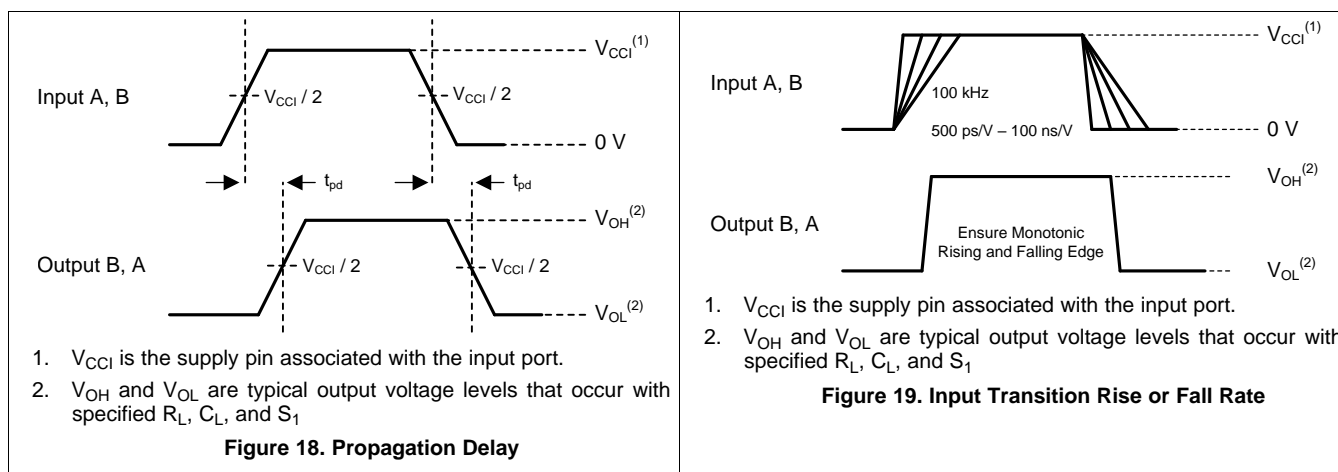
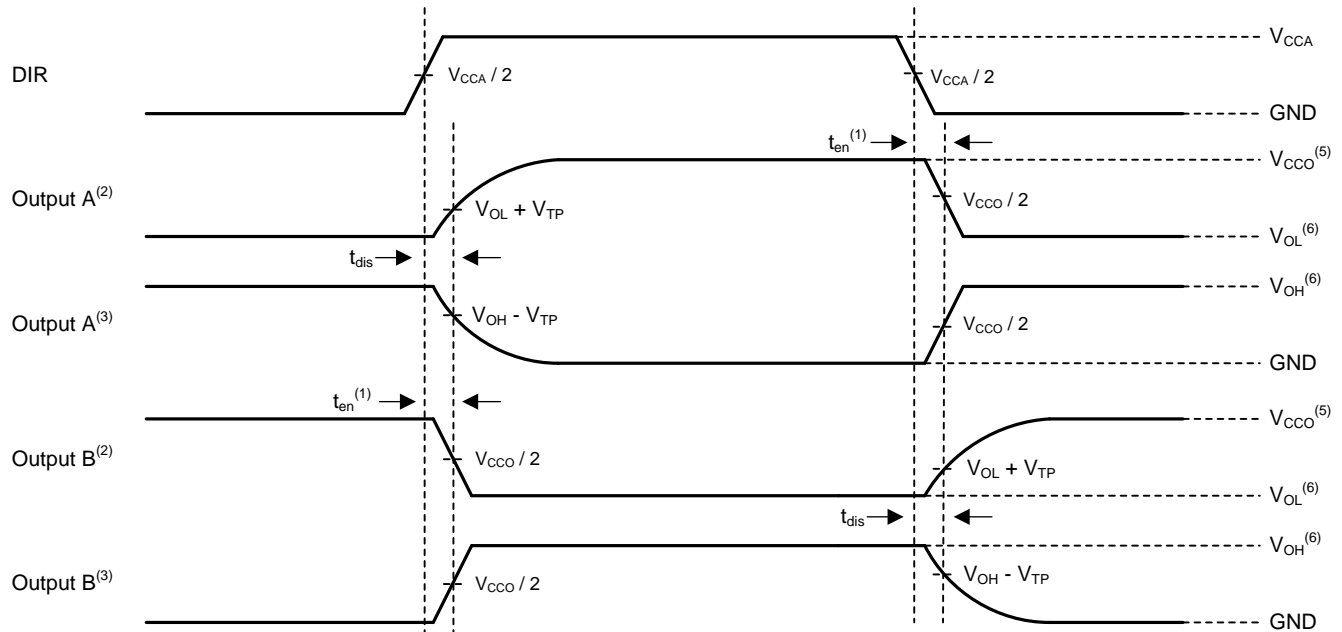

Figure 18. Propagation Delay

Figure 19. Input Transition Rise or Fall Rate



1. Illustrative purposes only. Enable Time is a calculation as described in the data sheet.
2. Output waveform on the condition that input is driven to a valid Logic Low.
3. Output waveform on the condition that input is driven to a valid Logic High.
4. V_{CCI} is the supply pin associated with the input port
5. V_{CCO} is the supply pin associated with the output port.
6. V_{OH} and V_{OL} are typical output voltage levels that occur with specified R_L , C_L , and S_1

Figure 20. Disable and Enable Time

8 Detailed Description

8.1 Overview

The SN74AXC1T45 is single-bit, dual-supply, noninverting voltage level translation. Pin A and the direction control pin are support by V_{CCA} and pin B is support by V_{CCB} . The A port can accept I/O voltages ranging from 0.65 V to 3.6 V, and the B port can accept I/O voltages from 0.65 V to 3.6 V. A high logic on the DIR pin allows data transmission from A to B and a logic low on the DIR pin allows data transmission from B to A.

8.2 Functional Block Diagram

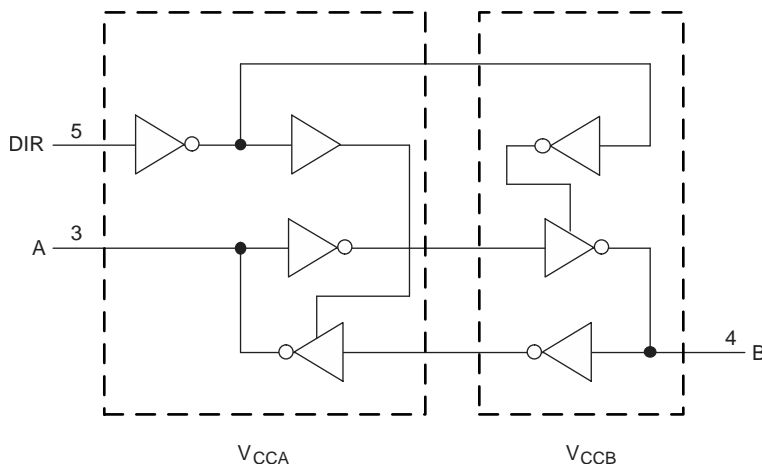

8.3 Feature Description

8.3.1 Fully Configurable Dual-Rail Design Allows Each Port to Operate Over the Full 0.65-V to 3.6-V Power-Supply Range

Both the V_{CCA} and V_{CCB} pins can be supplied at any voltage from 0.65 V to 3.6 V, making the device suitable for translating between any of the voltage nodes (0.7 V, 0.8 V, 0.9 V, 1.2 V, 1.8 V, 2.5 V and 3.3 V).

8.3.2 Support High-Speed Translation

The SN74AXC1T45 device can support high data-rate applications. The translated signal data rate can be up to 500 Mbps when signal is translated from 1.8 V to 3.3 V.

8.3.3 I_{off} Supports Partial-Power-Down Mode Operation

The I_{off} circuit prevents backflow current by disabling the I/O output circuits when the device is in partial-power-down mode.

8.4 Device Functional Modes

Table 2 lists the device functions for the DIR input.

Table 2. Function Table

INPUT ⁽¹⁾ DIR	OPERATION
L	B data to A bus
H	A data to B bus

(1) Input circuits of the data I/Os always are active.

9 Application and Implementation

NOTE

Information in the following applications sections is not part of the TI component specification, and TI does not warrant its accuracy or completeness. TI's customers are responsible for determining suitability of components for their purposes. Customers should validate and test their design implementation to confirm system functionality.

9.1 Application Information

The SN74AXC1T45 device can be used in level-translation applications for interfacing devices or systems with one another when they are operating at different interface voltages. The maximum data rate can be up to 500 Mbps when the device translate signal is from 1.8 V to 3.3 V.

9.1.1 Enable Times

Calculate the enable times for the SN74AXC1T45 using the following formulas:

$$t_{PZH} \text{ (DIR to A)} = t_{PLZ} \text{ (DIR to B)} + t_{PLH} \text{ (B to A)} \tag{1}$$

$$t_{PZL} \text{ (DIR to A)} = t_{PHZ} \text{ (DIR to B)} + t_{PHL} \text{ (B to A)} \tag{2}$$

$$t_{PZH} \text{ (DIR to B)} = t_{PLZ} \text{ (DIR to A)} + t_{PLH} \text{ (A to B)} \tag{3}$$

$$t_{PZL} \text{ (DIR to B)} = t_{PHZ} \text{ (DIR to A)} + t_{PHL} \text{ (A to B)} \tag{4}$$

In a bidirectional application, these enable times provide the maximum delay time from the time the DIR bit is switched until an output is expected. For example, if the SN74AXC1T45 initially is transmitting from A to B, then the DIR bit is switched; the B port of the device must be disabled before presenting it with an input. After the B port has been disabled, an input signal applied to it appears on the corresponding A port after the specified propagation delay.

9.2 Typical Applications

9.2.1 Unidirectional Logic Level-Shifting Application

Figure 21 shows an example of the SN74AXC1T45 being used in a unidirectional logic level-shifting application.

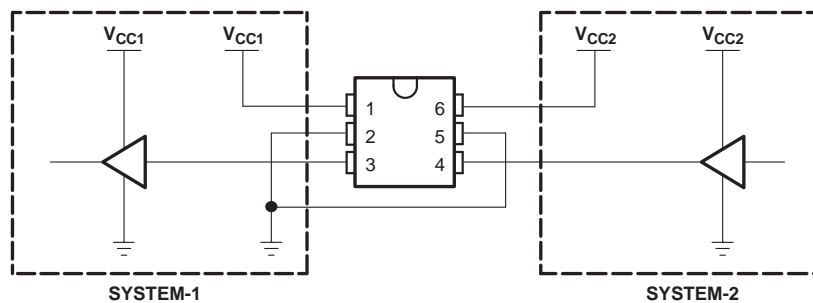

Figure 21. Unidirectional Logic Level-Shifting Application

Table 3. Unidirectional Level Shifting Function

PIN	NAME	FUNCTION	DESCRIPTION
1	V _{CCA}	V _{CC1}	SYSTEM-1 supply voltage (0.65 V to 3.6 V)
2	GND	GND	Device GND
3	A	OUT	Output level depends on V _{CC1} voltage.
4	B	IN	Input threshold value depends on V _{CC2} voltage.
5	DIR	DIR	GND (low level) determines B-port to A-port direction.
6	V _{CCB}	V _{CC2}	SYSTEM-2 supply voltage (0.65 V to 3.6 V)

9.2.1.1 Design Requirements

For this design example, use the parameters listed in Table 4.

Table 4. Design Parameters

DESIGN PARAMETERS	EXAMPLE VALUES
Input voltage range	0.65 V to 3.6 V
Output voltage range	0.65 V to 3.6 V

9.2.1.2 Detailed Design Procedure

To begin the design process, determine the following:

- Input voltage range
 - Use the supply voltage of the device that is driving the SN74AXC1T45 device to determine the input voltage range. For a valid logic-high, the value must exceed the high-level input voltage (V_{IH}) of the input port. For a valid logic low the value must be less than the low-level input voltage (V_{IL}) of the input port.
- Output voltage range
 - Use the supply voltage of the device that the SN74AXC1T45 device is driving to determine the output voltage range.

9.2.1.3 Application Curve

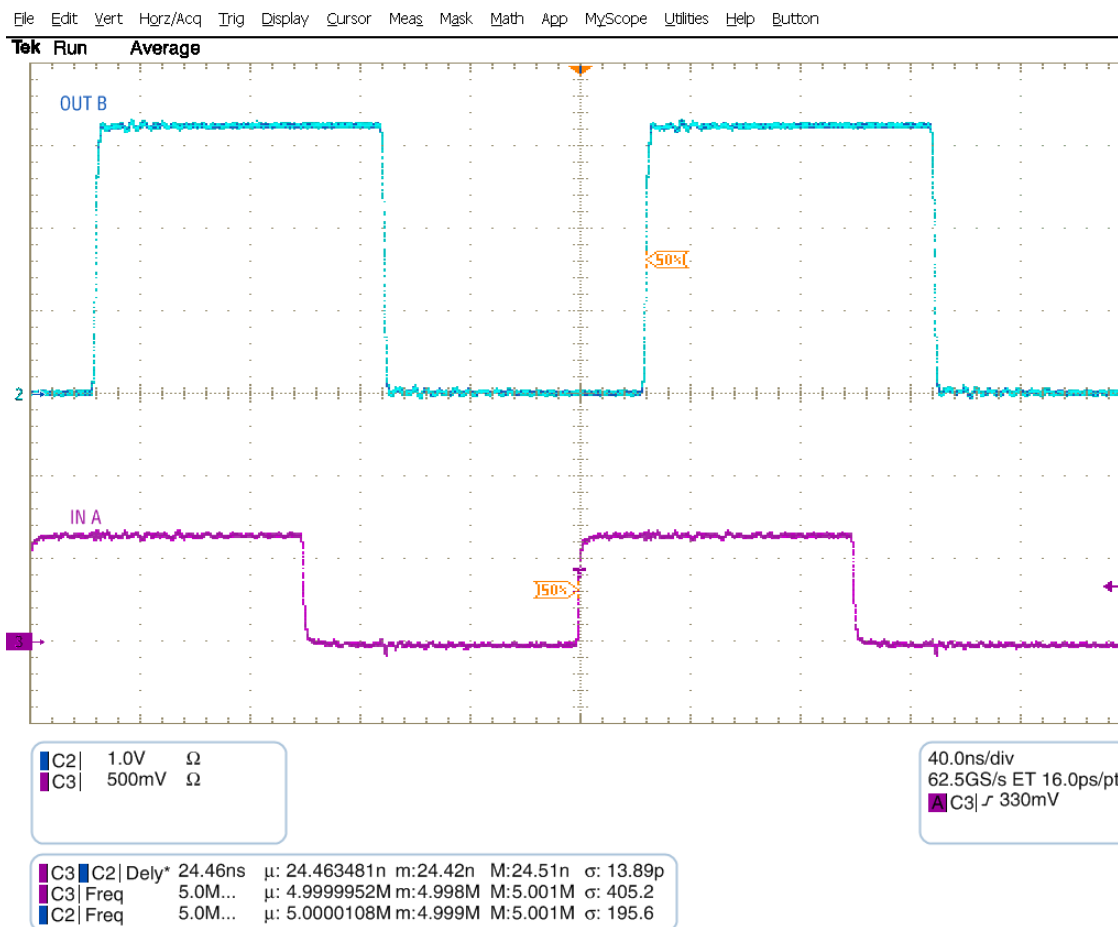

Figure 22. Up Translation at 2.5 MHz (0.7 V to 3.3 V)

9.2.2 Bidirectional Logic Level-Shifting Application

Figure 23 shows the SN74AXC1T45 being used in a bidirectional logic level-shifting application. Because the SN74AXC1T45 does not have an output-enable (OE) pin, the system designer should take precautions to avoid bus contention between SYSTEM-1 and SYSTEM-2 when changing directions.

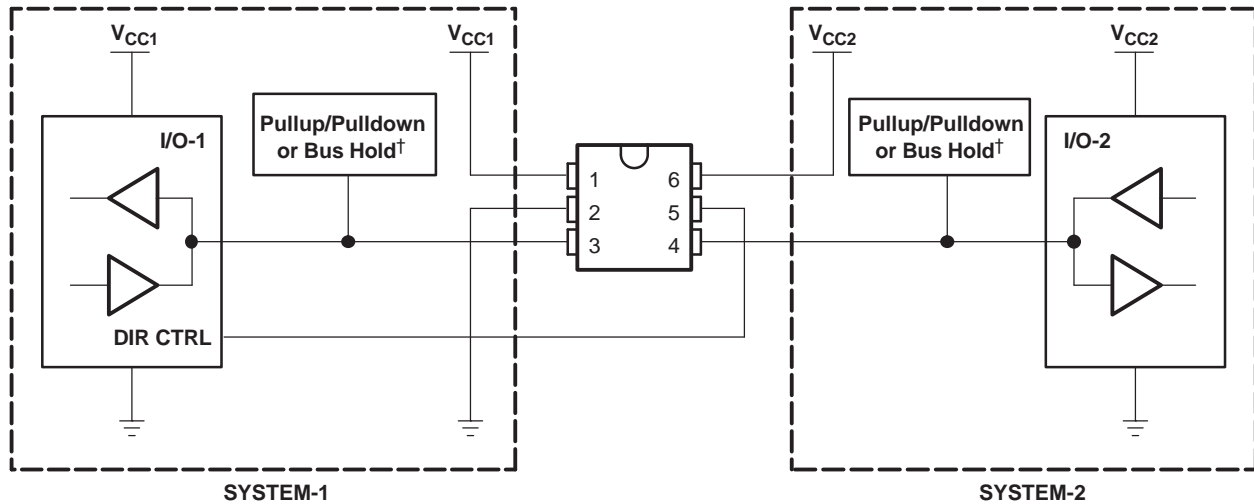

Figure 23. Bidirectional Logic Level-Shifting Application

Table 5 lists the data transmission from SYSTEM-1 to SYSTEM-2 and then from SYSTEM-2 to SYSTEM-1.

Table 5. Data Transmission: SYSTEM-1 and SYSTEM-2

STATE	DIR CTRL	I/O-1	I/O-2	DESCRIPTION
1	H	Out	In	SYSTEM-1 data to SYSTEM-2
2	H	Hi-Z	Hi-Z	SYSTEM-2 is getting ready to send data to SYSTEM-1. I/O-1 and I/O-2 are disabled. The bus-line state depends on pullup or pulldown resistors. ⁽¹⁾
3	L	Hi-Z	Hi-Z	DIR bit is flipped. I/O-1 and I/O-2 still are disabled. The bus-line state depends on pullup or pulldown resistors. ⁽¹⁾
4	L	In	Out	SYSTEM-2 data to SYSTEM-1

(1) SYSTEM-1 and SYSTEM-2 must use the same conditions, essentially, both pullup or both pulldown.

9.2.2.1 Design Requirements

Refer to [Design Requirements](#).

9.2.2.2 Detailed Design Procedure

Refer to [Detailed Design Procedure](#).

9.2.2.3 Application Curve

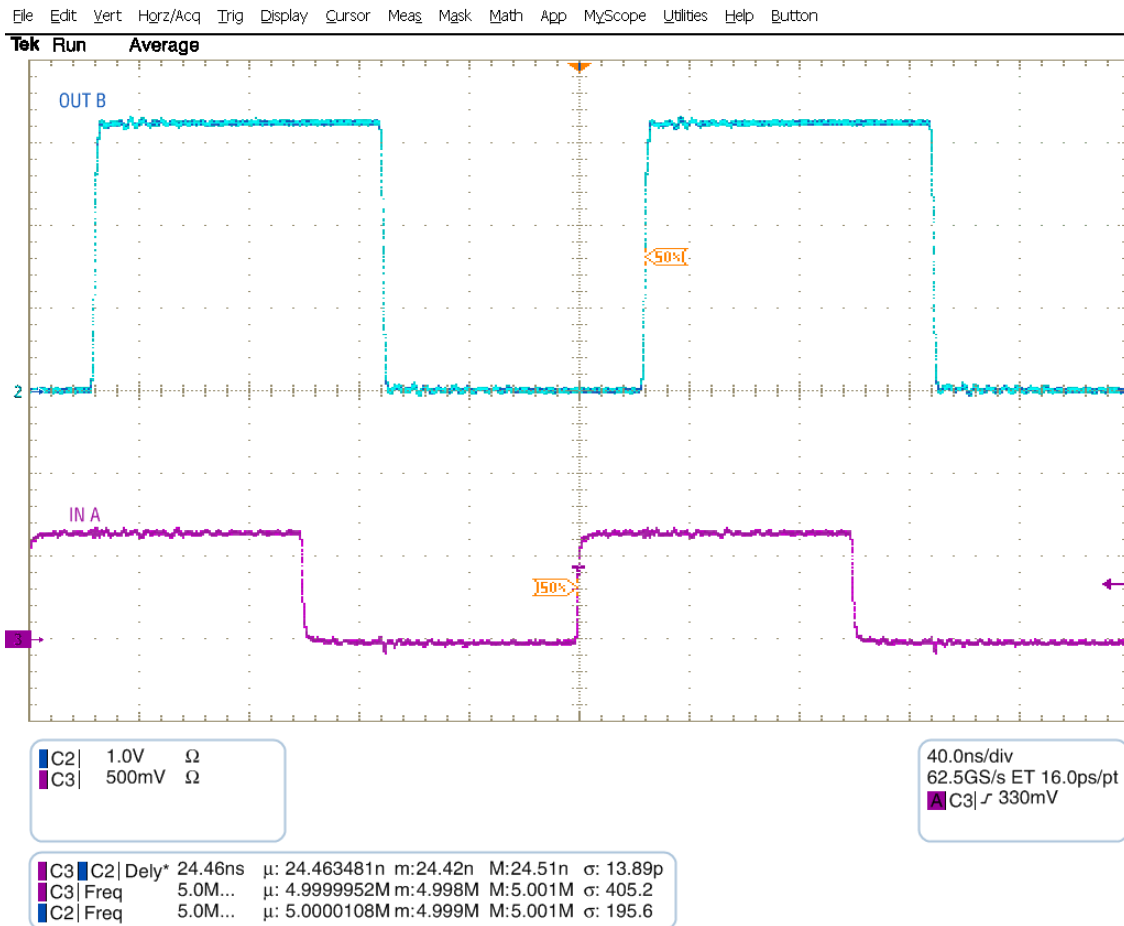

Figure 24. Up Translation at 2.5 MHz (0.7 V to 3.3 V)

10 Power Supply Recommendations

The SN74AXC1T45 device uses two separate configurable power-supply rails, V_{CCA} and V_{CCB} . The V_{CCA} power-supply rail accepts any supply voltage from 0.65 V to 3.6 V and the V_{CCB} power-supply rail accepts any supply voltage from 0.65 V to 3.6 V. The A port and B port are designed to track the V_{CCA} and V_{CCB} supplies respectively allowing for low-voltage, bidirectional translation between any of the 0.7-V, 0.8-V, 0.9-V, 1.2-V, 1.5-V, 1.8-V, 2.5-V, and 3.3-V voltage nodes.

10.1 Power-Up Considerations

A proper power-up sequence must be followed to avoid excessive supply current, bus contention, oscillations, or other anomalies. To guard against such power-up problems, take the following precautions:

1. Connect the ground before any supply voltage is applied.
2. Power up the V_{CCA} and V_{CCB} supplies. The V_{CCA} and V_{CCB} supplies can be ramped in any order.

11 Layout

11.1 Layout Guidelines

To ensure reliability of the device, following common printed-circuit board layout guidelines is recommended:

- Bypass capacitors should be used on power supplies.
- Short trace lengths should be used to avoid excessive loading.
- Placing pads on the signal paths for loading capacitors or pullup resistors to help adjust rise and fall times of signals depending on the system requirements.

11.2 Layout Example

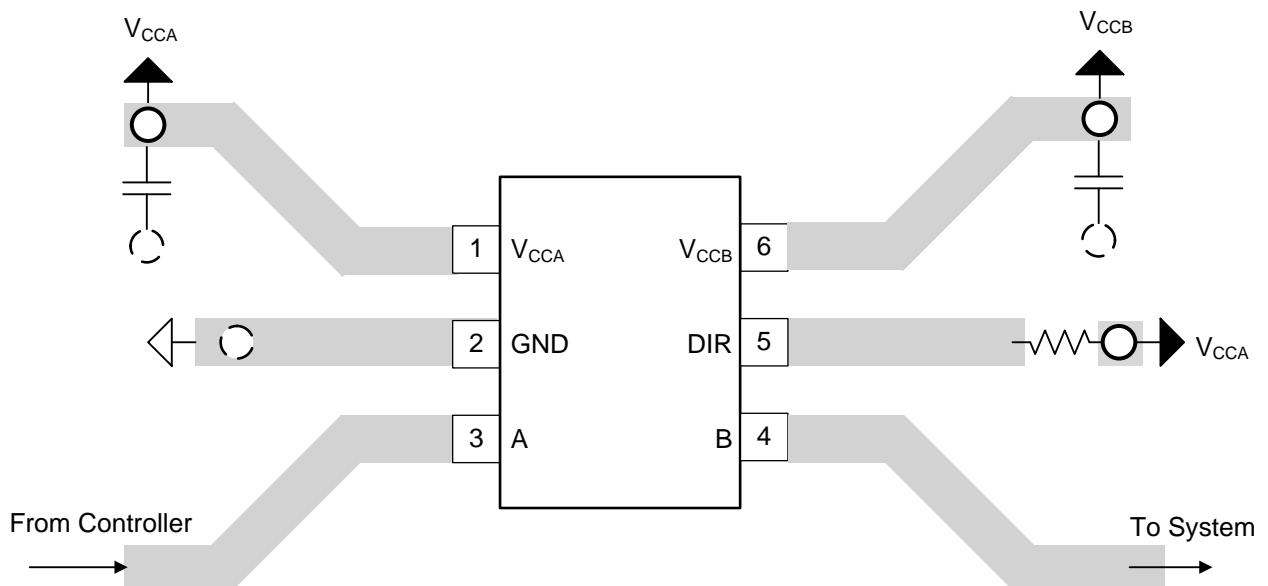
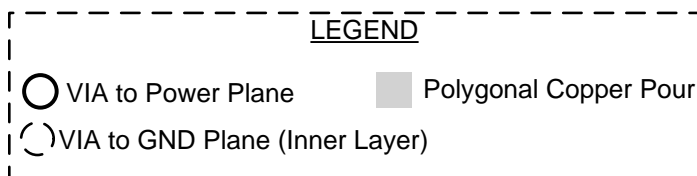

Figure 25. PCB Layout Example

12 Device and Documentation Support

12.1 Documentation Support

12.1.1 Related Documentation

For related documentation see the following:

- Texas Instruments, [Evaluate SN74AXC1T45DRL Using a Generic EVM](#) application report
- Texas Instruments, [Implications of Slow or Floating CMOS Inputs](#) application report
- Texas Instruments, [Power Sequencing for the AXC Family of Devices](#) application report

12.2 Receiving Notification of Documentation Updates

To receive notification of documentation updates, navigate to the device product folder on ti.com. In the upper right corner, click on *Alert me* to register and receive a weekly digest of any product information that has changed. For change details, review the revision history included in any revised document.

12.3 Community Resources

The following links connect to TI community resources. Linked contents are provided "AS IS" by the respective contributors. They do not constitute TI specifications and do not necessarily reflect TI's views; see TI's [Terms of Use](#).

TI E2E™ Online Community *TI's Engineer-to-Engineer (E2E) Community*. Created to foster collaboration among engineers. At e2e.ti.com, you can ask questions, share knowledge, explore ideas and help solve problems with fellow engineers.

Design Support *TI's Design Support* Quickly find helpful E2E forums along with design support tools and contact information for technical support.

12.4 Trademarks

E2E is a trademark of Texas Instruments.

12.5 Electrostatic Discharge Caution



This integrated circuit can be damaged by ESD. Texas Instruments recommends that all integrated circuits be handled with appropriate precautions. Failure to observe proper handling and installation procedures can cause damage.

ESD damage can range from subtle performance degradation to complete device failure. Precision integrated circuits may be more susceptible to damage because very small parametric changes could cause the device not to meet its published specifications.

12.6 Glossary

[SLYZ022](#) — *TI Glossary*.

This glossary lists and explains terms, acronyms, and definitions.

13 Mechanical, Packaging, and Orderable Information

The following pages include mechanical, packaging, and orderable information. This information is the most current data available for the designated devices. This data is subject to change without notice and revision of this document. For browser-based versions of this data sheet, refer to the left-hand navigation.

PACKAGING INFORMATION

Orderable Device	Status (1)	Package Type	Package Drawing	Pins	Package Qty	Eco Plan (2)	Lead/Ball Finish (6)	MSL Peak Temp (3)	Op Temp (°C)	Device Marking (4/5)	Samples
SN74AXC1T45DBVR	ACTIVE	SOT-23	DBV	6	3000	Green (RoHS & no Sb/Br)	CU NIPDAU	Level-1-260C-UNLIM	-40 to 125	1GRL	Samples
SN74AXC1T45DCKR	ACTIVE	SC70	DCK	6	3000	Green (RoHS & no Sb/Br)	CU SN	Level-1-260C-UNLIM	-40 to 125	1A3	Samples
SN74AXC1T45DEAR	ACTIVE	X2SON	DEA	6	5000	Green (RoHS & no Sb/Br)	CU NIPDAU	Level-1-260C-UNLIM	-40 to 125	CR	Samples
SN74AXC1T45DRLR	ACTIVE	SOT-5X3	DRL	6	4000	Green (RoHS & no Sb/Br)	CU NIPDAUAG	Level-1-260C-UNLIM	-40 to 125	1A1	Samples
SN74AXC1T45DTQR	ACTIVE	X2SON	DTQ	6	3000	Green (RoHS & no Sb/Br)	CU NIPDAU	Level-1-260C-UNLIM	-40 to 125	CW	Samples

(1) The marketing status values are defined as follows:

ACTIVE: Product device recommended for new designs.

LIFEBUY: TI has announced that the device will be discontinued, and a lifetime-buy period is in effect.

NRND: Not recommended for new designs. Device is in production to support existing customers, but TI does not recommend using this part in a new design.

PREVIEW: Device has been announced but is not in production. Samples may or may not be available.

OBSOLETE: TI has discontinued the production of the device.

(2) **RoHS:** TI defines "RoHS" to mean semiconductor products that are compliant with the current EU RoHS requirements for all 10 RoHS substances, including the requirement that RoHS substance do not exceed 0.1% by weight in homogeneous materials. Where designed to be soldered at high temperatures, "RoHS" products are suitable for use in specified lead-free processes. TI may reference these types of products as "Pb-Free".

RoHS Exempt: TI defines "RoHS Exempt" to mean products that contain lead but are compliant with EU RoHS pursuant to a specific EU RoHS exemption.

Green: TI defines "Green" to mean the content of Chlorine (Cl) and Bromine (Br) based flame retardants meet JS709B low halogen requirements of <=1000ppm threshold. Antimony trioxide based flame retardants must also meet the <=1000ppm threshold requirement.

(3) MSL, Peak Temp. - The Moisture Sensitivity Level rating according to the JEDEC industry standard classifications, and peak solder temperature.

(4) There may be additional marking, which relates to the logo, the lot trace code information, or the environmental category on the device.

(5) Multiple Device Markings will be inside parentheses. Only one Device Marking contained in parentheses and separated by a "-" will appear on a device. If a line is indented then it is a continuation of the previous line and the two combined represent the entire Device Marking for that device.

(6) Lead/Ball Finish - Orderable Devices may have multiple material finish options. Finish options are separated by a vertical ruled line. Lead/Ball Finish values may wrap to two lines if the finish value exceeds the maximum column width.

Important Information and Disclaimer: The information provided on this page represents TI's knowledge and belief as of the date that it is provided. TI bases its knowledge and belief on information provided by third parties, and makes no representation or warranty as to the accuracy of such information. Efforts are underway to better integrate information from third parties. TI has taken and continues to take reasonable steps to provide representative and accurate information but may not have conducted destructive testing or chemical analysis on incoming materials and chemicals. TI and TI suppliers consider certain information to be proprietary, and thus CAS numbers and other limited information may not be available for release.

In no event shall TI's liability arising out of such information exceed the total purchase price of the TI part(s) at issue in this document sold by TI to Customer on an annual basis.

OTHER QUALIFIED VERSIONS OF SN74AXC1T45 :

- Automotive: [SN74AXC1T45-Q1](#)

NOTE: Qualified Version Definitions:

- Automotive - Q100 devices qualified for high-reliability automotive applications targeting zero defects

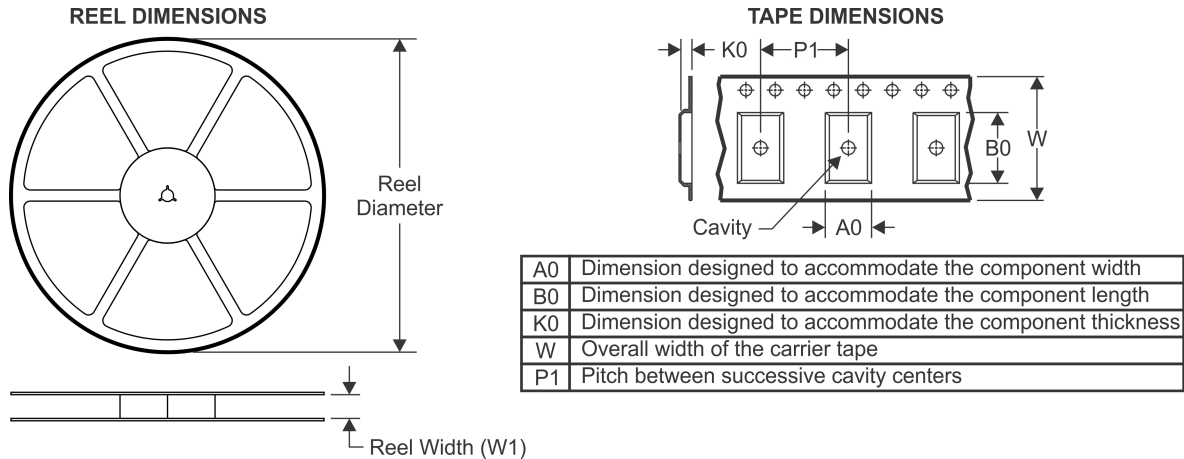
TAPE AND REEL INFORMATION

QUADRANT ASSIGNMENTS FOR PIN 1 ORIENTATION IN TAPE

*All dimensions are nominal

Device	Package Type	Package Drawing	Pins	SPQ	Reel Diameter (mm)	Reel Width W1 (mm)	A0 (mm)	B0 (mm)	K0 (mm)	P1 (mm)	W (mm)	Pin1 Quadrant
SN74AXC1T45DBVR	SOT-23	DBV	6	3000	180.0	8.4	3.2	3.2	1.4	4.0	8.0	Q3
SN74AXC1T45DCKR	SC70	DCK	6	3000	178.0	9.0	2.4	2.5	1.2	4.0	8.0	Q3
SN74AXC1T45DEAR	X2SON	DEA	6	5000	180.0	9.5	1.13	1.13	0.5	4.0	8.0	Q3
SN74AXC1T45DRLR	SOT-5X3	DRL	6	4000	180.0	8.4	1.98	1.78	0.69	4.0	8.0	Q3
SN74AXC1T45DTQR	X2SON	DTQ	6	3000	180.0	9.5	0.94	1.13	0.5	2.0	8.0	Q2

TAPE AND REEL BOX DIMENSIONS

*All dimensions are nominal

Device	Package Type	Package Drawing	Pins	SPQ	Length (mm)	Width (mm)	Height (mm)
SN74AXC1T45DBVR	SOT-23	DBV	6	3000	210.0	185.0	35.0
SN74AXC1T45DCKR	SC70	DCK	6	3000	180.0	180.0	18.0
SN74AXC1T45DEAR	X2SON	DEA	6	5000	189.0	185.0	36.0
SN74AXC1T45DRLR	SOT-5X3	DRL	6	4000	183.0	183.0	20.0
SN74AXC1T45DTQR	X2SON	DTQ	6	3000	189.0	185.0	36.0

DBV0006A



PACKAGE OUTLINE

SOT-23 - 1.45 mm max height

SMALL OUTLINE TRANSISTOR

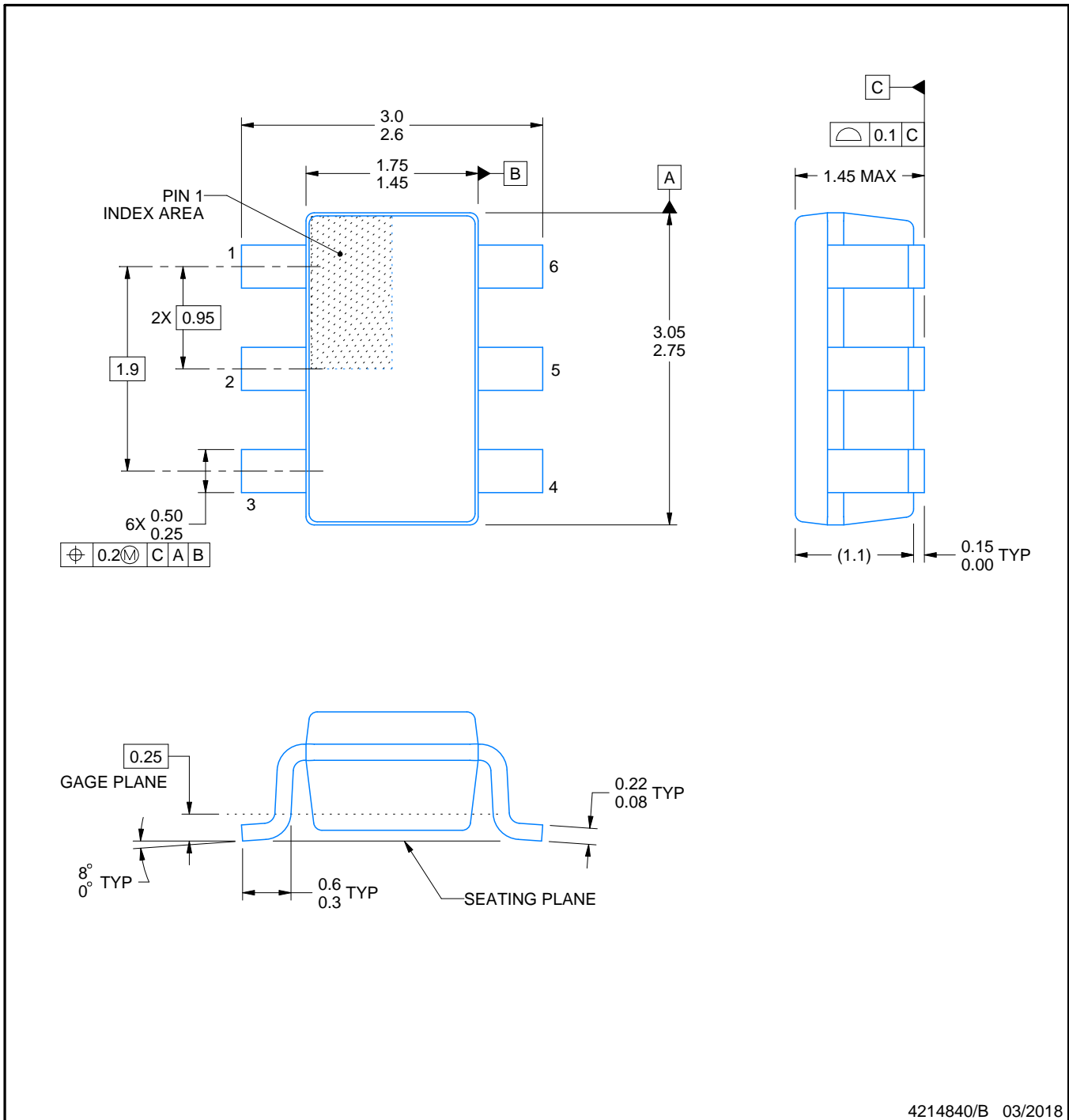

4214840/B 03/2018

NOTES:

1. All linear dimensions are in millimeters. Any dimensions in parenthesis are for reference only. Dimensioning and tolerancing per ASME Y14.5M.
2. This drawing is subject to change without notice.
3. Body dimensions do not include mold flash or protrusion. Mold flash and protrusion shall not exceed 0.15 per side.
4. Leads 1,2,3 may be wider than leads 4,5,6 for package orientation.
5. Reference JEDEC MO-178.

EXAMPLE BOARD LAYOUT

DBV0006A

SOT-23 - 1.45 mm max height

SMALL OUTLINE TRANSISTOR



LAND PATTERN EXAMPLE
EXPOSED METAL SHOWN
SCALE:15X



SOLDER MASK DETAILS

4214840/B 03/2018

NOTES: (continued)

- 6. Publication IPC-7351 may have alternate designs.
- 7. Solder mask tolerances between and around signal pads can vary based on board fabrication site.

EXAMPLE STENCIL DESIGN

DBV0006A

SOT-23 - 1.45 mm max height

SMALL OUTLINE TRANSISTOR



SOLDER PASTE EXAMPLE
BASED ON 0.125 mm THICK STENCIL
SCALE:15X

4214840/B 03/2018

NOTES: (continued)

8. Laser cutting apertures with trapezoidal walls and rounded corners may offer better paste release. IPC-7525 may have alternate design recommendations.
9. Board assembly site may have different recommendations for stencil design.

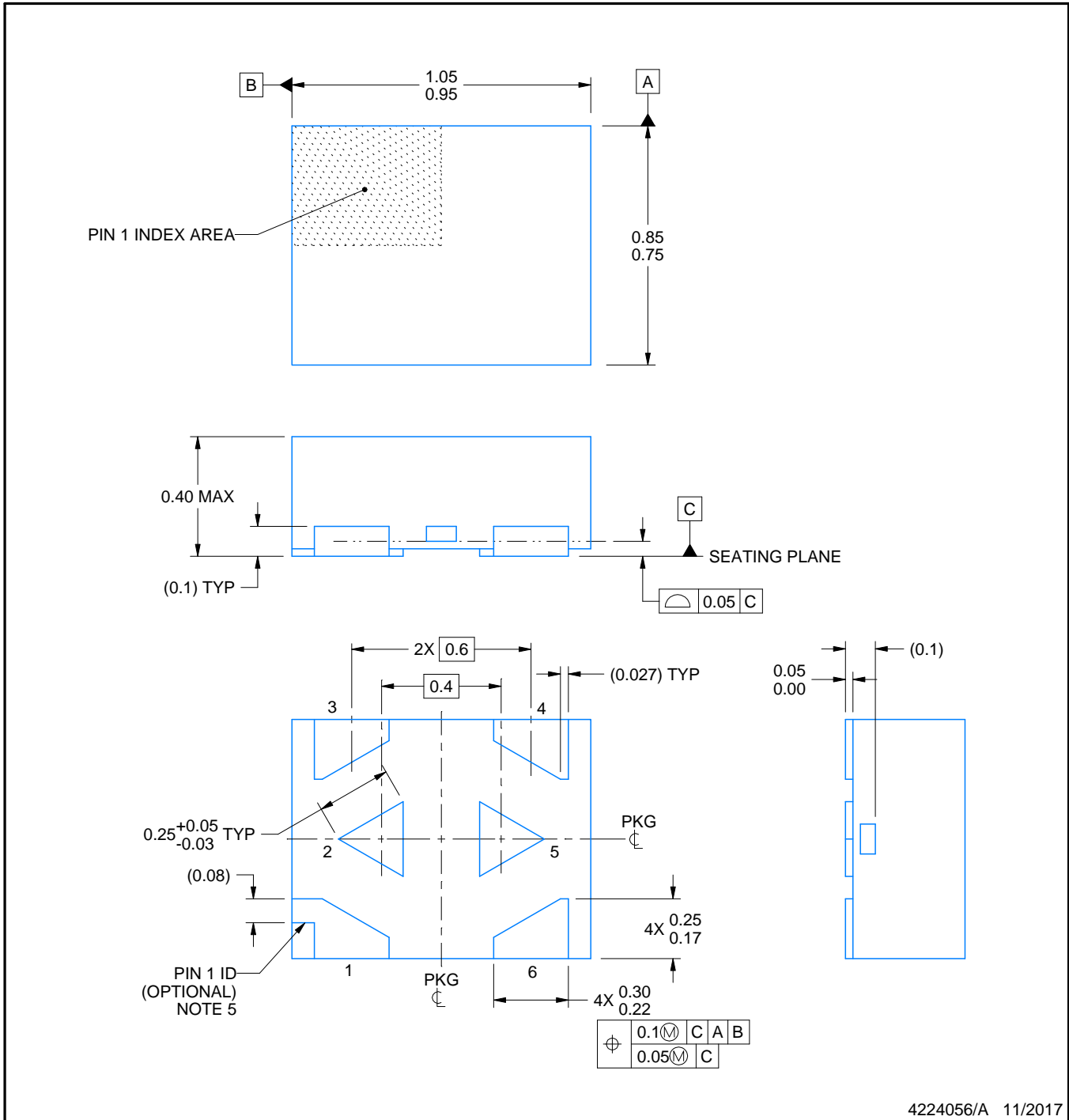

NOTES:

1. All linear dimensions are in millimeters. Any dimensions in parenthesis are for reference only. Dimensioning and tolerancing per ASME Y14.5M.
2. This drawing is subject to change without notice.
3. The package thermal pads must be soldered to the printed circuit board for optimal thermal and mechanical performance.
4. The size and shape of this feature may vary.
5. Features may not exist. Recommend use of pin 1 marking on top of package for orientation purposes.

EXAMPLE BOARD LAYOUT

DTQ0006A

X2SON - 0.4 mm max height

PLASTIC SMALL OUTLINE - NO LEAD

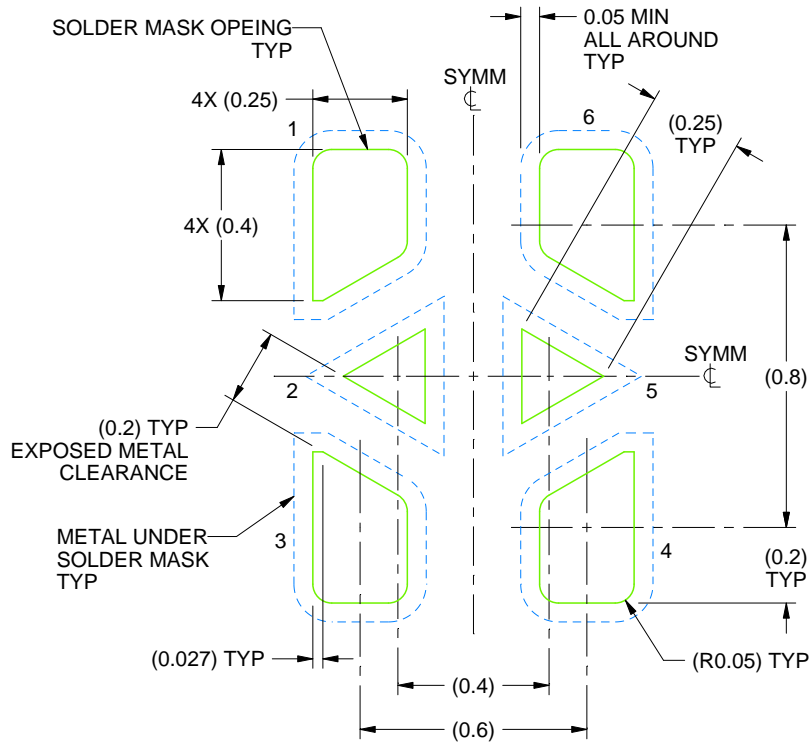

LAND PATTERN EXAMPLE
SOLDER MASK DEFINED
SCALE:50X

4224056/A 11/2017

NOTES: (continued)

6. This package is designed to be soldered to a thermal pads on the board. For more information, see Texas Instruments literature number SLUA271 (www.ti.com/lit/slua271).
7. Vias are optional depending on application, refer to device data sheet. If some or all are implemented, recommended via locations are shown.

EXAMPLE STENCIL DESIGN

DTQ0006A

X2SON - 0.4 mm max height

PLASTIC SMALL OUTLINE - NO LEAD

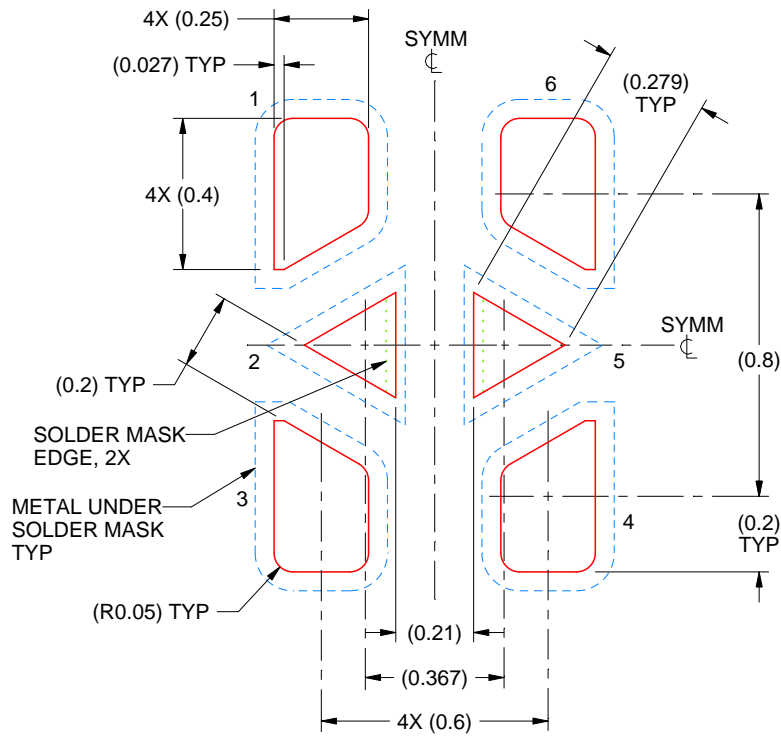

SOLDER PASTE EXAMPLE
BASED ON 0.07 mm THICK STENCIL

PRINTED SOLDER COVERAGE BY AREA UNDER PACKAGE
SCALE:50X

4224056/A 11/2017

NOTES: (continued)

8. Laser cutting apertures with trapezoidal walls and rounded corners may offer better paste release. IPC-7525 may have alternate design recommendations.

DCK (R-PDSO-G6)

PLASTIC SMALL OUTLINE

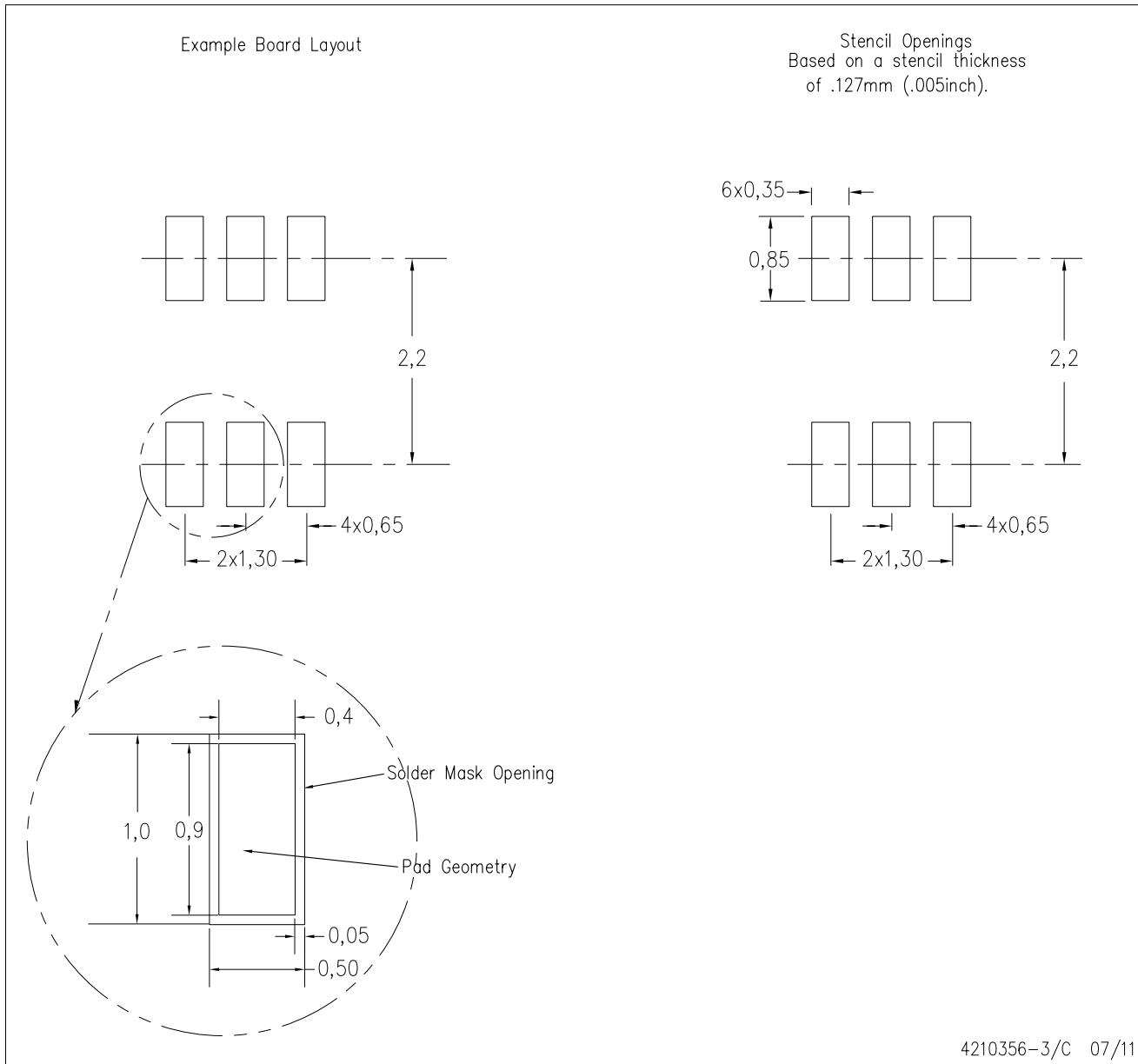

- NOTES:
- A. All linear dimensions are in millimeters.
 - B. This drawing is subject to change without notice.
 - C. Customers should place a note on the circuit board fabrication drawing not to alter the center solder mask defined pad.
 - D. Publication IPC-7351 is recommended for alternate designs.
 - E. Laser cutting apertures with trapezoidal walls and also rounding corners will offer better paste release. Customers should contact their board assembly site for stencil design recommendations. Example stencil design based on a 50% volumetric metal load solder paste. Refer to IPC-7525 for other stencil recommendations.

EXAMPLE BOARD LAYOUT

DRL0006A

SOT - 0.6 mm max height

PLASTIC SMALL OUTLINE

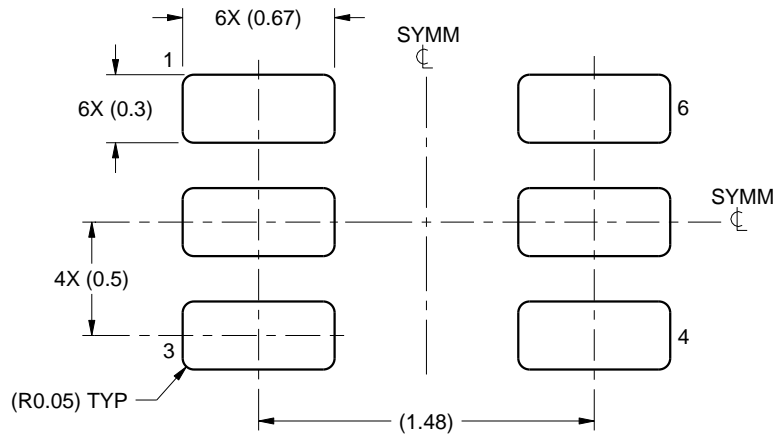

LAND PATTERN EXAMPLE
SCALE:30X

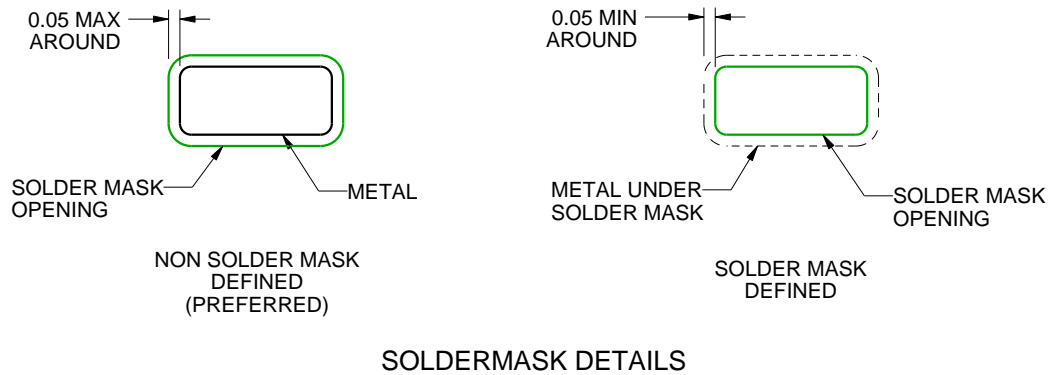

SOLDERMASK DETAILS

4223266/A 09/2016

NOTES: (continued)

- 4. Publication IPC-7351 may have alternate designs.
- 5. Solder mask tolerances between and around signal pads can vary based on board fabrication site.

EXAMPLE STENCIL DESIGN

DRL0006A

SOT - 0.6 mm max height

PLASTIC SMALL OUTLINE

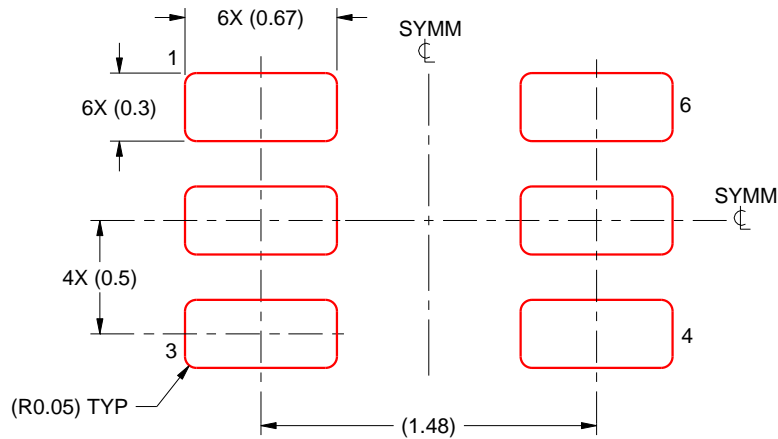

SOLDER PASTE EXAMPLE
BASED ON 0.1 mm THICK STENCIL
SCALE:30X

4223266/A 09/2016

NOTES: (continued)

6. Laser cutting apertures with trapezoidal walls and rounded corners may offer better paste release. IPC-7525 may have alternate design recommendations.
7. Board assembly site may have different recommendations for stencil design.

EXAMPLE BOARD LAYOUT

DEA0006A

X2SON - 0.4 mm max height

PLASTIC SMALL OUTLINE - NO LEAD

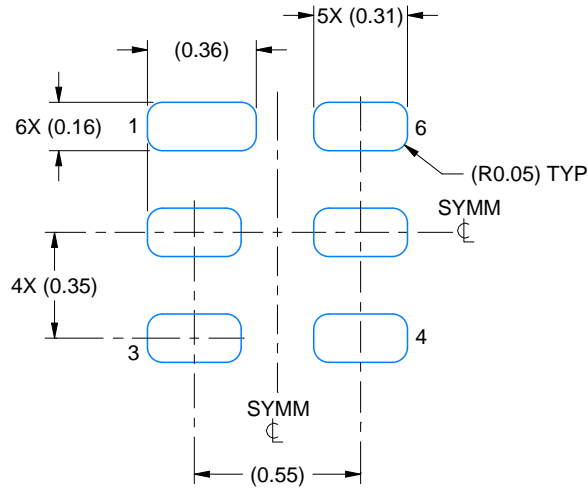

LAND PATTERN EXAMPLE
EXPOSED METAL SHOWN
SCALE:40X

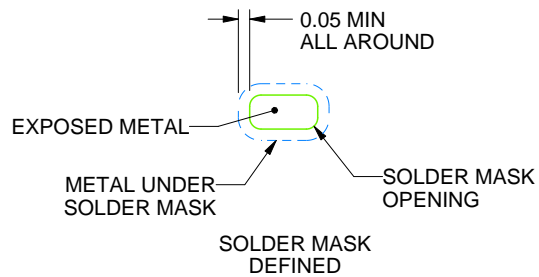

SOLDER MASK DETAILS

4223910/C 12/2017

NOTES: (continued)

3. For more information, see Texas Instruments literature number SLUA271 (www.ti.com/lit/slua271).

EXAMPLE STENCIL DESIGN

DEA0006A

X2SON - 0.4 mm max height

PLASTIC SMALL OUTLINE - NO LEAD

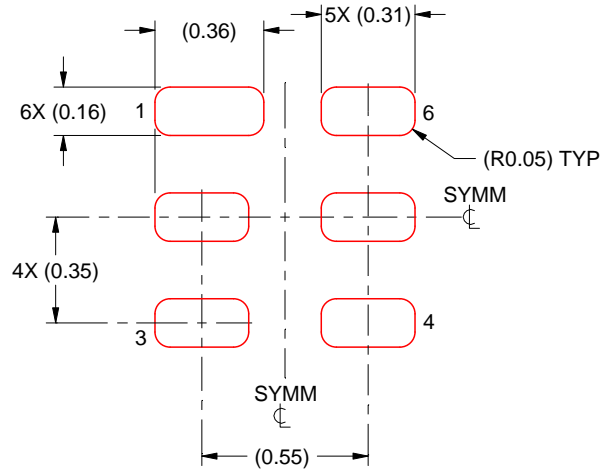

SOLDER PASTE EXAMPLE
BASED ON 0.075 mm THICK STENCIL
SCALE:40X

4223910/C 12/2017

4. Laser cutting apertures with trapezoidal walls and rounded corners may offer better paste release. IPC-7525 may have alternate design recommendations.

IMPORTANT NOTICE AND DISCLAIMER

TI PROVIDES TECHNICAL AND RELIABILITY DATA (INCLUDING DATASHEETS), DESIGN RESOURCES (INCLUDING REFERENCE DESIGNS), APPLICATION OR OTHER DESIGN ADVICE, WEB TOOLS, SAFETY INFORMATION, AND OTHER RESOURCES "AS IS" AND WITH ALL FAULTS, AND DISCLAIMS ALL WARRANTIES, EXPRESS AND IMPLIED, INCLUDING WITHOUT LIMITATION ANY IMPLIED WARRANTIES OF MERCHANTABILITY, FITNESS FOR A PARTICULAR PURPOSE OR NON-INFRINGEMENT OF THIRD PARTY INTELLECTUAL PROPERTY RIGHTS.

These resources are intended for skilled developers designing with TI products. You are solely responsible for (1) selecting the appropriate TI products for your application, (2) designing, validating and testing your application, and (3) ensuring your application meets applicable standards, and any other safety, security, or other requirements. These resources are subject to change without notice. TI grants you permission to use these resources only for development of an application that uses the TI products described in the resource. Other reproduction and display of these resources is prohibited. No license is granted to any other TI intellectual property right or to any third party intellectual property right. TI disclaims responsibility for, and you will fully indemnify TI and its representatives against, any claims, damages, costs, losses, and liabilities arising out of your use of these resources.

TI's products are provided subject to TI's Terms of Sale (www.ti.com/legal/termsofsale.html) or other applicable terms available either on ti.com or provided in conjunction with such TI products. TI's provision of these resources does not expand or otherwise alter TI's applicable warranties or warranty disclaimers for TI products.

Mailing Address: Texas Instruments, Post Office Box 655303, Dallas, Texas 75265
Copyright © 2019, Texas Instruments Incorporated