

36V Low Power Single Differential Comparators

Features

- Supply Operation From 2.5 V to 36 V
- Response time: 1.3 μ s(typ) at $V_{CC}=5V$
- Low Current Consumption: 218 μ A
- Low Input Bias Current: 130pA
- Low Input Offset Voltage: ± 0.6 mV
- Input Common-mode Voltage Range Includes Ground
- Internal Differential Input Voltage Range Equal to the Supply Voltage
- TTL, DTL, ECL, MOS, CMOS compatible Outputs
- Open drain output
- Wide Temperature Range: -40 $^{\circ}$ C to 125 $^{\circ}$ C
- High ESD Tolerance: 6 kV HBM, 2 kV CDM

Applications

- Peak and Zero-crossing Detectors
- Threshold Detectors/Discriminators
- Sensing at Ground or Supply Line
- High-speed Line or Digital Line Receivers
- High Speed Sampling Circuits

Typical Application Circuit

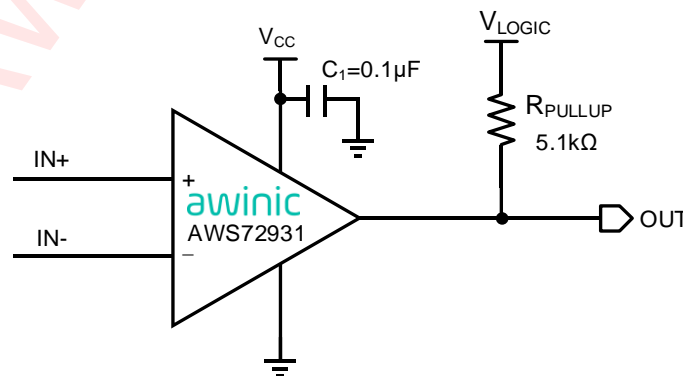

Figure 1 Typical Application of AWS72931

General Description

The AWS72931 consist of one independent voltage comparator that is designed to operate from a single power supply over a wide range of voltages. The device is the most cost-effective solutions for applications where low offset voltage, high supply voltage capability, low supply current, and space saving are the primary specifications in circuit design for portable consumer products.

The AWS72931 is available in green small-size SOT23 - 5L package.

Device Information

PART NUMBER	PACKAGE	BODY SIZE (NOM)
AWS72931	SOT23 - 5L	1.6mm \times 2.92mm

Pin Configuration And Top Mark

SOT23 - 5L

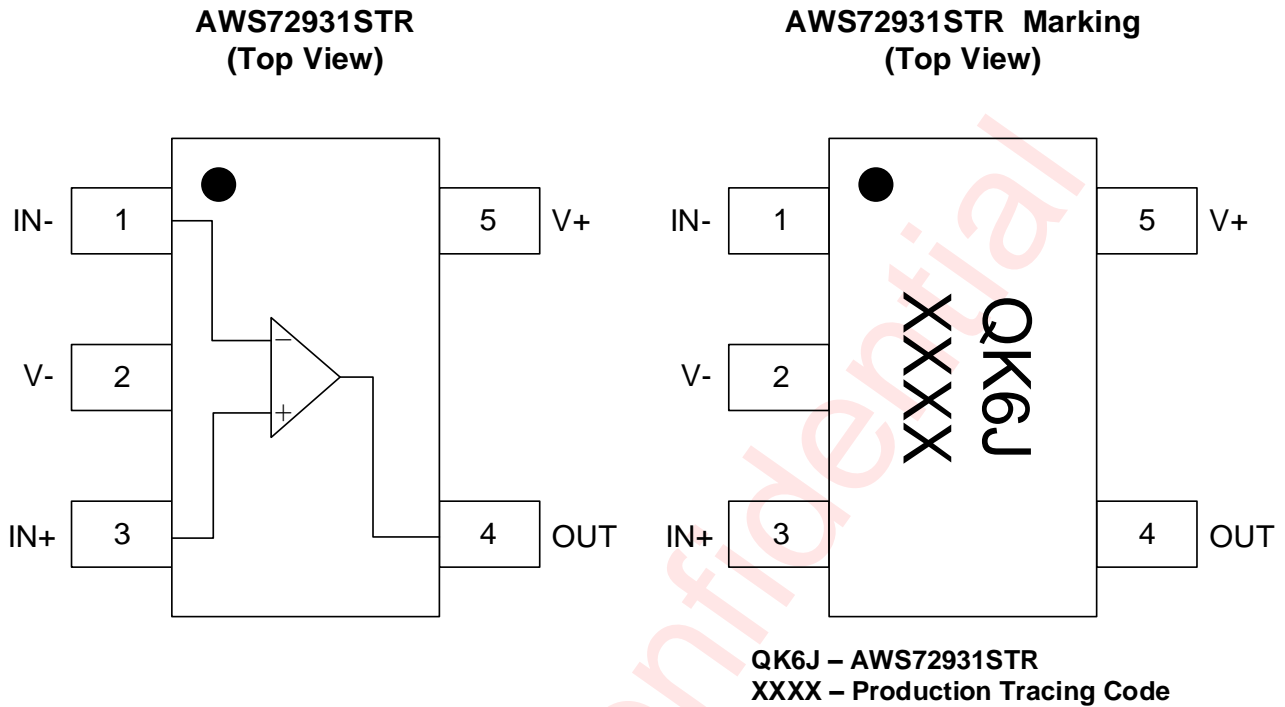

Figure 2 Pin Configuration

Pin Definition

PIN		DESCRIPTION
NAME	SOT23 – 5L STR	
IN-	1	Inverting input
V-	2	Negative (low) supply or ground (for single-supply operation)
IN+	3	Noninverting input
OUT	4	Output
V+	5	Positive (high) supply

Functional Block Diagram

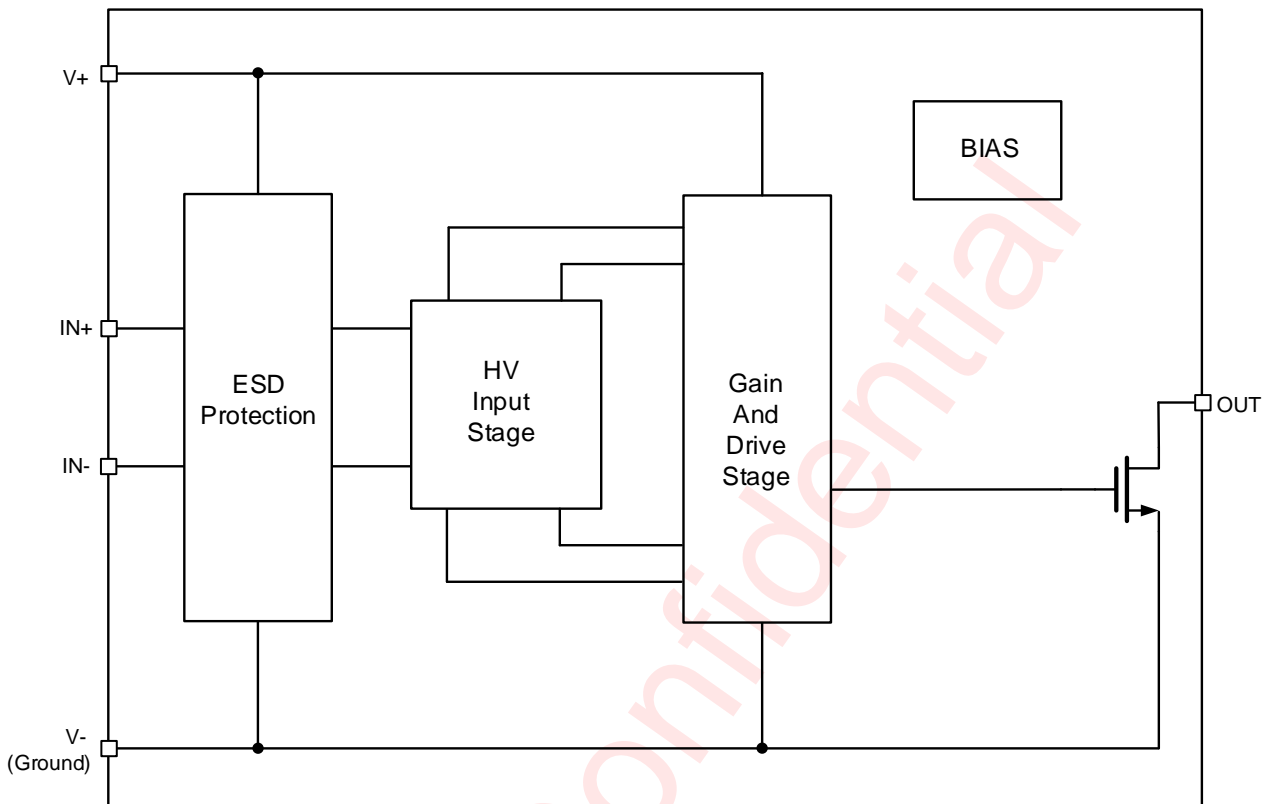

Figure 3 Functional Block Diagram

Typical Application Circuits

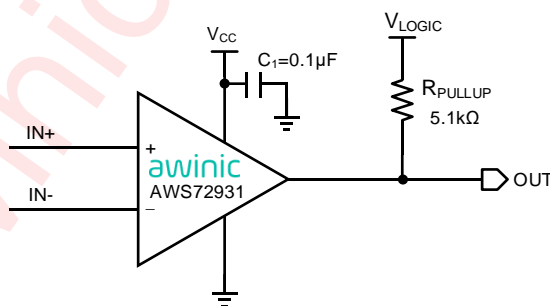

Figure 4 AWS72931 Application Circuit

Notice for typical application circuits:

1. Bypass capacitors C_1 is used to reduce the coupled noise by providing a low-impedance path to ground. So low-ESR, 0.1 μ F ceramic bypass capacitors are necessary between each supply pin and ground, placed close to the device, but far away from input traces. If negative supply is connected to GND, then negative supply to GND can be disconnected to bypass ceramic.

Ordering Information

Part Number	Temperature	Package	Marking	Moisture Sensitivity Level	Environmental Information	Delivery Form
AWS72931STR	-40°C ~ 125°C	SOT23 - 5L	QK6J	MSL3	RoHS+HF	3000 units/ Tape and Reel

Absolute Maximum Ratings (NOTE1)

PARAMETERS	RANGE
Supply voltage, $V_S = (V+) - (V-)$	42V
Input Voltage	(V-) - 0.3V to (V+) + 0.3V
Output Current: OUT	±20mA
Output short-circuit (NOTE 2)	Infinite
Operating free-air temperature range T_A	-40°C to 125°C
Maximum operating junction temperature T_{JMAX}	150°C
Storage temperature T_{STG}	-65°C to 150°C
Lead temperature (soldering 10 seconds)	260°C

NOTE1: Conditions out of those ranges listed in "absolute maximum ratings" may cause permanent damages to the device. In spite of the limits above, functional operation conditions of the device should be within the ranges listed in "recommended operating conditions". Exposure to absolute-maximum-rated conditions for prolonged periods may affect device reliability.

NOTE2: A heat sink may be required to keep the junction temperature below the absolute maximum. This depends on the power supply voltage and how many amplifiers are shorted. Thermal resistance varies with the amount of PC board metal connected to the package. The specified values are for short traces connected to the leads.

ESD Rating and Latch Up

PARAMETERS	VALUE	UNIT
HBM (Human Body Model) (NOTE 3)	±6	kV
CDM (NOTE 4)	±2	kV
Latch-Up (NOTE 5)	±150	mA

NOTE3: The human body model is a 100pF capacitor discharged through a 1.5kΩ resistor into each pin. Test method: ESDA/JEDEC JS-001-2023

NOTE4: Test method: ESDA/JEDEC JS-002-2022

NOTE5: Test method: JESD78F

Thermal Information

THERMAL METRICS		AWS72931	UNIT
		SOT23 – 5L	
SYMBOL	PARAMETER	5 PINS	
$R_{\theta JA}$	Junction-to-ambient thermal resistance	121.141	$^{\circ}\text{C/W}$
$R_{\theta JB}$	Junction-to-board thermal resistance	65.088	$^{\circ}\text{C/W}$
$R_{\theta JC}$	Junction-to-case (top) thermal resistance	73.757	$^{\circ}\text{C/W}$
Ψ_{JT}	Junction-to-top characterization parameter	18.6	$^{\circ}\text{C/W}$
Ψ_{JB}	Junction-to-board characterization parameter	64.991	$^{\circ}\text{C/W}$

Awinic Confidential

Electrical Characteristics

Electrical characteristics at $V_{CC} = 5\text{ V}$, $T_A = 25\text{ }^\circ\text{C}$, $V_{CM} = V_{CC}/2$, (unless otherwise specified).

SYMBOL	PARAMETER	TEST CONDITION	MIN	TYP	MAX	UNIT
V_{CC}	Supply Voltage		2.5		36	V
V_{OS}	Input offset voltage	$V_{CC} = 2.5\text{ to }36\text{ V}$	-3	± 0.6	3	mV
		$-40\text{ }^\circ\text{C} \sim 125\text{ }^\circ\text{C}$	-6		6	mV
I_{OS}	Input offset current			45		pA
I_B	Input bias current			130		pA
I_{Diff}	Input Differential Current			10		nA
C_{IN}	Input Capacitance	Differential ⁽¹⁾		2		pF
		Common Mode		3.5		pF
V_{CM}	Common-mode Input Voltage Range	$25\text{ }^\circ\text{C}$	0		$V_{CC}-1.5$	V
		$-40\text{ }^\circ\text{C} \sim 125\text{ }^\circ\text{C}$	0		$V_{CC}-2$	V
A_{VD}	Large-signal Differential Voltage Amplification	$V_{CC} = 15\text{ V}$, $V_O = 1.4\text{ V to }11.4\text{ V}$, $R_L \geq 15\text{ k}\Omega$ to V_{CC}	100	500		V/mV
I_{OH}	High-level Output Current	$V_{CC} = V_{OH} = 5\text{ V}$, $V_{ID} = 1\text{ V}$		3.7	200	nA
		$V_{CC} = V_{OH} = 36\text{ V}$, $V_{ID} = 1\text{ V}$, $-40\text{ }^\circ\text{C} \sim 125\text{ }^\circ\text{C}$		75	7000	nA
V_{OL}	Low-Level Output Voltage	$I_{OL} = 4\text{ mA}$, $V_{ID} = -1\text{ V}$		220	400	mV
I_{OL}	Low-Level Output Current	$V_{OL} = 1.5\text{ V}$, $V_{ID} = -1\text{ V}$	10	24		mA
I_Q	Quiescent Current	$V_{CC} = 5\text{ V}$		214	300	μA
		$V_{CC} = 36\text{ V}$		218	300	μA
t_{RT}	Response Time	R_L connected to 5 V through $5.1\text{ k}\Omega$, $C_L = 15\text{ pF}$	100-mV input step with 5-mV overdrive		1.3	μs
			TTL-level input step		0.16	μs

(1) The values are guaranteed by design.

Typical Characteristics

At $T_A = 25^\circ\text{C}$, $V_{CC} = 5\text{V}$, $V_{CM} = 0\text{V}$, $R_L = \text{Open}$, unless otherwise noted.

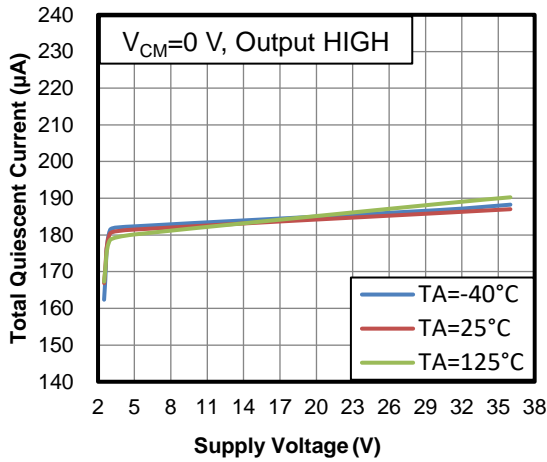

Figure 5 I_Q vs. V_{CC}

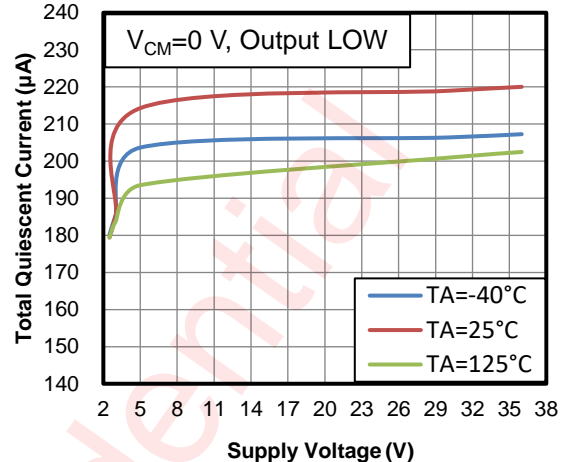

Figure 6 I_Q vs. V_{CC}

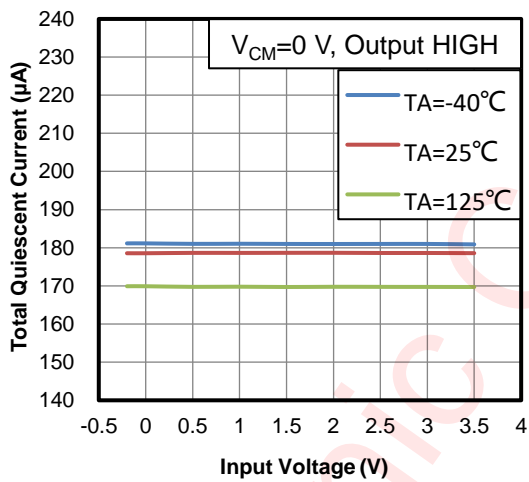

Figure 7 I_Q vs. V_{CM} at $V_{CC} = 5\text{V}$

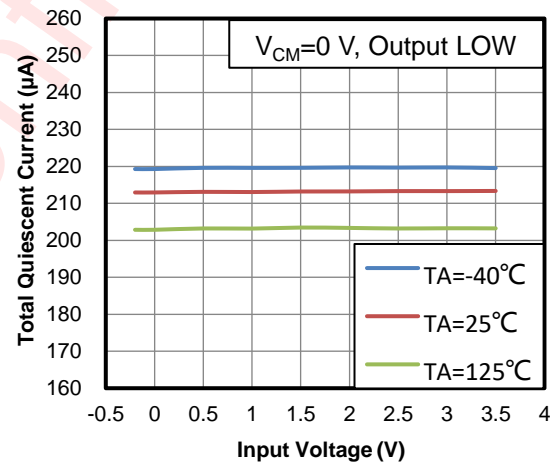

Figure 8 I_Q vs. V_{CM} at $V_{CC} = 5\text{V}$

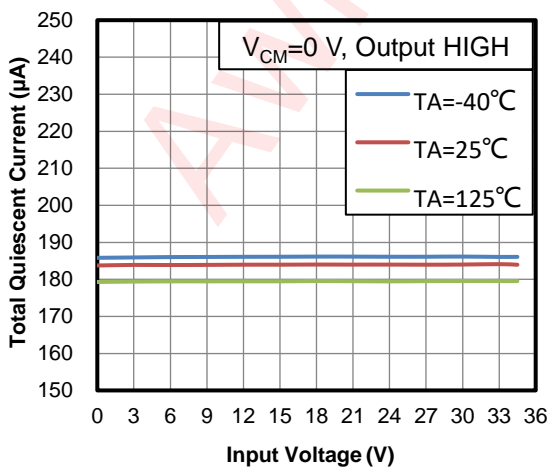

Figure 9 I_Q vs. V_{CM} at $V_{CC} = 36\text{V}$

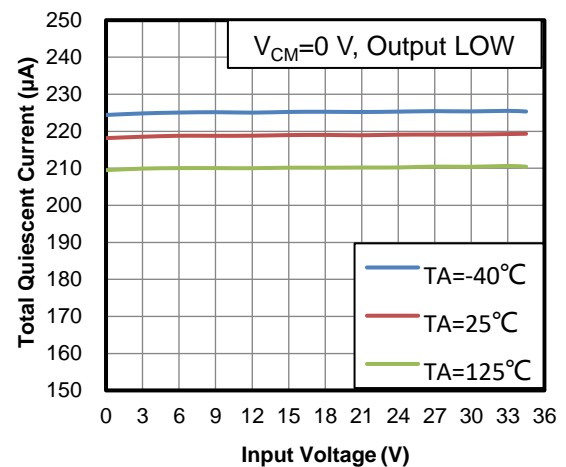

Figure 10 I_Q vs. V_{CM} at $V_{CC} = 36\text{V}$

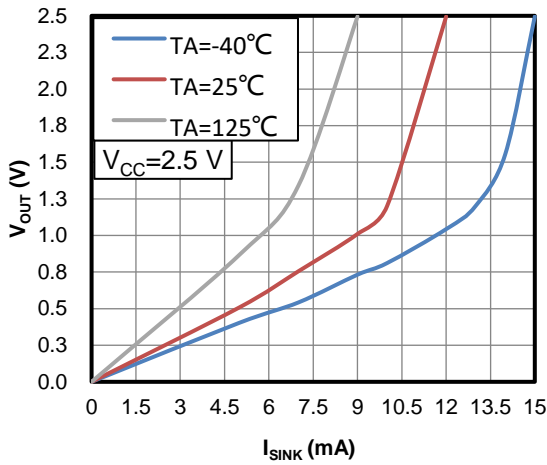

Figure 11 V_{OUT} vs. I_{SINK}

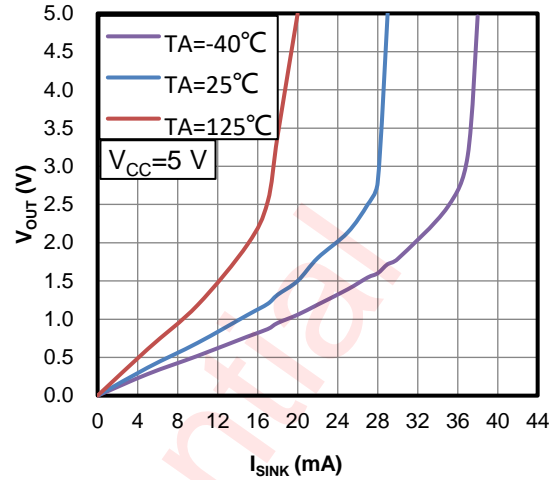

Figure 12 V_{OUT} vs. I_{SINK}

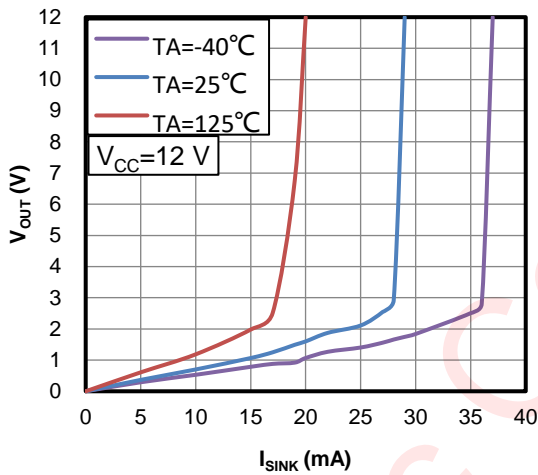

Figure 13 V_{OUT} vs. I_{SINK}

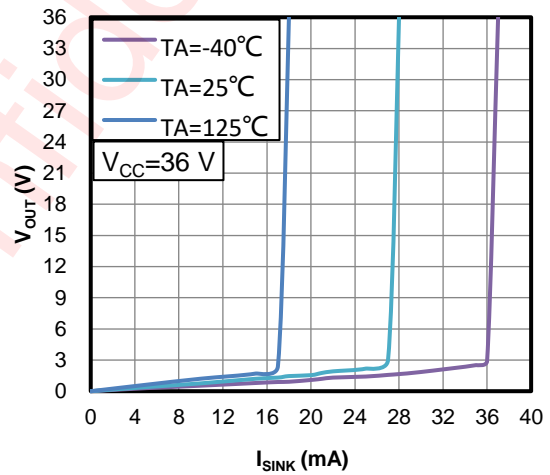

Figure 14 V_{OUT} vs. I_{SINK}

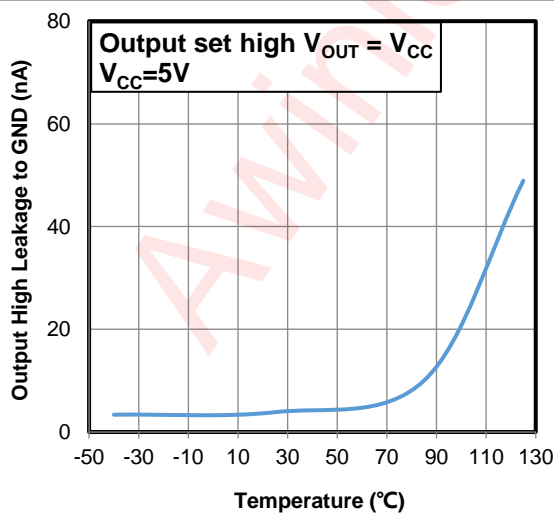

Figure 15 I_{OH} vs. Temperature

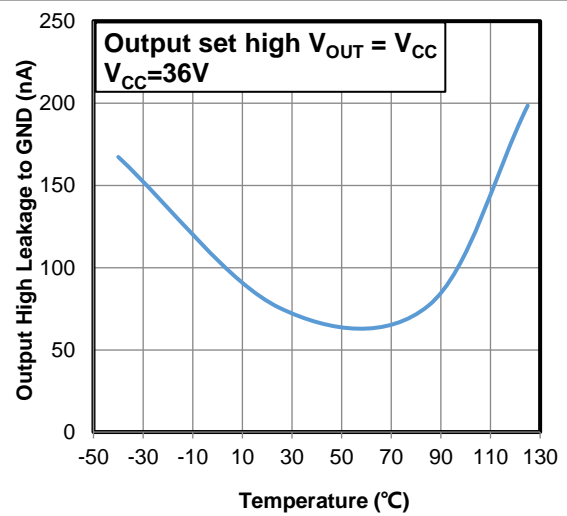

Figure 16 I_{OH} vs. Temperature

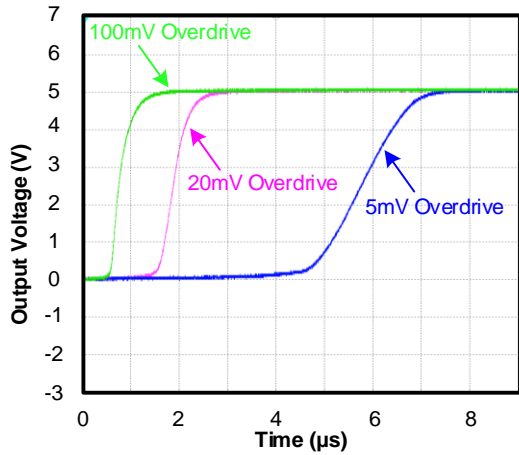

Figure 17 Response Time for Various Input Overdrives:
Positive Transition

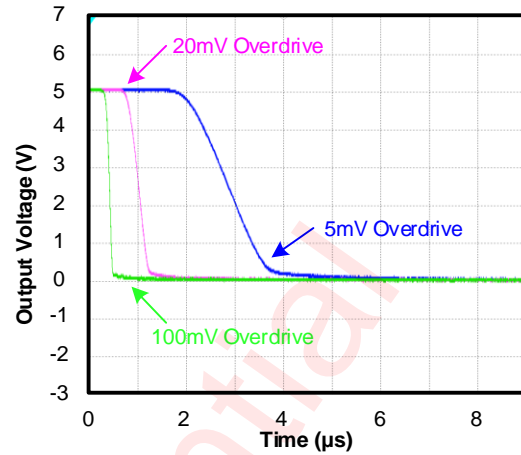

Figure 18 Response Time for Various Input Overdrives:
Negative Transition

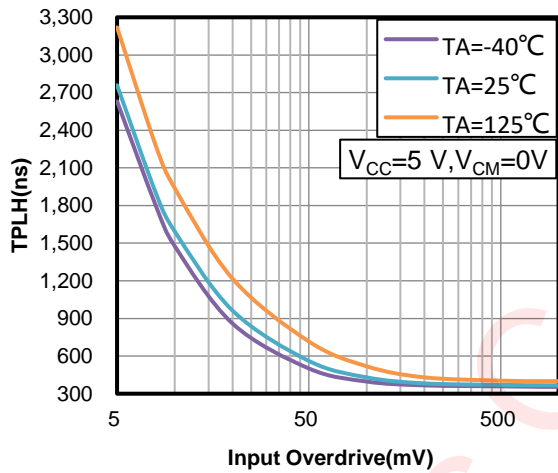

Figure 19 TPLH vs. Input Overdrive

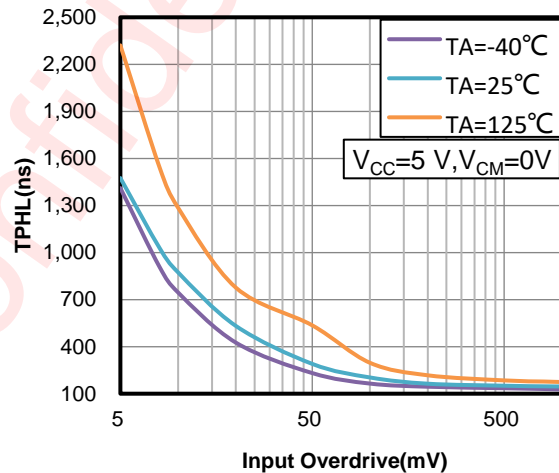

Figure 20 TPHL vs. Input Overdrive

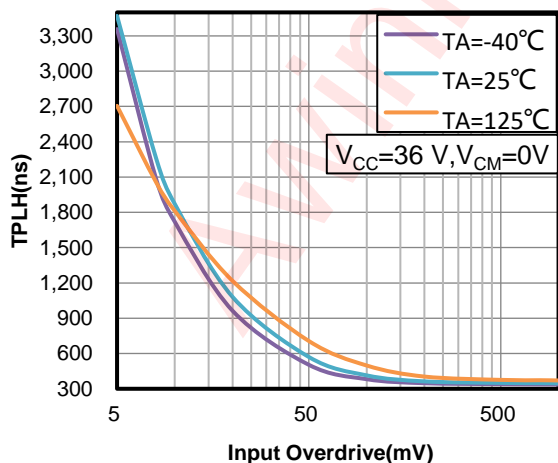

Figure 19 TPLH vs. Input Overdrive

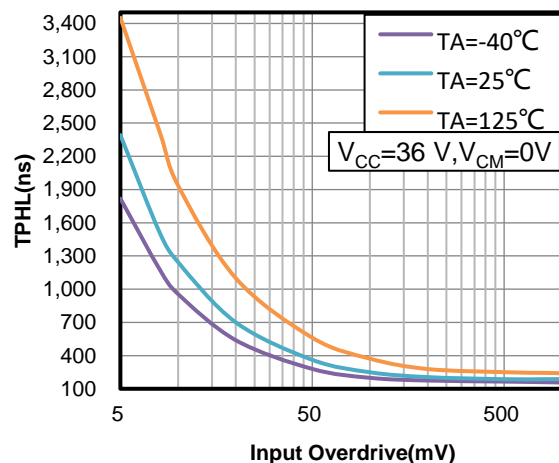

Figure 20 TPHL vs. Input Overdrive

Detailed Functional Description

This comparator has the ability to operate up to absolute maximum of 36 V on the supply pin. This device has proven ubiquity and versatility across a wide range of applications. This is due to very wide supply voltages range, low I_Q and fast response of the devices.

The open-drain output allows the user to configure the output's logic high voltage (V_{OH}) and can be used to enable the comparator to be used in AND functionality.

Voltage Comparison

The device operates solely as a voltage comparator, comparing the differential voltage between the positive and negative pins and outputting a logic low or high impedance (logic high with pullup) based on the input differential polarity.

Application Information

The device is typically used to compare a single signal to a reference or two signals against each other. Many users take advantage of the open drain output to drive the comparison logic output to a logic voltage level to an MCU or logic device. The wide supply range and high voltage capability makes this comparator optimal for level shifting to a higher or lower voltage.

Typical Application

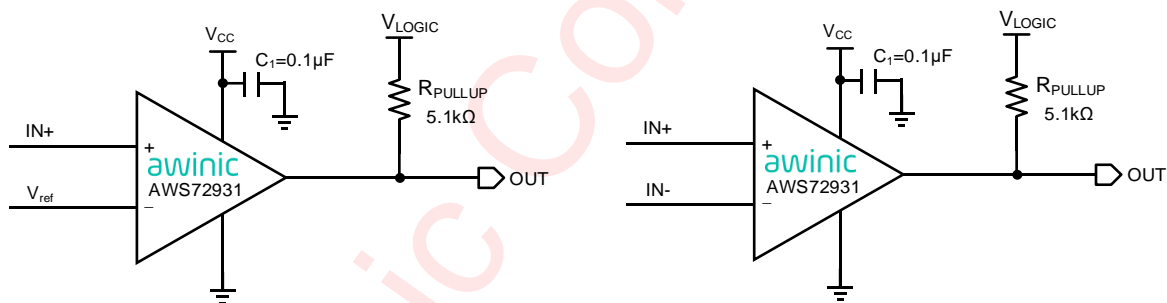

Figure 21 Single-Ended and Differential Comparator Configurations

Input Voltage Range

When choosing the input voltage range, the input common mode voltage range (V_{ICR}) must be taken in to account. If temperature operation is below 25°C the V_{ICR} can range from 0 V to $V_{CC} - 2.0$ V. This limits the input voltage range to as high as $V_{CC} - 2.0$ V and as low as 0 V. Operation outside of this range can yield incorrect comparisons.

Input signal range extends beyond the negative and positive power supplies. The output can even extend all the way to the negative supply. The input stage is active over different ranges of common mode input voltage. Rail-to-rail input voltage range and low voltage single-supply operation make these devices ideal for portable equipment.

Minimum Overdrive Voltage

Overdrive Voltage is the differential voltage produced between the positive and negative inputs of the comparator over the offset voltage (V_{IO}). To make an accurate comparison the Overdrive Voltage (V_{OD}) should

be higher than the input offset voltage (V_{IO}). Overdrive voltage can also determine the response time of the comparator, with the response time decreasing with increasing overdrive.

Output and Drive Current

Output current is determined by the load/pull-up resistance and logic/pullup voltage. The output current produces a output low voltage (V_{OL}) from the comparator. In which V_{OL} is proportional to the output current.

Response Time

Response time is a function of input over drive. The rise and falls times can be determined by the load capacitance (C_L), load/pullup resistance (R_{PULLUP}) and equivalent drain-source resistance (R_{DS}).

Awinic Confidential

PCB Layout Consideration

For the optimal performance of the device, good PCB layout practices are needed, here are some guidelines:

1. Bypass capacitors are used to reduce the coupled noise by providing a low-impedance path to ground. So low-ESR, 0.1 μF ceramic bypass capacitors are necessary between each supply pin and ground, placed close to the device, but far away from input traces.
2. Use a printed circuit board (PCB) with a good, unbroken low-inductance ground plane.
3. Solder the device directly to the PCB rather than using a socket.
4. Any precision integrated circuit may experience performance shifts due to moisture ingress into the plastic package. Following any aqueous PCB cleaning process, baking the PCB assembly is recommended to remove moisture introduced into the device packaging during the cleaning process.

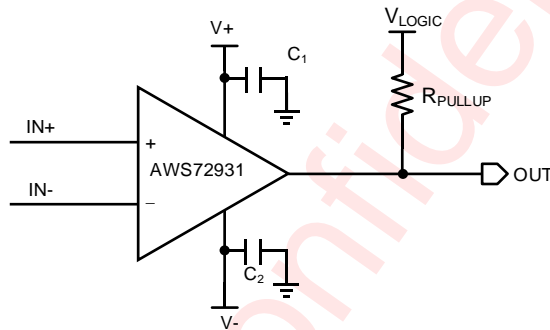

Figure 22 AWS72931 Schematic Example

SOT23 - 5L_AWS72931STR

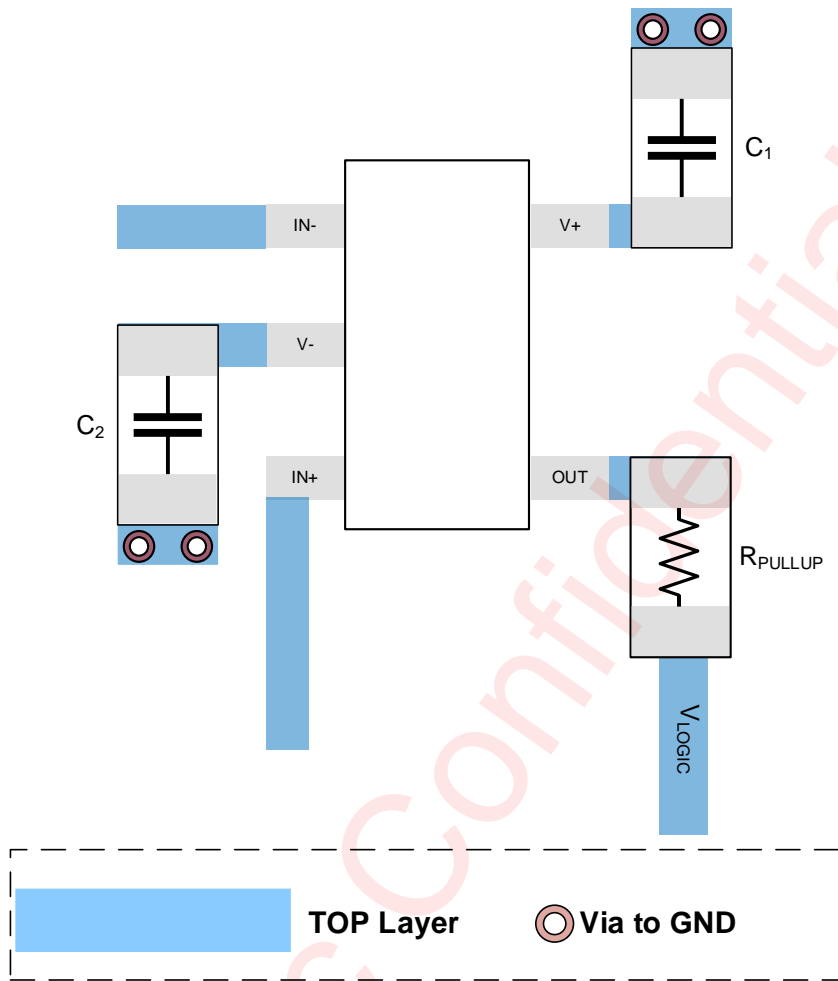

Figure 23 AWS72931 Layout Example

PCB Surface Leakage Current

In high precision applications where input bias current is critically concerned, the leakage current on PCB surface caused by dust or humidity may badly reduce the output accuracy. In this case, a multi-layer PCB is recommended for routing the input traces under the PCB surface. In addition, the usage of a guard ring can significantly reduce the leakage current to sensitive node. A conductive ring surrounding the inputs should be connected to a low impedance node with the same voltage as the inputs, so this ring will absorb the leakage current from high voltage nodes around the inputs.

For non-inverting Configuration, connect the IN+ to the input with traces not touching the PCB surface, for example, routing in second layer in Figure 24. Then surround the IN+ pin with a guard ring which is connected to IN-, thus biasing the guard ring with the same voltage of the common mode input voltage.

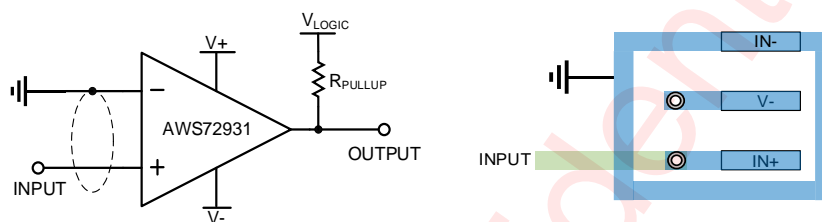

Figure 24 Non-inverting Comparator Application Schematic and Layout Example

Similarly, for inverting Configuration, connect the IN- to the input with traces not touching the PCB surface, for example, routing in second layer in Figure 25. Then surround the IN- pin with a guard ring which is connected to IN+, thus biasing the guard ring with the reference voltage of AWS72931.

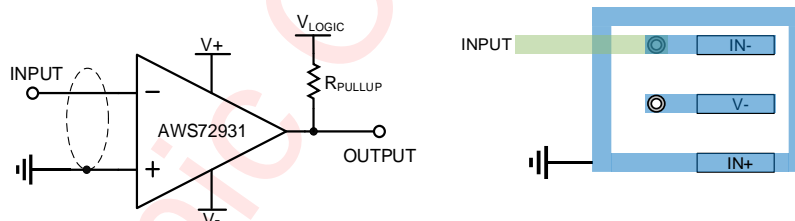
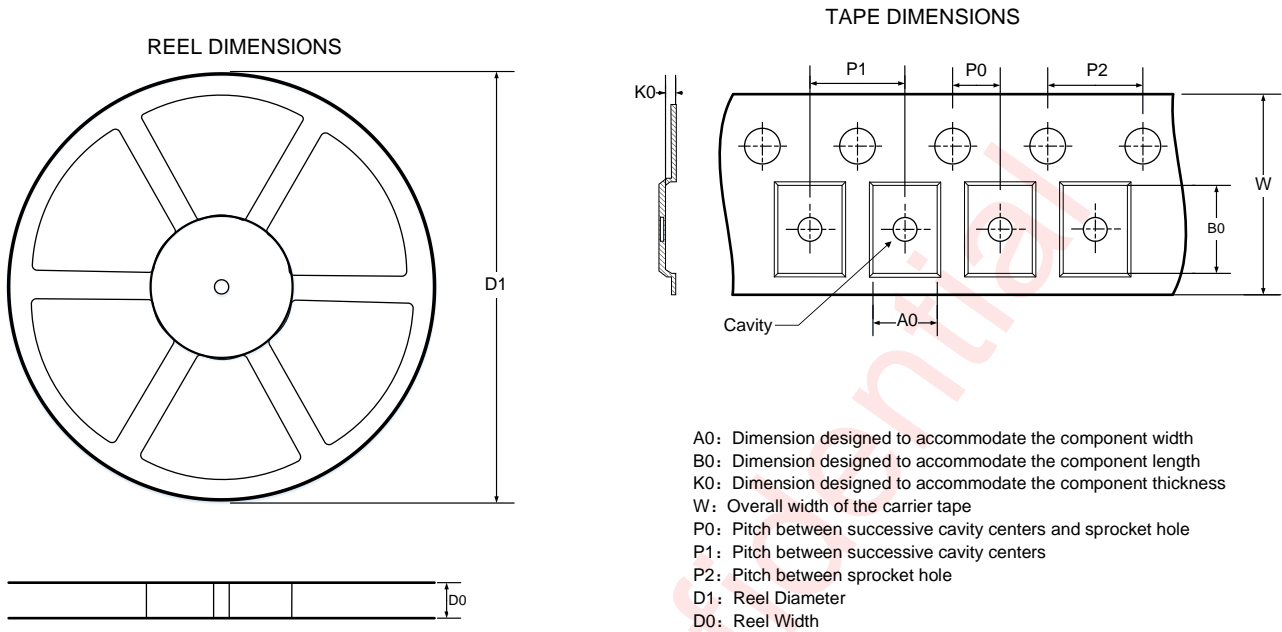
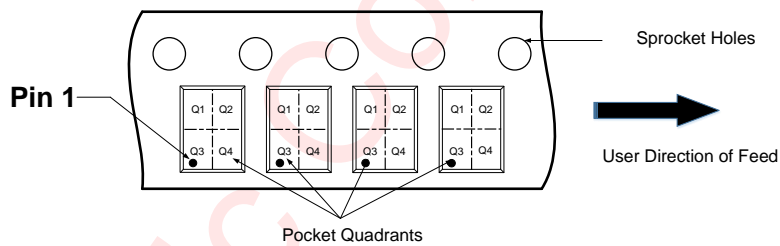

Figure 25 Inverting Comparator Application Schematic and Layout Example

Tape And Reel Information



QUADRANT ASSIGNMENTS FOR PIN 1 ORIENTATION IN TAPE



Note: The above picture is for reference only. Please refer to the value in the table below for the actual size

DIMENSIONS AND PIN1 ORIENTATION

D1 (mm)	D0 (mm)	A0 (mm)	B0 (mm)	K0 (mm)	P0 (mm)	P1 (mm)	P2 (mm)	W (mm)	Pin1 Quadrant
180.00	8.60	3.26	3.30	1.40	2.00	4.00	4.00	8.00	Q3

All dimensions are nominal

Package Description

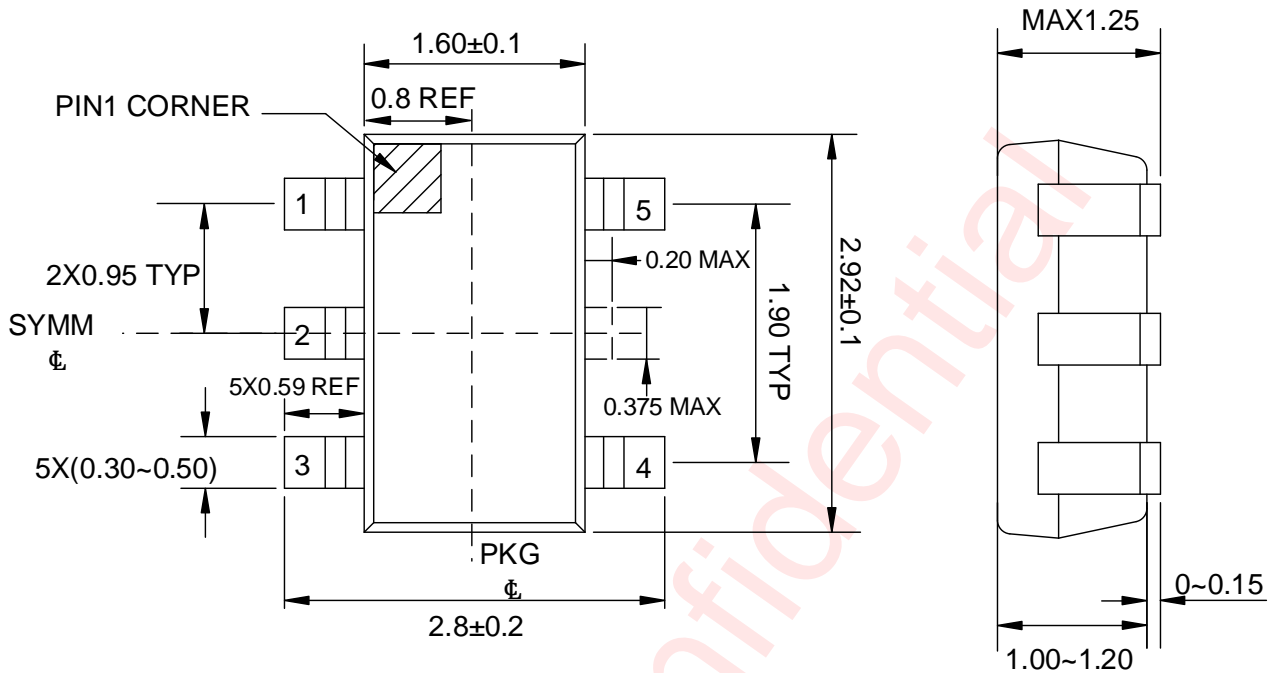

Top View

Side View

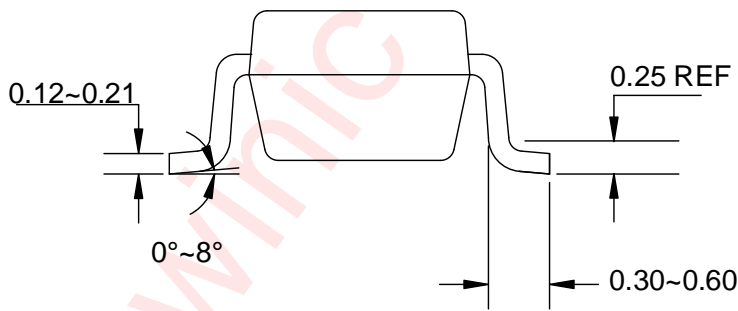

Side View

Unit: mm

Land Pattern Data

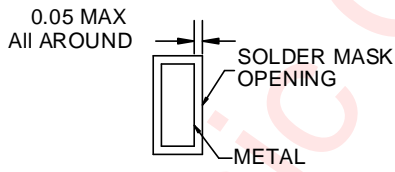
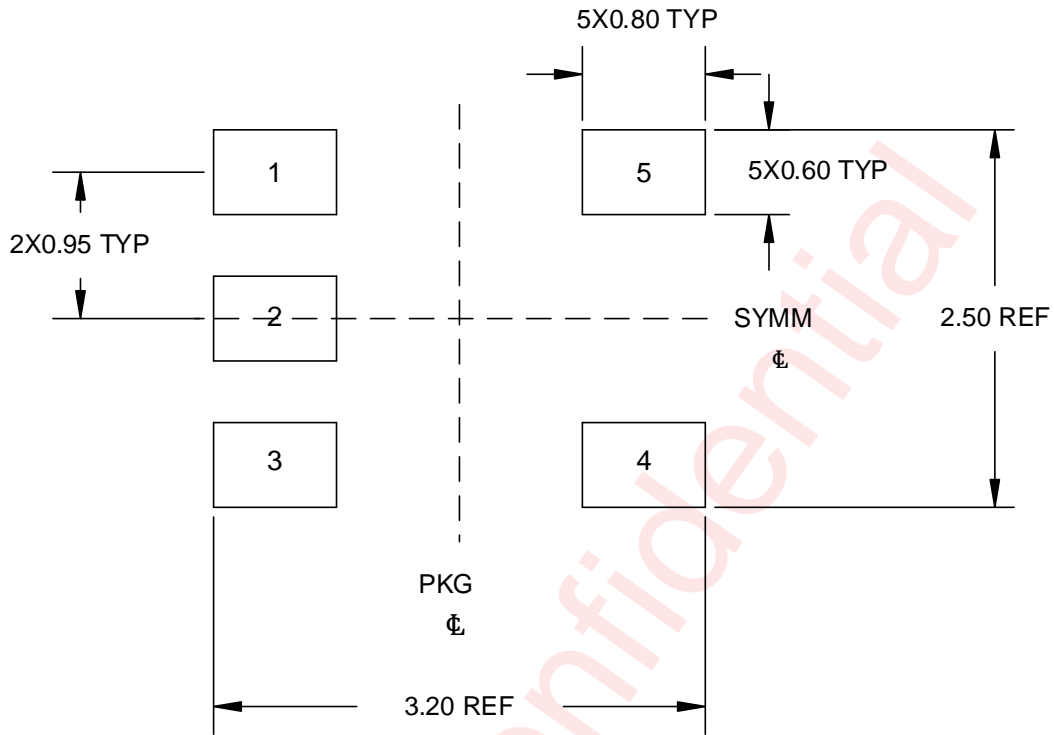

NON SOLDER MASK DEFINED

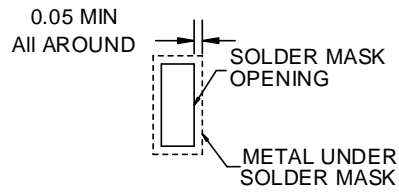

SOLDER MASK DEFINED

Unit: mm

Revision History

Version	Date	Change Record
V1.0	Apr. 2024	Official released

Awinic Confidential

Disclaimer

All trademarks are the property of their respective owners. Information in this document is believed to be accurate and reliable. However, Shanghai AWINIC Technology Co., Ltd (AWINIC Technology) does not give any representations or warranties, expressed or implied, as to the accuracy or completeness of such information and shall have no liability for the consequences of use of such information.

AWINIC Technology reserves the right to make changes to information published in this document, including without limitation specifications and product descriptions, at any time and without notice. Customers shall obtain the latest relevant information before placing orders and shall verify that such information is current and complete. This document supersedes and replaces all information supplied prior to the publication hereof.

AWINIC Technology products are not designed, authorized or warranted to be suitable for use in medical, military, aircraft, space or life support equipment, nor in applications where failure or malfunction of an AWINIC Technology product can reasonably be expected to result in personal injury, death or severe property or environmental damage. AWINIC Technology accepts no liability for inclusion and/or use of AWINIC Technology products in such equipment or applications and therefore such inclusion and/or use is at the customer's own risk.

Applications that are described herein for any of these products are for illustrative purposes only. AWINIC Technology makes no representation or warranty that such applications will be suitable for the specified use without further testing or modification.

All products are sold subject to the general terms and conditions of commercial sale supplied at the time of order acknowledgement.

Nothing in this document may be interpreted or construed as an offer to sell products that is open for acceptance or the grant, conveyance or implication of any license under any copyrights, patents or other industrial or intellectual property rights.

Reproduction of AWINIC information in AWINIC data books or data sheets is permissible only if reproduction is without alteration and is accompanied by all associated warranties, conditions, limitations, and notices. AWINIC is not responsible or liable for such altered documentation. Information of third parties may be subject to additional restrictions.

Resale of AWINIC components or services with statements different from or beyond the parameters stated by AWINIC for that component or service voids all express and any implied warranties for the associated AWINIC component or service and is an unfair and deceptive business practice. AWINIC is not responsible or liable for any such statements.