

# GBU8A-GBU8M

Silicon Bridge Rectifiers

**VOLTAGE RANGE: 50 --- 1000 V**

**CURRENT: 8.0A**



## GBU

### Features

- ◇ Rating to 1000V PRV
- ◇ Surge overload rating to 200 Amperes peak
- ◇ Ideal for printed circuit board
- ◇ Reliable low cost construction utilizing molded plastic technique results in inexpensive product
- ◇ Lead solderable per MIL-STD-202 method 208
- ◇ Glass passivated junctions

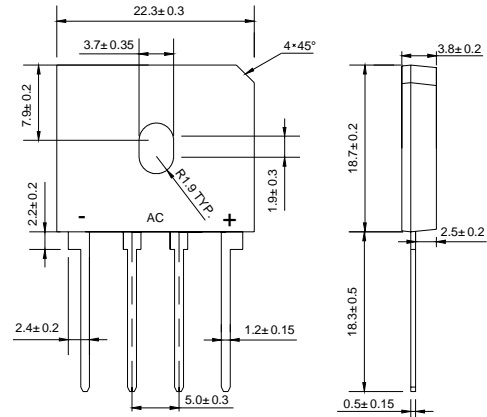

Dimensions in millimeters

### MAXIMUM RATINGS AND ELECTRICAL CHARACTERISTICS

Ratings at 25°C ambient temperature unless otherwise specified.

Single phase, half wave, 60 Hz, resistive or inductive load. For capacitive load, derate by 20%.

		GBU 8A	GBU 8B	GBU 8D	GBU 8G	GBU 8J	GBU 8K	GBU 8M	UNITS
Maximum recurrent peak reverse voltage	$V_{RRM}$	50	100	200	400	600	800	1000	V
Maximum RMS voltage	$V_{RMS}$	35	70	140	280	420	560	700	V
Maximum DC blocking voltage	$V_{DC}$	50	100	200	400	600	800	1000	V
Maximum average forward output current @ $T_C=100^\circ\text{C}$	$I_{F(AV)}$	8.0							A
Peak forward surge current 8.3ms single half-sine-wave superimposed on rated load	$I_{FSM}$	200.0							A
Maximum instantaneous forward voltage @ 4.0 A	$V_F$	1.0							V
Maximum reverse current @ $T_A=25^\circ\text{C}$ at rated DC blocking voltage @ $T_A=125^\circ\text{C}$	$I_R$	5.0 0.5							$\mu\text{A}$ mA
Operating junction temperature range	$T_J$	- 55 ---- + 150							$^\circ\text{C}$
Storage temperature range	$T_{STG}$	- 55 ---- + 150							$^\circ\text{C}$

## Ratings AND Characteristic Curves

**FIG.1 – TYPICAL FORWARD CURRENT DERATING CURVE**

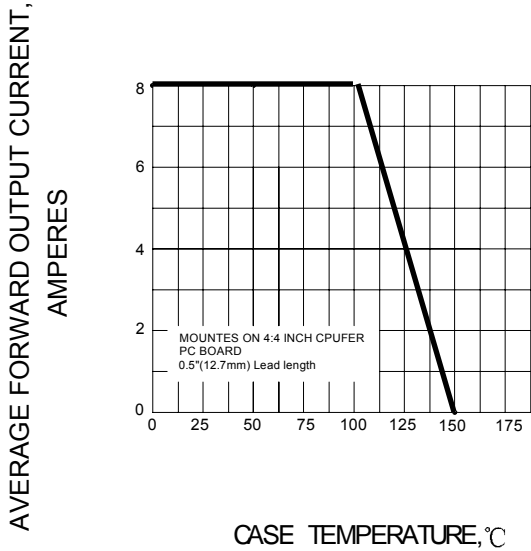

**FIG.2 – MAXIMUM FORWARD SURGE CURRENT**

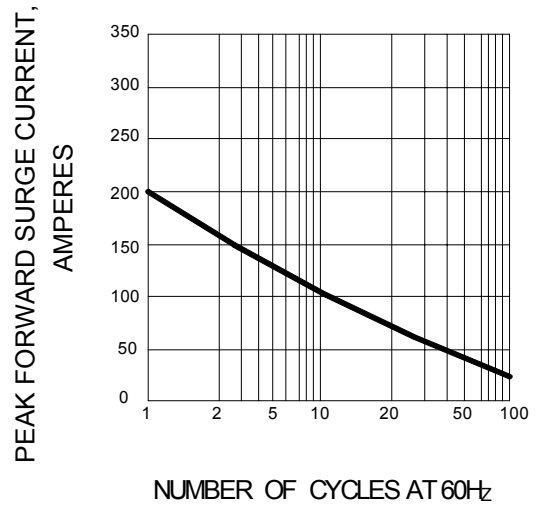

**FIG.3 – TYPICAL FORWARD CHARACTERISTIC**

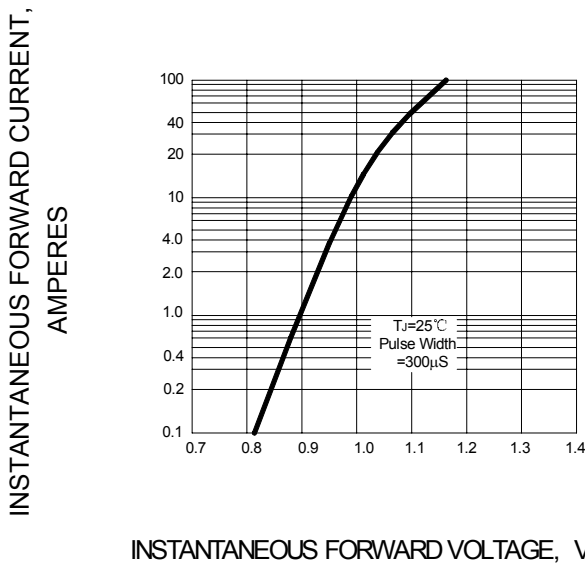

**FIG.4 – TYPICAL REVERSE CHARACTERISTIC**

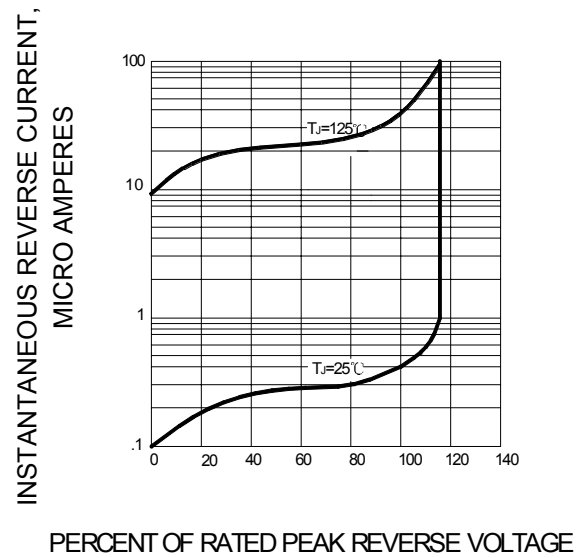

**FIG.5 – TYPICAL JUNCTION CAPACITANCE PER ELEMENT**

