

CERTI-CRIMP II SAHT

Standard Straight Action Hand Tool Design
Widely used in the Aircraft and Military industries

Image representative of type only

Features:

Fixed dies
Straight action jaw closure
Ratchet mechanism ensures complete crimp cycle
Emergency only ratchet release
Terminal/wire positioning aids & Ins. adjustment on most tools
Ergonomic non-slip handles
Approximate weight 0.59 kg (1.3 lbs)



Part Number	Description	mm ² (AWG) or other
91572-1	AMP CT 2.0 Receptacle	0.12 - 0.4 (26-22)
91576-1	AMP DYNAMIC D-2	0.08 - 0.22 (28-24)
91595-1	AMP DYNAMIC D-2	0.4 - 1.0 (22-18)
91559-1	AMP DYNAMIC D-3	0.2 - 0.6 (24-20)
91558-1	AMP DYNAMIC D-3	0.6 - 1.5 (20-16)
91537-1	AMP MOD II FFC	0.15 - 0.4 (26-22)
91516-1	AMP MOD IV	0.05 - 0.6 (30-20)
91517-1	AMP MOD IV, V	0.15 - 0.4 (26-22)
91549-1	AMPLIMITE HD-20	0.08 - 0.22 (28-24)
91503-1	AMPLIMITE HD-20	0.08 - 0.6 (28-20)
91548-1	AMPLIMITE HD-20	0.08 - 0.6 (28-20) No Ins. Crimp
91525-1	AMPLIMITE HD-20	0.15 - 0.4 (26-22)
91513-1	AMPLIMITE HD-20	0.4 - 1.0 (22-18) No Ins. Crimp
91520-1	AMPLIMITE HD-22	0.08 - 0.4 (28-22)
91512-1	Commercial MATE-N-LOK	0.2 - 0.96 (24-18) Ins. Ø1.52-2.54mm
91504-1	Commercial MATE-N-LOK	0.6 - 2.5 (20-14)
1901963-1	MATE-N-LOK 3.5 (.140)	0.5 - 2.1 (20-14)
91502-1	Micro MATE-N-LOK	0.05 - 0.12 (30-26)
91501-1	Micro MATE-N-LOK	0.2 - 0.6 (24-20)
91540-1	Mini Tandem-Spring Pin	0.03 - 0.4 (32-22)
91536-1	Mini-Universal MATE-N-LOK "F" Ins. Crimp	[20-16]
91529-1	Mini-Universal MATE-N-LOK	0.15 - 0.4 (26-22)
91522-1	Mini-Universal MATE-N-LOK	0.4 - 1.0 (22-18)
91594-1	Mini-Universal MATE-N-LOK, type "O" Ins. Crimp	0.5 - 1.42 (20-16)
91577-1	MULTILOCK 040	0.4 - 0.6 (22-20)
91588-1	MULTILOCK 040 MkII	0.6 - 1.0 (20-18)
91542-1	TYPE III+	0.2 - 0.6 (24-20)
91505-1	TYPE III+	0.2 - 1.42 (24-16) Ins. Ø1.14-2.54mm
91523-1	TYPE III+	0.2 - 1.5 (24-16) Ins. Ø2.03-2.54mm
91521-1	TYPE III+	1.0 - 2.5 (18-14)
91515-1	TYPE III+; Type VI; Commercial MATE-N-LOK	0.05 - 0.6 (30-20)
91510-1	Universal MATE-N-LOK	0.2 - 0.96 (24-18)
91506-1	Universal MATE-N-LOK	1.2 - 2.1 (16-14) Ins. Ø3.30-5.08mm

CERTI-CRIMP II SAHT - Short Handle

Ideal for working in confined spaces
 Widely used in the Aircraft and Military industries

Image representative of type only

Features:

- Fixed dies
- Straight action jaw closure
- Ratchet mechanism ensures complete crimp cycle
- Emergency only ratchet release
- Terminal/wire positioning aids & Ins. adjustment on most tools
- Ergonomic non-slip handles
- Approximate weight 0.5 kg (1.1 lbs)



Part Number	Description	mm ² (AWG) or other
1901611-2	PIDG STRATO-THERM Terminals & Splices	0.2 - 0.6 (24-20)
1901600-2	PIDG STRATO-THERM Terminals & Splices	1.0 - 1.5 (18-16)

CERTI-CRIMP II SAHT - Long Handle

Low handle force for ease of operation
 Widely used in the Aircraft and Military industries

Image representative of type only

Features:

- Fixed dies
- Straight action jaw closure
- Ratchet mechanism ensures complete crimp cycle
- Emergency only ratchet release
- Terminal/wire positioning aids & Ins. adjustment on most tools
- Ergonomic non-slip handles
- Approximate weight 0.59 kg (1.3 lbs)



Part Number	Description	mm ² (AWG) or other
1901611-1	PIDG STRATO-THERM Terminals & Splices	0.2 - 0.6 (24-20)
1901600-1	PIDG STRATO-THERM Terminals & Splices	1.0 - 1.5 (18-16)

CERTI-CRIMP II SAHT - Head Assy

Head only for use with Power Assist options

Image representative of type only

Features:

Heads can be removed from Hand Tools, or are also available as a [-3] option.

Example 91500-1 CERTI-CRIMP II SAHT; the head can be removed from the handles and used along with this adapter on the Electric Terminator . Alternatively 91500-3 (head only) is also available.

Use with:

BT 3500 Battery-Hydraulic Hand Tools:

2-2031400-1 + CCII Adapter 2031480-1 - EMEA

or

3-2031400-1 + CCII Adapter 2031480-1 - UK

1583527-1 Micro Pneumatic Adapter

1213860-1 Adapter Electric Terminator EU

see Power Assist section for more information

Double Action Hand Tool

Note: The approvals shown against the tools listed are only applicable when using terminals and wires recommended for the relevant industry.

Image representative of type only

Widely used in Aircraft and Military applications

Features:

Fixed dies

Ratchet mechanism ensures complete crimp cycle

Emergency only ratchet release

Terminal/wire positioning aids & Ins. adjustment on many tools

Ergonomic non-slip handles

Approximate weight 0.54 kg (1.2 lbs)



Part Number	Description	mm ² (AWG) or other
45216	PIDG Closed End Splice	1.0 - 1.5 (18-16)
47386	PIDG & PLASTI-GRIP Terminals; PIDG Splices Standard tool for GB Railways - Qualified; Mil-T-7928/7; LUL RSE 024 pt6 & EE6161 Marks the applied product with a one dot indent code.	0.4 - 1.5 (22-16)
47386-5	PIDG & PLASTI-GRIP Terminals; PIDG Splices French Special - Qualified; Mil-T-7928 - AMP specified level Marks the applied product with a one dot indent code. Includes French Instruction Sheet	0.4 - 1.5 (22-16)
47387	PIDG & PLASTI-GRIP Terminals; PIDG Splices Standard tool for GB Railways - Qualified; Mil-T-7928; LUL RSE 024 pt6 & EE6161 Marks the applied product with a two dot indent code.	1.25 - 2.0 (16-14) 0.6 - 1.5 (20-16) HD
47386-4	PIDG & PLASTI-GRIP Terminals; PIDG Splices & FASTON EMEA Special - Qualified; Mil-T-7928 - AMP specified level for Ringtongues only Marks the applied product with a one dot indent code.	0.4 - 1.5 (22-16)
47387-7	PIDG & PLASTI-GRIP Terminals; PIDG Splices & FASTON EMEA Special - Qualified; Mil-T-7928 - AMP specified level for Ring Tongues only Marks the applied product with a two dot indent code.	1.5 - 2.5 (16-14) 0.6 - 1.5 (20-16) HD
90035-3	PIDG FASTON - Special GB Railways Tool Qualified; LUL RSE 024 pt6 & EE6161	0.4 - 1.0 (22-18)
90009-8	PIDG FASTON - Special GB Railways Tool Qualified; LUL RSE 024 pt6 & EE6161	1.5 - 2.5 (16-14)
482930-1	Special French tool for PIDG FASTON 2.8 (.110) with crimp orientation at 90° Marks the applied product with a one dot indent code.	0.15 - 0.4 (26-22)
47907-1	PIDG Terminals & Splices	0.2 - 0.56 (24-20)
46121	PIDG Terminals & Splices; PLASTI-GRIP Butt Splices Marks the applied product with a one dot indent code	0.15 - 0.4 (26-22)
47304	PIDG Terminals & Splices; PLASTI-GRIP Butt Splices for thin wall insulation Marks the applied product with a one dot indent code	0.15 - 0.4 (26-22)
525690	Special GB Aerospace & MOD PIDG & PLASTI-GRIP Ring Tongue Tool - approved DEF. STAN. 59-71 (Pt. 1). Equivalent to 47386 but has special retaining pins/rings to reduce the risk of tool parts falling off whilst building and maintaining aircraft.	0.6 - 1.0 (20-18)
525691	Special GB Aerospace PIDG & PLASTI-GRIP Ring Tongue Tool. Equivalent to 47387 but has special retaining pins/rings to reduce the risk of tool parts falling off whilst building and maintaining aircraft.	1.25 - 2.0 (16-14)
753786-1	POSITIVE LOCK 4.8 [.187] Mk II Receptacle	0.70 - 2.08 (20-14)
753815-1	POSITIVE LOCK 6.3 [.250] Mk II Tablock Flag Receptacle	2.0 - 3.37 [14-12]
69363	SOLISTRAND Terminals & Splices - Standard Tool. Qualified; Mil-T-7928; LUL RSE 024 pt6 & EE6161	0.15 - 0.6 (26-20)
49935	SOLISTRAND Terminals & Splices Qualified; Mil-T-7928; LUL RSE 024 pt6 & EE6161	0.4 - 6.0 (22-10)
525693	Special tool for SOLISTRAND Terminals & Splices (GB) Equivalent to 49935 but has special retaining pins/rings to reduce the risk of tool parts falling off whilst building and maintaining aircraft.	0.4 - 6.0 (22-10)
49592	SOLISTRAND Terminals & Splices Qualified; Mil-T-7928; LUL RSE 024 pt6 & EE6161	2.5 - 4.0 (14-12)
46447	SOLISTRAND STRATO-THERM High Temp & Heat Resistant Terminals & Splices	0.4 - 6.0 (22-10)
46673	STRATO-THERM Uninsulated Terminals & Splices	0.4 - 1.5 (22-16)
46673-1	STRATO-THERM Uninsulated Terminals & Splices [thin wall cable]	0.4 - 1.5 (22-16) [thin wall cable]

where listed, only popular tools show - please use our online search for the latest information:

<http://www.tooling.tycoelectronics.com/europe/Handtools.asp>

Adapter - Double Action Hand Tool to 626 Pneumatic

1213563-1 - Adapter only

Features:

Heads can be removed from Hand Tools, example:
the Handles from 47386 can be removed and the head used with
this Adapter (includes cam).

Also required:

Hand held power unit 189721-1

or

Foot actuated Power Unit 189722-1

for more information, please see the Power Assist section

Image representative of type only

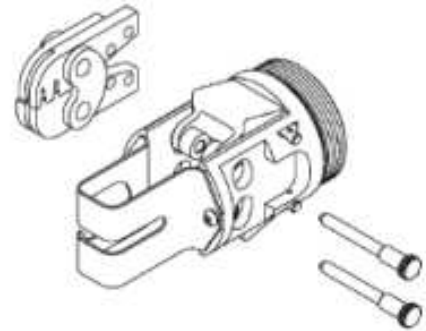

C-Head SAHT

69710-1 - Base Tool without Die-set

Widely used in Aircraft and Military applications

Can be used with all C-Head SAHT Dies

Features:

Interchangeable Dies

Straight action jaw closure

Ratchet mechanism ensures complete crimp cycle

Emergency only ratchet release

Approximate weight 0.86 kg (1.9 lbs)

Image representative of type only



C-Head SAHT - LD

1901260-1 Base Tool without Die-set

A light duty alternative to 69710-1

Can be used with all C-Head SAHT Dies EXCEPT:

- Die-set - C-Head SAHT - HD
- Through Splice applicators

Features:

Interchangeable Dies

Straight action jaw closure

Ratchet mechanism ensures complete crimp cycle

Emergency only ratchet release

Ergonomic non-slip handles

Approximate weight 0.5 kg (1.1 lbs)

Image representative of type only



Die-set - C-Head SAHT

A range of Die-sets for many premium crimp applications

Features:

Use in:

Hand Tool Frame 69710-1

Hand Tool Frame 1901260-1 (see restrictions)

Power Assist options:

BT 3500 Battery-Hydraulic Hand Tools:

2-2031400-1 + C-Head SAHT Adapter 2119810-1 - EMEA

or

3-2031400-1 + C-Head SAHT Adapter 2119810-1 - UK

1901556-1 Adapter Electric Terminator EU

1-528051-8 Adapter Bench Press AT-SC

Image representative of type only

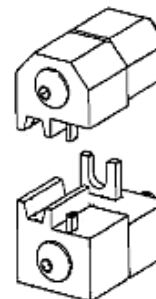

For more information see the Power Assist section

Part Number	Description	mm ² (AWG) or other
58212-1	AMPLIMITE	RG 142, 142A, 142B
576711	PIDG STRATO-THERM Terminals with PTFE or PEEK for thin-wall Insulation	0.2 - 0.4 (24-22)
576720	PIDG STRATO-THERM Terminals with PTFE or PEEK for thin-wall Insulation	0.5 (20)
576715	PIDG STRATO-THERM Terminals with PTFE or PEEK for thin-wall Insulation	1.0 (18)
576714	PIDG STRATO-THERM Terminals with PTFE or PEEK for thin-wall Insulation	1.5 (16)
47807-1	PIDG, PLASTI-GRIP Terminals & Splices	1.5 - 2.5 (16-14)
47806-2	PIDG, PLASTI-GRIP, Terminals & Splices	0.4 - 1.5 (22-16)
1-539634-9	Pin / Socket size 8	Gore Cable Type: GSC-03-81748-00

Die-set - C-Head SAHT - HD

A range of Heavy Duty Die-sets for many premium crimp applications

Features:

Use in:

Hand Tool Frame 69710-1

Power Assist options:

1901556-1 Adapter Electric Terminator EU

1-528051-8 Adapter Bench Press AT-SC

Image representative of type only

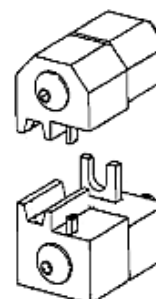

For more information see the Power Assist section

Part Number	Description	mm ² (AWG) or other
59993-1	AMPLIMITE	8 (10)
69735	PIDG STRATO-THERM Terminals & Splices with PTFE Insulation	4.0 - 6.0 (12-10)
576716	PIDG STRATO-THERM Terminals with PTFE or PEEK for thin-wall Insulation	2.5 (14)
576742	PIDG STRATO-THERM Terminals with PTFE or PEEK for thin-wall Insulation	4.0 (12)
576723	PIDG STRATO-THERM Terminals with PTFE or PEEK for thin-wall Insulation	6.0 (10)
47808-6	PIDG, PLASTI-GRIP Terminals & Splices	4.0 - 6.0 (12-10)
90145-1	TYPE XII Contact	2.5 - 4.0 (14-12)
90140-1	TYPE XII Contact	6.0 - 10.0 (10-8)
58380-1	Universal MATE-N-LOK	3.0 (12)
58380-2	Universal MATE-N-LOK	5.0 (10)

where listed, only popular tools show - please use our online search for the latest information:

<http://www.tooling.tycoelectronics.com/europe/Handtools.asp>

Heavy Head Hand Tool

Note: The specifications shown against the tools listed are only applicable when using terminals recommended for the relevant industry
Widely used in Aircraft and Military applications

Image representative of type only

Features:

Fixed dies
Straight action jaw closure
Ratchet mechanism ensures complete crimp cycle
Emergency only ratchet release
Terminal/wire positioning aids & Ins. adjustment on most tools
Approximate weight 0.95 kg (2.1 lbs)



Part Number	Description	mm ² (AWG) or other
234170-1	AMP DYNAMIC D-5	1.5 - 2.5 (16-14)
234171-1	AMP DYNAMIC D-5	4.0 - 6.0 (12-10)
1366044-1	AMP DYNAMIC D-5 Receptacle	8.0 (10)
90246-1	PIDG FASTON - Standard tool	2.5 - 4.0 (14-12)
90276-2	PIDG FASTON Qualified; LUL RSE 024 pt6 & EE6161	4.0 - 6.0 (12-10) 1.5 - 2.5 (16-14) HD
484364-1	PIDG STRATO-THERM Terminals & Splices	1.0 (18)
576782	Special GB Aerospace tool for PIDG STRATO-THERM Terminals with PTFE or PEEK for thin-wall Insulation Qualified to BS 4G178	2.5 (14)
576783	Special GB Aerospace tool for PIDG STRATO-THERM Terminals with PTFE or PEEK for thin-wall Insulation Qualified to BS 4G178	4.0 (12)
576784	Special GB Aerospace tool for PIDG STRATO-THERM Terminals with PTFE or PEEK for thin-wall Insulation Qualified to BS 4G178	6.0 (10)
576778	Special GB Aerospace tool for PIDG STRATO-THERM Terminals with PTFE or PEEK for thin-wall Insulation Qualified to BS 4G178	0.2 - 0.4 (24-22)
576779	Special GB Aerospace tool for PIDG STRATO-THERM Terminals with PTFE or PEEK for thin-wall Insulation Qualified to BS 4G178	0.6 (20)
576780	Special GB Aerospace tool for PIDG STRATO-THERM Terminals with PTFE or PEEK for thin-wall Insulation Qualified to BS 4G178	1.0 (18)
576781	Special GB Aerospace tool for PIDG STRATO-THERM Terminals with PTFE or PEEK for thin-wall Insulation Qualified to BS 4G178	1.5 (16)
59239-4	PIDG, PLASTI-GRIP Terminals & Splices - Standard tool for GB Railways Qualified; Mil-T-7928; LUL RSE 024 pt6 & EE6161 Marks the applied product with a one dot indent code.	3.0 - 5.0 (12-10) 1.5 - 2.5 (16-14) HD
59287-2	PIDG, PLASTI-GRIP Large Expansion Terminals & Splices	4.0 - 6.0 (12-10) (16-14) HD
525692	Special GB Aerospace & MOD PIDG & PLASTI-GRIP Ring Tongue Tool - approved DEF. STAN. 59-71 (Pt. 1). Equivalent to 59239-4 but has special retaining pins/rings to reduce the risk of tool parts falling off whilst building and maintaining aircraft.	4.0 - 6.0 (12-10)
69355	SOLISTRAND Terminals & Splices	10.0 (8)
59461	STRATO-THERM Uninsulated Terminals & Splices with Insulation Support	4.0 - 6.0 (12-10) (16-14) HD
90382-2	TYPE XII Contact	1.5 - 4.0 (16-12)
90384-1	TYPE XII Contact	6.0 - 10.0 (10-8)

Adapter - Heavy Head to 626 Pneumatic

525432-1 - Adapter only

Features:

Heads can be removed from Hand Tools, example: the Handles from 59239-4 can be removed and the head used with this Adapter on the 626 Pneumatic system.

Also required:

Adapter Holder with Ratchet 356304-1
or Adapter Holder without Ratchet 189928-1
and

Hand held power unit 189721-1
or Foot actuated Power Unit 189722-1

see Power Assist section for more information

Image representative of type only

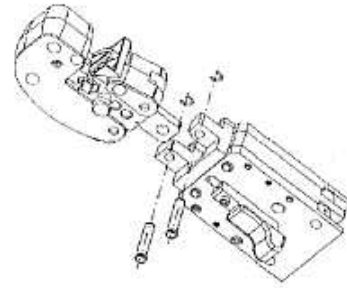

Reel-Fed CERTI-LOK

A unique tool that applies terminals from special small reels

Features:

Terminal feeding and cutting device
Straight action jaw closure
Ratchet mechanism ensures complete crimp cycle
Easy access ratchet release
Handle pressure adjustment with locking device
Ergonomic non-slip handles

Image representative of type only



Part Number	Description	mm ² (AWG) or other
539608-1	AMP MOD II	0.02 - 0.20 (32-24)
734203-1	AMP MOD IV	0.12 - 0.14 (26)
734204-1	AMP MOD IV	0.2 - 0.56 (24-20)
734643-1	AMPLIVAR	
734870-2	MICRO MATCH COSI contact	0.08 - 0.2 (28-24)
734870-1	MICRO MATCH COSI contact	0.2 - 0.6 (24-20)
734216-1	TYPE III+	0.2 - 1.5 (24-16)

CERTI-LOK

Features:

- Interchangeable Dies
- Straight action jaw closure
- Ratchet mechanism ensures complete crimp cycle
- Easy access ratchet release
- Handle pressure adjustment with locking device
- Ergonomic non-slip handles
- Approximate weight 0.64 kg (1.4 lbs)

Image representative of type only



Part Number	Description	mm ² (AWG) or other
169400	Base Tool without Die-set - Approved DEF. STAN. 59-71 (Pt. 1)	

Adapter - CERTI-LOK to Electric Terminator

169411 - Adapter only

Features:

Adapts the Electric Terminator 539630-1 to take CERTI-LOK Dies

for more information on the Press and Press options, please see the Power Assist section

Image representative of type only



PEZ 100

539717-1 - Base Tool without Die-set

1579000-1 - Base Tool without Die-set Long Handles

Features:

- Interchangeable Dies
- Flap type terminal locator
- Straight action jaw closure
- Ratchet mechanism ensures complete crimp cycle
- Easy access ratchet release
- Handle pressure adjustment with locking device
- Ergonomic non-slip handles

Image representative of type only



ERGOCRIMP

539635-1 - Base tool without Die-set

Note: This tool is not compatible with SDE Dies

Image representative of type only

Features:

- Interchangeable Dies
- Virtually a straight action jaw closure
- Ratchet mechanism ensures complete crimp cycle
- Easy access ratchet release
- Handle pressure adjustment with locking device
- Ergonomic non-slip handles
- Approximate weight 0.59 kg (1.3 lbs)

Spare parts Kit 539635-2 (excluding main spring)
Main Spring PN 1579005-1



Tetra-Crimp Hand Tool

58078-3 - Base Tool without Die-set

Image representative of type only

Features:

- Interchangeable Dies
- Ratchet mechanism ensures complete crimp cycle
- Tamper proof ratchet release setting
- Emergency ratchet release feature
- Terminal locator / support and wire stop on many tools
- Approximate weight 0.64 kg (1.4 lbs)
- Ergonomic non-slip handles



Part Number	Description	mm ² (AWG) or other
58052-3	Die-set for ULTRA FAST	0.15 - 0.4 (26-22)
90390-3	Die-set for ULTRA FAST (including Flag Terminals)	0.4 - 1.0 (22-18)
90391-3	Die-set for ULTRA FAST (including Flag Terminals)	1.5 - 2.5 (16-14)
58079-3	Die-set for ULTRA FAST PLUS	0.4 - 1.0 (22-18)
58080-3	Die-set for ULTRA FAST PLUS	1.5 - 2.5 (16-14)

Mini CERTI-LOK

A light weight and compact tool for many commercial applications

Image representative of type only

Features:

- Fixed dies
- Straight action jaw closure
- Ratchet mechanism ensures complete crimp cycle
- Easy access ratchet release
- Handle pressure adjustment with locking device
- Easy terminal positioning with 'Flap Locator' (some tools)
- Ergonomic non-slip handles
- Approximate weight 0.46 kg (1.0 lbs)



Modular Mini CERTI-LOK

Based on the Mini Certi-Lok tool

Features:

Heads with identical features to the Mini Certilok tool

Choice of two handle lengths:

2-1579005-1 Short Handle

2-1579005-2 long Handle

Interchangerbility via snap-in pins.

Image representative of type only



C-Frame Hand Tool

6-1419172-9 - Base Tool without Die-set

Features:

Interchangeable Dies

Double action jaw closure

Ratchet mechanism ensures complete crimp cycle

Easy access ratchet release

Handle pressure adjustment with locking device

Egonomic non-slip handles

Approximate weight 0.55 kg (1.2 lbs)

Image representative of type only



Part Number	Description	mm ² (AWG) or other
1583684-1	Die-set for ADK Series Back Shell	6.0 mm Cable Dia Max
1583684-2	Die-set for ADK Series Back Shell	7.5 mm Cable Dia Max
1583684-3	Die-set for ADK Series Back Shell	8.5 mm Cable Dia Max
1583684-4	Die-set for ADK Series Back Shell	9.5 mm Cable Dia Max
948761-1	Complete tool for HDE20 Ferrule	Cable Ø4.8 - 6.3
948761-2	Complete tool for HDE 20 Ferrule	Cable Ø6.3 - 8.2
948761-3	Complete tool for HDE20 Ferrule	Cable Ø8.2 - 11.1
734566-1	Complete tool for N Series 50 & 70 ohm	

D-Frame Tool

Features:

Fixed Die-sets
 Small and lightweight
 Ratchet mechanism ensures complete crimp cycle
 Easy access ratchet release
 Handle pressure adjustment with locking device
 Ergonomic non-slip handles
 Approximate weight 0.55 kg (1.2 lbs)

Image representative of type only



Part Number	Description	mm ² (AWG) or other
947488-1	Coax - BNC, TNC	Cable Dia 5 & 6mm
947679-1	HE 13 / 14 Crimp-on Snap-in	0.08 - 0.2 (28-24)
2-1579002-0	Wire Wire End Ferrules (Square crimp form)	0.5 - 6.0 (20-10)

Trapezium Crimp Tool

Special Trapezium crimp tool for Wire End Ferrule applications

Features:

Ratchet mechanism ensures complete crimp cycle
 Easy access ratchet release
 Handle pressure adjustment with locking device
 Ergonomic non-slip handles

Image representative of type only



Part Number	Description	mm ² (AWG) or other
734641-2	Wire End Ferrules (trapezium crimp form)	0.14 - 6.0 (26-10)
734641-3	Wire End Ferrules (trapezium crimp form)	0.5 - 10 (20-6)
734641-4	Wire End Ferrules (trapezium crimp form)	10.0 - 16.0 (8-6)

Square Crimp Tool

Special Square crimp tool for Wire End Ferrule applications

Features:

- Ratchet mechanism ensures complete crimp cycle
- Easy access ratchet release
- Handle pressure adjustment with locking device
- Ergonomic non-slip handles

Image representative of type only



Part Number	Description	mm ² (AWG) or other
539660-1	Wire Wire End Ferrules (square crimp form)	0.08 - 10.0 (28-7)
539661-1	Wire Wire End Ferrules (square crimp form)	0.75 - 10 (20-8)
7-1579014-0	Wire End Ferrules DIN 46228 Pt. 1 & 4 - crimp length 13mm. Crimp is indented on two sides only - (better for smaller sizes)	0.08 - 10.0 (28-7)

Service Tool

734790-1 - Base Tool without Die-set

Features:

- Interchangeable Dies
- Ratchet mechanism ensures complete crimp cycle
- Easy access ratchet release
- Handle pressure adjustment with locking device
- Ergonomic non-slip handles
- Approximate weight 0.59 kg (1.3 lbs)

Image representative of type only



TERMI-POINT Service Tool

Features:

For the repair of crimped connections

Image representative of type only



Part Number	Description	mm ² (AWG) or other
654632-1	Service Tool without Mandrel for Maxi TERMI-POINT	
654633-1	Twin Mandrel (Yellow / Red) for 654632-1	[24-20]
655136-3	Service Tool without Mandrel - Standard TERMI-POINT	0.2 - 0.4 (24-22)

TERMI-POINT Hand Tool

Features:

- Pneumatic options (pictured)
- Interchangeable Mandrels
- Terminals fed from Reel

Image representative of type only



Part Number	Description	mm ² (AWG) or other
871295-5	Mandrel (brown) for Maxi TERMI-POINT Tool 871087-2	0.15 (26) Ins. Ø0.76-1.40mm
871295-2	Mandrel (red) for Maxi TERMI-POINT tool 871087-1	0.2 (24) Ins. Ø0.86-1.65mm
871295-4	Mandrel (red) for Maxi TERMI-POINT Tool 871087-2	0.2 (24) Ins. Ø0.86-1.65mm
69561-4	Mandrel (red) for Maxi TERMI-POINT tool 654182-1	0.2 (24) Ins. Ø1.1 -1.65mm
871295-3	Mandrel (orange) for Maxi TERMI-POINT Tool 871087-2	0.4 (22) Ins. Ø0.91-1.65mm
871295-1	Mandrel (yellow) for Maxi TERMI-POINT tool 871087-1	0.56 (20) Ins. Ø0.91-1.65mm
69561	Mandrel (yellow) for Maxi TERMI-POINT tool 654182-1	0.56 (20) Ins. Ø1.17-1.65mm
69561-1	Mandrel (yellow) for for Maxi TERMI-POINT tool 654182-1	0.56 (20) Ins. Ø1.68-2.16mm
654182-1	Hand Tool without Mandrel - Maxi TERMI-POINT	0.6 - 0.2 (20-24)
871087-1	Hand Tool (pneumatic) without Mandrel - Maxi TERMI-POINT	0.6 - 0.2 (20-24)
69526-2	Hand Tool without Mandrel - Standard TERMI-POINT	0.08 - 0.4 (28-22)
69551-5	Mandrel (black) for Standard TERMI-POINT Tool 69526-2	0.08 (28) Ins. Ø1.14-1.65mm
69551-6	Mandrel (brown) for Standard TERMI-POINT Tool 69526-2	0.15 (26) Ins. Ø0.56-1.14 mm
1-69411-9	Mandrel (brown) for Standard TERMI-POINT Tool 69526-2	0.15 (26) Ins. Ø1.14-1.65mm
69551-9	Mandrel (red) for Standard TERMI-POINT Tool 69526-2	0.2 (24) Ins. Ø0.74-1.23mm
1-69411-3	Mandrel (red) for Standard TERMI-POINT Tool 69526-2	0.2 (24) Ins. Ø1.10-1.65mm
871087-2	Hand Tool (pneumatic) without Mandrel - Standard TERMI-POINT	0.4 - 0.15 (22-26)
69551-8	Mandrel (orange) for Standard TERMI-POINT Tool 69526-2	0.4 (22) Ins. Ø0.87-1.23mm
1-69411-4	Mandrel (orange) for Standard TERMI-POINT Tool 69526-2	0.4 (22) Ins. Ø1.14-1.65mm

Service Kit Tool

Ideal for Service and Repair

Features:

- Tool-less Die change
- Ratchet mechanism ensures complete crimp cycle
- Emergency ratchet release feature
- Ergonomic non-slip handles
- Approximate weight 0.46 kg (1.0 lbs)

Image representative of type only



Part Number	Description	mm ² (AWG) or other
3-1579000-0	Hand Tool Frame only - Service Kit Tool	

Die-set - Service Kit Tool

Build up your own kit!

Features:

- Upper & lower Dies are permanently joined
- Interlocking Die-set holders

Use in Service Kit Tool 3-1579000-0

Image representative of type only



Part Number	Description	mm ² (AWG) or other
3-1579016-4	FASTON 6.3 [.250]	0.5 - 6.0 (20-10)
3-1579016-1	PIDG, PLASTIGRIP Terminals & Splices	0.1 - 6.0 (26-10) Green / Yellow
3-1579016-2	PIDG, PLASTIGRIP Terminals & Splices	0.5 - 2.5 (20-14) Red / Blue
3-1579016-3	SOLISTRAND Terminals & Splices	0.5 - 6.0 (20-10)
3-1579016-5	Wire End Ferrules	0.25 - 10.0 (24-8)