

Installation and Technical Manual for the Limitless™ Wireless Operator Interface WOI Series

Issue 1

50077275

Used in conjunction with the Limitless™ WPMM or WDRR Series

⚠ WARNING **PERSONAL INJURY**

DO NOT USE these products as safety or emergency stop devices or in any other application where failure of the product could result in personal injury.

Failure to comply with these instructions could result in death or serious injury.

⚠ WARNING

Honeywell does not recommend using devices for critical control applications where there is, or may be, a single point of failure or where single points of failure may result in an unsafe condition. It is up to the end-user to weigh the risks and benefits to determine if the products are appropriate for the application based on security, safety and performance. Additionally, it is up to the end-user to ensure that the control strategy results in a safe operating condition if any crucial segment of the control solution fails. Honeywell customers assume full responsibility for learning and meeting the required Declaration of Conformity, Regulations, Guidelines, etc. for each country in their distribution market.

⚠ WARNING **RF EXPLOSURE**

To satisfy FCC RF exposure requirements for mobile transmitting devices, a separation distance of 20 cm or more should be maintained between the antenna of this device and persons during device operation. To ensure compliance, operation at closer than this distance is not recommended. The antenna used for this transmission must not be co-located in conjunction with any other antenna or transmitter.

Failure to comply with these instructions could result in death or serious injury.

⚠ WARNING

The WOI must be installed in accordance with the requirements specified in this document in order to comply with the specific Country Communication Agency requirements. (i.e. FCC, IC, ETSI, ACMA, etc.) See Section 3 as it requires choosing the correct Country Use Code and thus allowable antenna and/or cable usage.

CAUTION

Power to the WOI should not be applied (ensure battery is removed) during installation of antenna as damage could occur to the WOI electronics.

TABLE OF CONTENTS

1	DESCRIPTION	1
1.1	General	1
1.2	Principle of Operation	1
1.3	Model Reference	1
1.4	Abbreviations and Definitions	2
1.5	Symbol Definitions	3
2	SPECIFICATIONS	4
2.1	Intended Country Usage	4
2.2	Certification and Approvals	5
2.3	Radio Module Specifications	5
2.4	Electrical Specifications	5
2.5	EMC Specifications	5
2.6	Environmental Specifications	6
2.7	Agency Compliance Information	6
2.7.1	FCC Compliance Statements	6
2.7.2	IC Compliance Statements	6
2.7.3	Radio Frequency (RF) Safety Statement (FCC & IC)	6
2.7.4	European Restrictions	6
2.8	European (CE) Declaration of Conformity (DoC)	7
2.8.1	European Declaration of Conformity Statements	7
2.8.2	For more information about the R&TTE Directive	8
3	ANTENNA OPTIONS ALLOWED PER COUNTRY USE CODE	9
3.1	COUNTRY USE CODE “A” ANTENNA OPTIONS	9
3.2	COUNTRY USE CODE “B” ANTENNA OPTIONS	10
4	QUICK START UP	11
4.1	Antenna Connection	11
4.2	End User Switch Connection (if applicable)	12
4.3	Battery Connection Procedure	14
4.4	Pairing Mode	15
4.5	WOI Purge Mode	18
4.6	WPMM/WDRR Operation and LED functions	19
4.6.1	Principle of Operation of the WPMM and Limitless™ WOI Switch	19
4.6.2	WDRR Operation and LED functions	19
5	ANTENNA CONSIDERATIONS/OPTIONS & INSTALLATION	20
5.1	Overview of Antenna Options	20
5.1.1	Omni-directional Antenna Design	21
5.2	Antenna Mounting and Considerations	22
5.2.1	Antenna Mounting Location with Respect to RF Signal	22
5.2.2	Outdoor Installation Warnings	23
5.2.3	Antenna Connection, Styles, and Mounting Options	24
5.2.3.1	Antenna Connection, Styles, and Mounting Options	24
5.2.3.2	Antenna Styles and Mounting Options	24
5.2.4	Antenna Adjustment Considerations	27

5.3	Signal Range of an Antenna	28
5.4	Choosing an Antenna Gain (dBi) With Acceptable Fade-Margin	28
5.5	Environment Usage/Concerns	29
5.5.1	Choosing an Antenna/Cable to Meet Application Exposure Conditions	29
5.5.2	Outdoor Antenna Installations - Lightning Concerns	30
5.5.3	RF Interference	30
5.6	WOI Mounting/Actuation	31
6	INSPECTION AND MAINTENANCE	32
6.1	WOI Inspection and Replacement	32
6.2	Antenna Inspection and Replacement	32
6.3	Battery Replacement	32
7	ACCESSORIES	34
7.1	Antenna Options	34
7.2	Antenna Cable Options	35
7.3	Mounting Options	35
8	INSTALLATION DRAWINGS	35
8.1	Drawing Availability	35
9	TROUBLESHOOTING GUIDES	36
9.1	WOI used in conjunction with a WPMM	36
9.2	WOI used in conjunction with a WDRR	39

List of Figures

Figure 1. European Declaration of Conformity (DoC)	7
Figure 2. Limitless™ WOI Mounting Hole Dimensions	12
Figure 3. Limitless™ WOI leadwires	13
Figure 4. Limitless™ WOI Housing	14
Figure 5. Limitless™ WOI Battery and Insulator	14
Figure 6. Limitless™ WOI Housing	16
Figure 7. Limitless™ WPMM Housing	16
Figure 8. Limitless™ WOI with Function Button Depressed	16
Figure 9. Limitless™ WOI Label Placement	16
Figure 10. Limitless™ WDRRa Housing	18
Figure 11. Radiation Pattern of an Omni-directional Antenna	21
Figure 12. WOI to WPMM or WDRR Antennas with RF Signal Line of Sight (LOS) Free From Obstacles	22
Figure 13. WOI to WPMM or WDRR Antennas with RF Signal Line of Sight (LOS) Affected by Obstacles	22
Figure 14. Limitless™ WOI RP-SMA Connection, Integral	24
Figure 15. Limitless™ WOI RP-SMA Connection, Remote	24
Figure 16. Straight and Tilt/Swivel antennas	25
Figure 17. Adhesive Mount Antenna – Step 1. Pre-clean the surface	25
Figure 18. Adhesive Mount Antenna – Step 2. Peel Protection from Adhesive Strip	25
Figure 19. Adhesive Mount Antenna – Step 3. Mount the Antenna	25
Figure 20. Mast Mount Antenna	26
Figure 21. Mast Mount Antenna	26
Figure 22. Magnetic Mount Bracket with Antenna – Mounted on Steel Surface	27
Figure 23. Highest RF signal when antennas are as parallel to each other as possible	27
Figure 24. Tapes applied to an antenna location (as shown on a WGLA Series Switch)	29
Figure 25. Limitless™ WOI dimensions	31
Figure 26. Limitless™ WOI with button options	31
Figure 27. Limitless™ WOI Battery Replacement	33
Figure 28. Limitless™ WPMM with call-outs	36
Figure 29. Limitless™ WDRR with call-outs	40

List of Tables

Table 1 – Table of Abbreviations and Definitions	2
Table 2 – Table Symbol Definitions	3
Table 3 – North America; Country Use Code “A”	4
Table 4 – Asia Pacific; Country Use Code “B”	4
Table 5 – European Union; Country Use Code “B”	4
Table 6 – Other European Countries; Country Use Code “B”	4
Table 7 – Approvals and Ratings	5
Table 8 – Radio Module Specifications	5
Table 9 – Electrical Specifications	5
Table 10 – Environmental Specifications	6
Table 11 – Country Use Code A Antenna Options	9
Table 12 – Country Use Code B Antenna Options	10
Table 13 – Antenna Options	20

1 DESCRIPTION

1.1 General

The Limitless™ product line combines the best of MICRO SWITCH™ products with the latest commercial off-the-shelf wireless technology. A wireless-enabled switch from the Wireless Operator Interface (WOI) series can now be used as a way for an operator to provide indication via a pushbutton or other type of operator. The WOI Series is especially beneficial for remote monitoring applications where wiring or wire maintenance is not physically possible or economically feasible. Combining this greater flexibility with proven harsh duty packaging can result in increased efficiencies and ease in establishing a remote operator for use in a variety of applications. This document will provide installation instructions to properly install a Limitless™ Wireless Operator Interface switch, WOI Switch or simply the WOI.

1.2 Principle of Operation

The WOI will transmit the position of its actuator (i.e. pushbutton) to a Limitless™ Wireless Panel Mount Monitor (WPMM Series) or Wireless DIN Rail Receiver (WDRR). The WPMM and WDRR will then indicate the actuator position of the WOI switch via a visual indicator, audible indicator and/or electronic output. The WOI supports no electrical signal inputs and is powered by a replaceable battery.

1.3 Model Reference

WOI	1	A	00	A	PA	G	
Module type	GEN code	RF code	Antenna type code	Country use code	Actuator type	Actuator color	Specials
WOI Series Operator Interface	1 Version 1	A 2.4 GHz; IEEE 802.15.4	00 No antenna; RP-SMA connector jack	A US, Canada, Mexico	None; open hole in enclosure	None	
			02 2.2 dBi omni w/switch mount; til/swivel	B All other approved countries ^{1,2}	PA Pushbutton only 22 mm round flush button, momentary	B Black	
			11 0 dBi omni w/ switch mount, str. design	¹ Some countries require specific communication certifications. Contact Honeywell for existing certification information.	PB Pushbutton only ³ 29 mm mushroom head, momentary	G Green	
				² If Limitless™ devices are used on machinery that may be shipped globally, use Country Code "B".	PC Pushbutton only ³ 40 mm mushroom head, maintained/push-pull	R Red	
					³ There will be the following specific note on the "I" & "E" drawing: NOT AVAILABLE IN RED	Y Yellow	

1.4 Abbreviations and Definitions















Table 1 – Table of Abbreviations and Definitions

ACMA	Australian Communications and Media Authority
dB	DeciBel
dB_i	DeciBel Isotropic
dB_m	DeciBel above or below 1 milliwatt
DSSS	Direct Sequence Spread Spectrum
EIRP	Equivalent isotropic radiated power
EMC	Electromagnetic Compatibility
ETSI	European Telecommunications Standards Institute
EU	European Union
FCC	Federal Communications Committee
ft-lbs	Foot-pounds
GHz	GigaHertz
IC	Industry Canada
ICES	Industry Canada Electrical Specification
IEEE	Institute of Electrical and Electronics Engineers
kbps	KiloBits Per Second
LED	Light Emitting Diode
Mhz	MegaHertz
MPE	Maximum Permissible Exposure
NA	North America – United States of America and Canada
NEMA	National Electrical Manufacturers Association
R&TTE	Radio and Telecommunications Terminal Equipment
RP-SMA	Reverse Polarity SMA connector
RF	Radio Frequency
TX	Transmit
WOI	Wireless Operator Interface
WLS	Wireless Heavy Duty Limit Switch Series
WPMM	Wireless Panel Mount Monitor Series

1.5 Symbol Definitions

The following table lists those symbols used in this document to denote certain conditions.

Table 2 – Table Symbol Definitions

Symbol	Definition
	ATTENTION: Identifies information that requires special consideration.
	TIP: Identifies advice or hints for the user, often in terms of performing a task.
CAUTION	Indicates a situation which, if not avoided, may result in equipment or work (data) on the system being damaged or lost, or may result in the inability to properly operate the process.
	CAUTION: Indicates a potentially hazardous situation which, if not avoided, may result in minor or moderate injury. It may also be used to alert against unsafe practices.
	CAUTION symbol on the equipment refers the user to the product manual for additional information. The symbol appears next to required information in the manual.
	WARNING: Indicates a potentially hazardous situation, which, if not avoided, could result in serious injury or death.
	WARNING symbol on the equipment refers the user to the product manual for additional information. The symbol appears next to required information in the manual.
	WARNING, Risk of electrical shock: Potential shock hazard where HAZARDOUS LIVE voltages greater than 30 Vrms, 42.4 Vpeak, or 60 Vdc may be accessible.
	ESD HAZARD: Danger of an electro-static discharge to which equipment may be sensitive. Observe precautions for handling electrostatic sensitive devices.
	Protective Earth (PE) terminal: Provided for connection of the protective earth (green or green/yellow) supply system conductor.
	Functional earth terminal: Used for non-safety purposes such as noise immunity improvement. NOTE: This connection shall be bonded to Protective Earth at the source of supply in accordance with national local electrical code requirements.
	Earth Ground: Functional earth connection. NOTE: This connection shall be bonded to Protective Earth at the source of supply in accordance with national and local electrical code requirements.
	Chassis Ground: Identifies a connection to the chassis or frame of the equipment shall be bonded to Protective Earth at the source of supply in accordance with national and local electrical code requirements.
	C-Tick Mark. The C-Tick Mark is a certification trade mark registered to ACMA (Australian Communications and Media Authority) in Australia under the Trade Marks Act 1995 and to RSM in New Zealand under section 47 of the NZ Trade Marks Act. The mark is only to be used in accordance with conditions laid down by ACMA and RSM. This mark is equal to the CE Mark used in the European Union.
	Notified Body. For radio equipment used in the European Union in accordance with the R&TTE Directive, the CE Mark and the notified body (NB) identification number is used when the NB is involved in the conformity assessment procedure. The alert sign must be used when a restriction on use (output power limit by a country at certain frequencies) applies to the equipment and must follow the CE marking.

2 SPECIFICATIONS

2.1 Intended Country Usage

Table 3 – North America; Country Use Code “A”

Country	ISO 3166 2 letter code
UNITED STATES	US
CANADA	CA

Table 4 – Asia Pacific; Country Use Code “B”

Country	ISO 3166 2 letter code
AUSTRALIA	AU
NEW ZEALAND	NZ

Table 5 – European Union; Country Use Code “B”

Country	ISO 3166 2 letter code	Country	ISO 3166 2 letter code
Austria	AT	Latvia	LV
Belgium	BE	Lithuania	LT
Bulgaria	BG	Luxembourg	LU
Cyprus	CY	Malta	MT
Czech Republic	CZ	Netherlands	NL
Denmark	DK	Poland	PL
Estonia	EE	Portugal	PT
Finland	FI	Romania	RO
France	FR	Slovak Republic	SK
Germany	DE	Slovenia	SI
Greece	GR	Spain	ES
Hungary	HU	Sweden	SE
Ireland	IE	United Kingdom	BG
Italy	IT		

Table 6 – Other European Countries; Country Use Code “B”

Country	ISO 3166 2 letter code	Country	ISO 3166 2 letter code
Bosnia and Herzegovina	BA	Norway	NO
Croatia	HR	Russian Federation	RU
Iceland	IS	Serbia	RS
Liechtenstein	LI	Switzerland	CH
Macedonia	MK	Turkey	TR

2.2 Certification and Approvals

See the product label for applicable approvals and ratings.

Table 7 – Approvals and Ratings

Approval/Item	Ratings/Description
Enclosure Type	IP65
Federal Communications Commission (FCC)	FCC Part 15.247
Industry Canada (IC)	Canadian ICES-003
European Telecommunications Standards Institute (ETSI)	CE mark
Australian Communications and Media Authority (ACMA)	C-Tick mark

2.3 Radio Module Specifications

Table 8 – Radio Module Specifications

Item	Specification
Wireless standard	WPAN IEEE 802.15.4 Direct Sequence Spread Spectrum (DSSS), 2.4 GHz
Data rate	250 kbps
Operating frequency	ISM 2.4 GHz
Module transmit power (max.)	22 dBm; Country Use Code “A” 8 dBm; Country Use Code “B”
Receive sensitivity (typ.)	-100 dBm

⚠ WARNING

The WOI must be installed in accordance with the requirements specified in this document. See Section 3 as only the specified antenna and cable types as outlined in this section are valid for WOI Series installations.

2.4 Electrical Specifications

Table 9 – Electrical Specifications

Item	Specification
Battery	3.6 Vdc Lithium Thionyl Chloride; 2/3AA size; Manufacturer: Uniwell, P/N DEV-10-0009 or Green Energy, P/N ER14335M

2.5 EMC Specifications

The latest applicable EMC Standards are as follows:

- EN 300 328, V1.7.1
- EN 61326-1 (2006)
- EN 301 489-1, V1.8.1
- EN 301 489-17, V2.1.1

2.6 Environmental Specifications

Table 10 – Environmental Specifications

Item	Specification
Operating temperature	-25 °C to 50 °C [-13 °F to 122 °F]
Storage temperature	-25 °C to 50 °C [-13 °F to 122 °F]
Operating humidity	0 %RH to 100 %RH

2.7 Agency Compliance Information

2.7.1 FCC Compliance Statements

- This device complies with Part 15 of FCC Rules and Regulations. Operation is subject to the following two conditions: (1) This device may not cause harmful interference and (2) this device must accept any interference received, including interference that may cause undesired operation.
- This equipment has been tested and found to comply with the limits for a Class B digital device, pursuant to Part 15 of the FCC Rules. These limits are designed to provide reasonable protection against harmful interference in a residential installation. This equipment generates, uses, and can radiate radio frequency energy and, if not installed and used in accordance with these instructions, may cause harmful interference to radio communications. Operation of this equipment in a residential area is likely to cause harmful interference in which case the user will be required to correct the interference at his/her own expense.
- Intentional or unintentional changes or modifications must not be made to the WOI unless under the express consent of the party responsible for compliance. Any such modifications could void the user's authority to operate the equipment and will void the manufacturer's warranty.

2.7.2 IC Compliance Statements

- To reduce potential radio interference to other users, the antenna type and its gain should be chosen so that the equivalent isotropic radiated power (EIRP) is not more than that permitted for successful communication.
- Operation is subject to the following two conditions: (1) this device may not cause interference, and (2) this device must accept any interference, including interference that may cause undesired operation of the device.
- This Class B digital apparatus has been tested and found to comply with Canadian ICES-003.
- French: Cet appareil numérique de la classe B est conforme à la norme NMB-003 du Canada.

2.7.3 Radio Frequency (RF) Safety Statement (FCC & IC)

To comply with FCC's and Industry Canada's RF exposure requirements, the following antenna installation and device operating configurations must be satisfied.

- Remote antenna for this unit must be fixed and mounted on outdoor permanent structures with a separation distance between any other antenna(s) of greater than 20cm and a separation distance of at least 20 cm [7.87 in] from all persons.
- Furthermore, when using an integral antenna with the WOI, it must not be co-located with any other antenna or transmitter device and have a separation distance of at least 20 cm [7.87 in] from all persons.

2.7.4 European Restrictions

- Information regarding national restrictions can be found in document: ERC/REC 70-03 (Relating to the use of short-range devices including appendixes and annexes). Documentation may be found in the document database in the European Communication's office.
- <http://www.erodocdb.dk/doks/dochistory.aspx?docintid=1622>

2.8 European (CE) Declaration of Conformity (DoC)

2.8.1 European Declaration of Conformity Statements

This section contains the European Declaration of Conformity (DoC) statement for the radio used in the Limitless™ WOI switch.

Figure 1. European Declaration of Conformity (DoC)

Honeywell

Honeywell Control Systems Ltd.,
Newhouse Industrial Estate,
Motherwell, Lanarkshire, ML1 5SB,
Scotland, United Kingdom.

Tel.: +44 (0)1698 481000
Fax: +44 (0)1698 481011

A subsidiary of Honeywell Control Systems Ltd.,
Registered Office: Honeywell House,
Arlington Business Park,
Bracknell, Berkshire,
R12 1EB,
Registered No 217808 (England)

EC Declaration of Conformity

Honeywell Control Systems Ltd. hereby declare that the products identified below conform to the essential requirements of the EC Directive(s) listed below and that the products supplied are in conformity with the type described in any EC Type Examination Certificate (EC TEC) identified below.

Manufacturer: Honeywell International, MICRO SWITCH Division
11309 West Chetlain Lane, Galena, Illinois,
IL 61036-0327, USA

Product: WOI Series: Wireless Operator Interface

<u>Directive (Amendments)</u>	<u>Conformity Details</u>
2006/95/EEC	Standards applied: EN 61010-1: 2001
1999/5/EC and 2004/108/EC	Standards applied: EN 61326-1:2006 ETSI EN 300 328 V1.7.1 ETSI EN 301 489-1 V1.8.1 and -17 V2.1.1

Signed on behalf of Honeywell Control Systems Ltd. : 
Frank Turnbull, S&C Chief Engineer

DoC No: A457 DoC Issue: 1 DoC Date: 12/06/2012 Page 1 of 2

2.8.2 For more information about the R&TTE Directive

The following website contains additional information about the Radio and Telecommunications Terminal Equipment (R&TTE) directive:
<http://ec.europa.eu/enterprise/sectors/rtte/faq/>

3 ANTENNA OPTIONS ALLOWED PER COUNTRY USE CODE

This section defines the antenna options that can be used in a particular country of interest; reference Section 2.1 for a list of Countries per Country Use Code. It is important to determine the country the WOI switch will be used in. Thereby, noting the correct Country Use Code in the WOI nomenclature will help ensure proper selection of antenna and/or cable options. The integral antenna mounts directly to the WOI RP-SMA jack while the remote antenna mounts to the WOI RP-SMA jack via a cable assembly. Further technical information on the WAN Series antennas, WAMM Series magnetic mounts and WCA Series cable assemblies can be found in Section 5.

⚠ WARNING

The WOI must be installed in accordance with the requirements specified in this document in order to comply with the specific Country Communication Agency requirements. (i.e. FCC, IC, ETSI, ACMA, etc.) See Section 2 as it requires choosing the correct Country Use Code and thus allowable antenna and/or cable usage.

3.1 COUNTRY USE CODE “A” ANTENNA OPTIONS

Table 11 – Country Use Code A Antenna Options

COUNTRY CODE A (Note: all columns are independent of each other)					
Antenna Type Code (allowed for use)	Integral Mount Antennas (allowed for use)	Remote Mount Antennas (allowed for use)	Magnetic Remote Mount Assemblies/Antennas WAMM100RSP-005 WAMM100RSP-010 (allowed for use)	Extension Cable Assemblies/Antennas for Remote Mount WCA200RSJRSP-002 WCA200RSJRSP-005 WCA200RSJRSP-010 WCA200RSJRSP-015 WCA200RSJRSP-020 (allowed for use)	Extension Cable Assemblies/Antennas for Remote Mount WCA200RNPRSP-002 WCA200RNPRSP-010 (allowed for use)
00	WAN01RSP	WAN03RSP	WAN01RSP	WAN01RSP	WAN06RNJ
01	WAN02RSP	WAN06RNJ	WAN02RSP	WAN02RSP	
02	WAN04RSP	WAN09RSP	WAN04RSP	WAN03RSP	
03	WAN05RSP	WAN10RSP	WAN05RSP	WAN04RSP	
04	WAN07RSP	WAN11RSP	WAN07RSP	WAN05RSP	
05	WAN08RSP		WAN08RSP	WAN07RSP	
06				WAN08RSP	
07				WAN09RSP	
08				WAN10RSP	
09				WAN11RSP	
10					
11					

Integral mount: Antennas have an RP-SMA plug that connects directly to the WOI RP-SMA jack

Remote mount: Remote mount antenna uses a cable with a RP-SMA plug that connects directly to the WOI RP-SMA jack

3.2 COUNTRY USE CODE “B” ANTENNA OPTIONS

Table 12 – Country Use Code B Antenna Options

COUNTRY CODE B (Note: all columns are independent of each other)					
Antenna Type Code (allowed for use)	Integral Mount Antennas (allowed for use)	Remote Mount Antennas (allowed for use)	Magnetic Remote Mount Assemblies/Antennas WAMM100RSP-005 WAMM100RSP-010 (allowed for use)	Extension Cable Assemblies/Antennas for Remote Mount WCA200RSJRSP-002 WCA200RSJRSP-005 WCA200RSJRSP-010 WCA200RSJRSP-015 WCA200RSJRSP-020 (allowed for use)	Extension Cable Assemblies/Antennas for Remote Mount WCA200RNPRSP-002 WCA200RNPRSP-010 (allowed for use)
00	WAN01RSP	WAN03RSP	WAN01RSP	WAN01RSP	WAN01RSP
01	WAN02RSP	WAN09RSP	WAN02RSP	WAN02RSP	WAN02RSP
02	WAN07RSP	WAN10RSP	WAN07RSP	WAN04RSP	WAN03RSP
03	WAN08RSP		WAN08RSP	WAN07RSP	WAN07RSP
05				WAN08RSP	WAN08RSP
10					WAN09RSP
11					WAN10RSP
					WAN11RSP

Integral mount: Antennas have an RP-SMA plug that connects directly to the WOI RP-SMA jack

Remote mount: Remote mount antenna uses a cable with a RP-SMA plug that connects directly to the WOI RP-SMA jack

ATTENTION

If using the WOI in a portable application (for example, the WOI is used in a handheld device and the antenna is less than 20 cm from the human body when the device is in operation): The integrator is responsible for passing additional SAR (Specific Absorption Rate) testing based on FCC rules 2.1091 and FCC Guidelines for Human Exposure to Radio Frequency Electromagnetic Fields, OET Bulletin and Supplement C. The testing results will be submitted to the FCC for approval prior to selling the integrated unit. The required SAR testing measures emissions from the module and how they affect the person.

ATTENTION

The antenna cables should not be modified (i.e. cut short and/or re-terminated) as it may affect Communication Agency approval.

Notes for Section 3.1& 3.2 • Tables 11 and 12:

1. Antennas listed in this chart are approved for use with the Digi International XBee –PRO® RF Module which the WOI utilizes.
2. Industry Canada Compliance Statement: This device has been designed to operate with the antenna types listed in this document, and having a maximum gain of 9 dBi. Antenna types not included in this list or having a gain greater than 9 dBi are strictly prohibited for use with this device. The required antenna impedance is 50 Ohm.

4 QUICK START UP

4.1 Antenna Connection

⚠ WARNING

RF EXPOSURE

To satisfy FCC RF exposure requirements for mobile transmitting devices, a separation distance of 20 cm [7.87 in] or more should be maintained between the antenna of this device and persons during device operation. To ensure compliance, operation at closer than this distance is not recommended. The antenna used for this transmission must not be co-located in conjunction with any other antenna or transmitter.

Failure to comply with these instructions could result in death or serious injury.

CAUTION

Power to the WOI should not be applied (ensure battery is removed) during installation of antenna as damage could occur to the WOI electronics.

The antenna and antenna guard are packaged separately and thus will need to be assembled to the WOI.

A **direct mount antenna** (either straight or tilt & swivel) can be easily mounted by threading the mating RP-SMA plug of the antenna to the RP-SMA jack on the WOI. Tighten the connection until finger tight. Then attach the antenna guard by simply threading the guard finger tight onto the threaded base with the RP-SMA connector.

A **remote mount antenna** requires the use of an extension cable to allow the antenna to be mounted in a different location than the WOI location. The extension cable will need to have one end with a RP-SMA plug connector which will mate with the WOI connector jack under the same mounting procedure as the direct mount antenna. The other end of the extension cable will need to mate with antenna connector directly or it may be integral to the particular remote mount antenna chosen.

Limitless™ WOI RP-SMA Connection, Integral



Limitless™ WOI RP-SMA Connection, Remote



4.2 End User Switch Connection (if applicable)

A WOI Series switch can be ordered without an actuator type (or switch) and thus the end user will need to mount and electrically connect the 22mm switch that they have chosen to the WOI device.

Mounting: The mounting hole and enclosure are designed to fit most 22 mm industrial switches that are in the market place. The dimensions are depicted in Figure 2 and installation of the switch should be conducted in accordance to the chosen switch manufacturer's requirements.

Figure 2. Limitless™ WOI Mounting Hole Dimensions

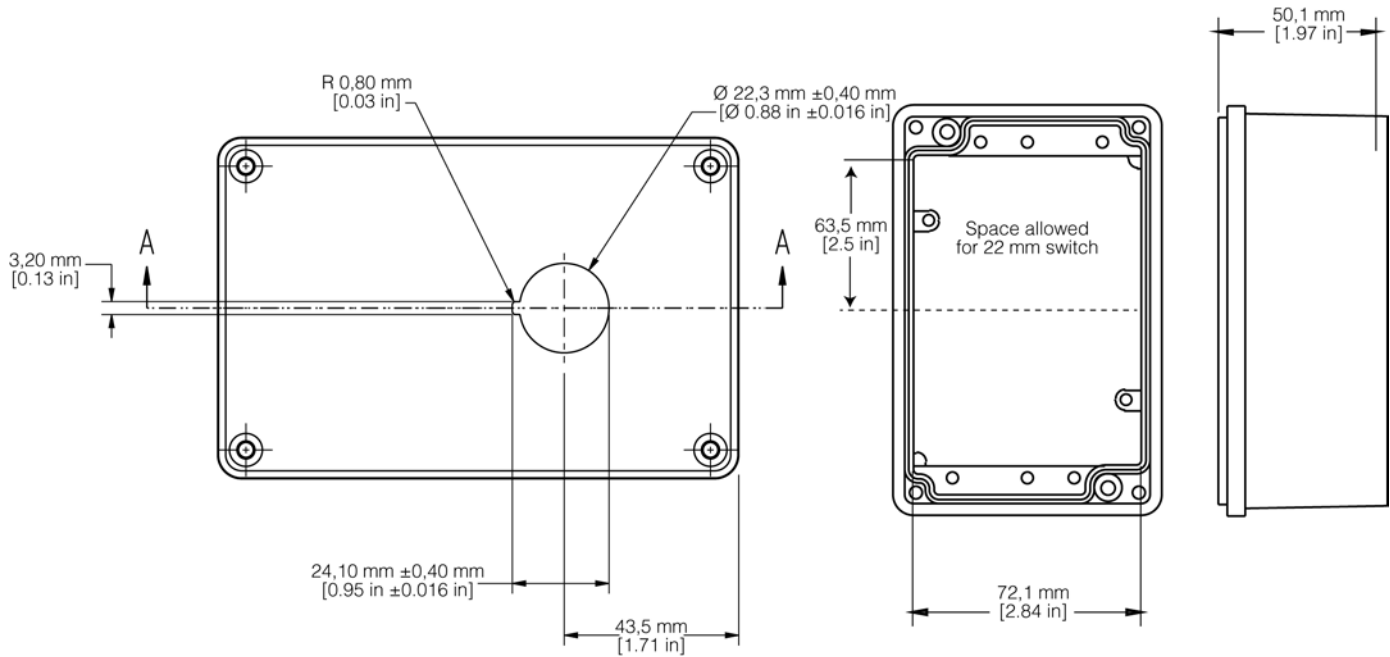

Electrical connections: The requirement of the 22 mm switch design is to have a Normally Open (NO) and Normally Closed (NC) contact block with gold contacts capable of reliably controlling a 30 mA @ 3.6 Vdc electrical load. The following is the required wire color connection (see Figure 3). Contact block shown is an example and not supplied by Honeywell when the end user supplies their own 22 mm operator/switch.

BROWN wire: Connect one brown wire to the NO terminal and the other brown wire to the NC terminal ①

BLACK wire: Connect to the other terminal of the NO contact block ②

BLUE wire: Connect to the other terminal of the NC contact block ③

Figure 3. Limitless™ WOI leadwires

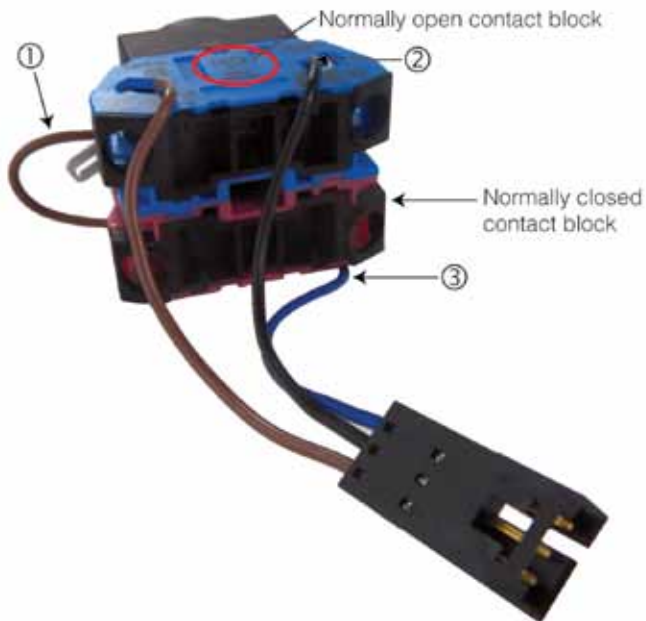

4.3 Battery Connection Procedure

⚠ WARNING

RISK OF DEATH OR SERIOUS INJURY FROM EXPLOSION OR FIRE

Connection and disconnection of the batteries should only be performed in a non-hazardous area. The batteries used in this device may present a risk of fire or chemical burn if mistreated. Do not recharge, disassemble, heat above 100 °C [212 °F], or incinerate.

Failure to comply with these instructions could result in death or serious injury.

⚠ WARNING

RISK OF DEATH OR SERIOUS INJURY FROM EXPLOSION OR FIRE

If WOI is to be returned to Honeywell for any reason, the battery **MUST** be removed prior to shipping. Dispose of used batteries promptly per local regulations or the battery manufacturer's recommendations. Keep away from children. Do not disassemble and do not dispose of in fire.

Failure to comply with these instructions could result in death or serious injury.

STOP ATTENTION

RISK OF DEATH OR SERIOUS INJURY FROM EXPLOSION OR FIRE

Use only the following 3.6V lithium thionyl chloride (Li-SOCl₂) battery (non-rechargeable), size 2/3AA. No other batteries are approved for use in the WOI Series.

- Uniwell, DEV-10-0009
- Green Energy, ER14335M
- Honeywell, WBT1

WOI battery activation (see Figures 4 and 5):

Tools required: Slotted or Phillips screwdriver

Step	Action
1	If applicable, remove the four screws ① on the housing cover.
2	Using a finger, press down slightly on the battery top ② and remove the battery insulator ③. Insure that the battery is properly seated and making good contact.
3	Replace cover and retighten screws or immediately proceed to Section 4.4 Pairing Mode.

Figure 4. Limitless™ WOI Housing



Figure 5. Limitless™ WOI Battery and Insulator



4.4 Pairing Mode

Pairing is required to initiate and establish an RF communication link between each single WOI and a single WPMM or WDRR. The WOI will be shipped from the factory with two identification labels ⑩ that are recommended to be completed and applied to the WOI housing during the pairing mode. As there are up to 16 WOIs that can be paired to a single WPMM or 14 WOIs to a WDRR, these labels will be used to identify the WOI switch in the Sequence of #1 up to #16 (up to 16 WOI may be paired to a single WPMM). The initial WOI switch paired to the WPMM or WDRR will be Sequence #1; the second WOI paired will be Sequence #2 and so on. If replacing a WOI switch that has been purged (see Purge Mode Section of the WPMM or WDRR Installation and Technical Manual), identify the correct replacement Sequence # on the identification labels.

Pairing steps when using a WPMM: The battery will need to be activated in the WOI and proper power applied to the WPMM (green ⑥ LED illuminated, Figure 7) before proceeding with this pairing procedure. Once the pairing is completed, the WOI selected will only communicate with the WPMM it was paired to and no other device. The following procedure does not indicate WPMM operation if the “set-up mode” in the WPMM was used (for example, set-up mode allows muting of the buzzer and output reversal. See Set-up Mode section in the WPMM Installation and Technical Manual for more information).

Step	Action
1	Completely read this procedure before starting in order to understand the timing of events that need to be performed.
2	WOI: Remove (if required) the four screws ① on the housing cover (See Figure 6) of the WOI and locate the function button ④ to be used in Step 4. (See Figure 8)
3	WPMM: Press the Function button ③ on WPMM (See Figure 7) for more than four seconds and less than eight seconds at which time the green ⑥ and yellow ⑦ LEDs will be flashing which indicates to release the function button immediately as it has entered the pairing mode.
4	WOI: Within a 30 second interval of Step 3, depress the WOI switch function button ④ (See Figure 8) and hold depressed for more than one second and less than 12 seconds at which time the orange ⑤ LED turns on. While in pairing mode, the orange led will flash on for 100 ms every second. The orange ⑤ LED flashes three times 100 ms on, 100 ms off when pairing succeeds. If pairing does not succeed, the orange ⑤ LED will turn off and user will need to repeat steps starting with Step 3.
5	WPMM: Successful pairing will be indicated by the green ⑥ and yellow ⑦ LEDs (See Figure 7) ceasing to flash and remaining on for a few seconds before turning off. A short buzzer beep will also occur.
6	To confirm proper pairing between the WOI and WPMM, actuate the WOI, and the red LED ⑧ should illuminate along with a buzzer sound.
7	Record the WOI Sequence # on identification labels ⑩ and apply to the WOI housing in desired locations (See Figure 9).
8	Repeat Steps 2-7 to add additional WOI switches. Up to 16 WOI can be paired to a single WPMM.

Figure 6. Limitless™ WOI Housing



Figure 8. Limitless™ WOI with Function Button Depressed

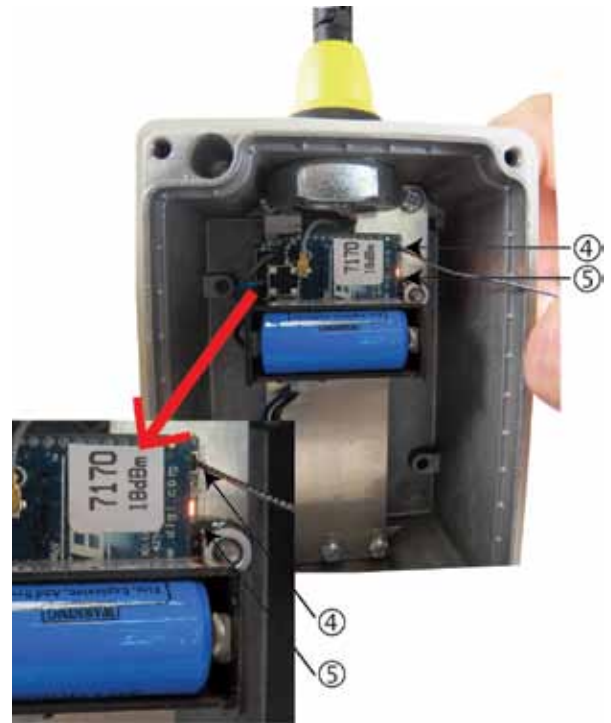

Figure 7. Limitless™ WPMM Housing



NOTE: Use a blunt object, such as a paper clip to actuate the function switch ④.

Figure 9. Limitless™ WOI Label Placement



Pairing Steps when using a WDRR (See Figure 10): The battery will need to be activated in the WOI and proper power applied to the WDRR (green LED ⑤ illuminated) before proceeding with this pairing procedure. Once the pairing is completed, the WOI selected will only communicate with the WDRR it was paired to and no other device.

The Limitless™ WOI is shipped from the factory with two identification labels ⑩ (see Figure 9) that are recommended to be completed and applied to the Limitless™ WOI housing during the pairing mode. As there are up to 14 Limitless™ inputs that can be paired to a single WDRR, these labels will be used to identify the Limitless™ switch in the sequence of #1 to #14. The initial Limitless™ input paired to the WDRR receiver will be Sequence #1 (corresponding to output #1); the second Limitless™ switch paired will be Sequence #2 (corresponding to output #2) and so on.

The battery will need to be activated in the WOI and proper power applied to the WDRR Series Receiver before proceeding with this pairing procedure. Once the pairing is completed, the WOI selected will only communicate with the WDRR receiver it was paired to and no other device. The following procedure does not indicate WDRR operation if the “set-up mode” in the WDRR was used (for example, set-up mode allows output reversal. See Set-up Mode section in the WDRR Installation and Technical Manual for more information).

Step	Action
1	Completely read this procedure before starting in order to understand the timing of events that need to be performed.
2	WOI: Remove (if required) the four screws ① on the housing cover (See Figure 6) of the WOI and locate the function button ④ to be used in Step 4. (see Figure 8)
3	WDRR: Press the Function button ⑩ on WDRR (See Figure 10) for more than four seconds and less than eight seconds at which time the green and yellow LEDs ⑥ (see Figure 10) will be flashing which indicates to release the function button immediately as it has entered the pairing mode.
4	WOI: Within a 30 second interval of Step 3, depress the WOI switch function button ④ (See Figure 8) and hold depressed for more than one second and less than 12 seconds at which time the orange ⑤ LED turns on. While in pairing mode, the orange led will flash on for 100 ms every second. The orange ⑤ LED flashes three times 100 ms on, 100 ms off when pairing succeeds. If pairing does not succeed, the orange ⑤ LED will turn off and user will need to repeat steps starting with Step 3.
5	WDRR Receiver: Successful pairing will be indicated by the green and yellow LEDs ⑥ (see Figure 10) ceasing to flash and remaining on for a few seconds before turning off. The specific Tricolor Output LED will also turn on.
6	To confirm proper pairing between the Limitless™ WOI and WDRR, actuate the WOI, and the Tricolor Output LED ⑥ (see Figure 10) should turn on to indicate the proper output status.
7	Record the WOI Sequence # on identification labels ⑩ and apply to the WOI housing in desired locations (See Figure 9).
8	Repeat Steps 2-7 to add additional Limitless™ switch. Up to 14 Limitless™ switches can be paired to a single WDRR.

Figure 10. Limitless™ WDRR Housing

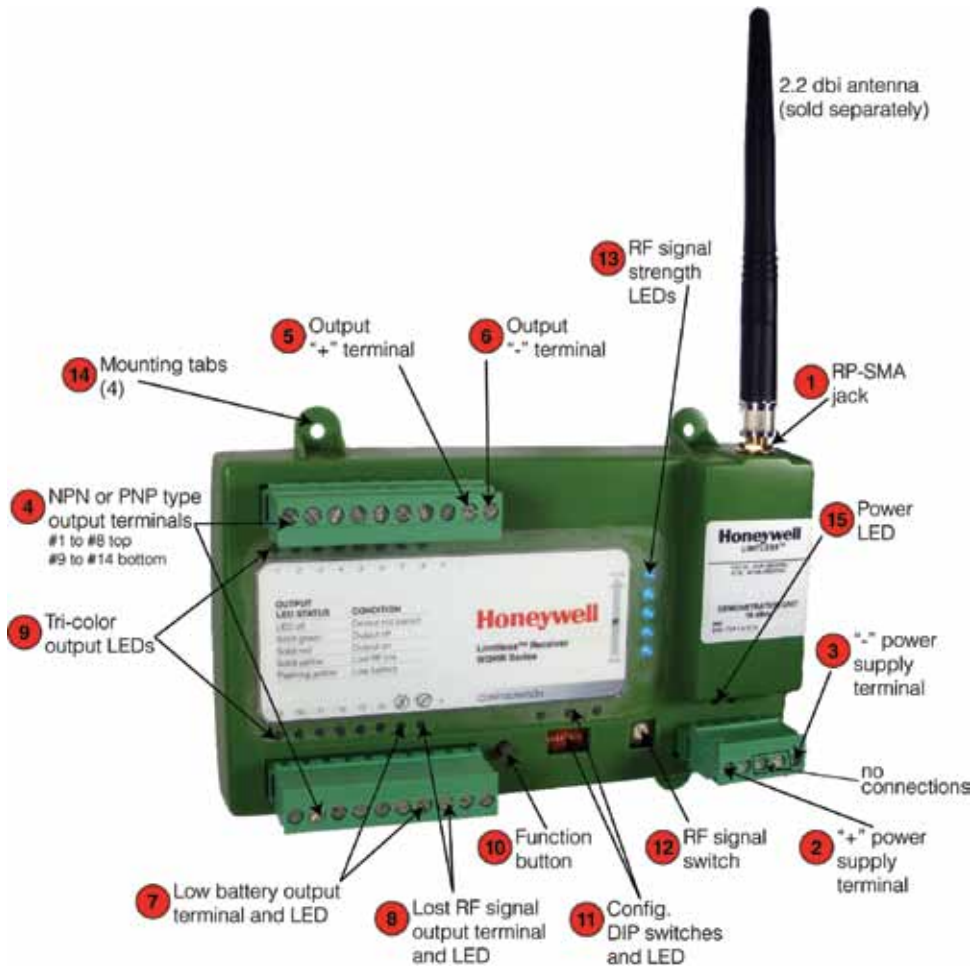

4.5 WOI Purge Mode

The purging of a WOI is required when a previously paired WOI is desired to be paired again per Section 4.4. Follow the procedure below which will then allow a new pairing to be conducted after successful purging:

Step	Action
1	Remove (if required) the four screws ① on the housing cover of the WOI (See Figure 6) and locate the switch function button ④ & orange LED ⑤ (See Figure 8).
2	Press and hold the switch function button for greater than 12 seconds. Initially the orange LED ⑤ turns on and after the 12 seconds will turn off indicating the WOI has been purged (see Figure 8).
3	Repeat above steps if necessary to purge more Limitless™ WOIs.

4.6 WPMM/WDRR Operation and LED functions

4.6.1 Principle of Operation of the WPMM and Limitless™ WOI Switch :

A Limitless™ WOI switch will send an RF signal to the WPMM when the actuator (i.e. pushbutton) of the switch changes position. There are up to 16 WOI switches that will communicate and indicate their actuation position with a single WPMM. The actuation of any one of the WOI switches will cause a single red output LED to illuminate, a buzzer to sound, and/or a change in the electrical output. However, there will be no differentiation of outputs (visual, audible or electrical state change) between the WOI switches (up to 16) being actuated. Further, if a WOI's switch is actuated and thus causes the single red output LED to illuminate, a buzzer to sound, and/or a change in the electrical output, actuation of another WOI switch(s) will not cause another output change (visual, audible and/or electrical state change).

The operation and LED functions for the WPMM are visually depicted and described in the WPMM Installation and Technical Manual located at www.honeywell.com/limitless.

4.6.2 WDRR Operation and LED functions

A Limitless™ WOI switch will send an RF signal to the WDRR when the actuator (i.e. pushbutton) of the switch changes position. There are up to 14 WOI switches that will communicate and indicate their actuation position with a single WDRR. The actuation of any one of the WOI switches will cause a single red output LED to illuminate and change in the electrical output for the associated output (#1 thru 14) that it is paired too.

The operation and LED functions for the WDRR are visually depicted and described in the WDRR Installation and Technical Manual located at www.honeywell.com/limitless.

5 ANTENNA CONSIDERATIONS/OPTIONS & SWITCH/ANTENNA INSTALLATION

5.1 Overview of Antenna Options

The following chart lists the antenna options along with the various characteristics that will be referenced throughout this section. This section is intended to assist an end user in determining which antenna(s) are worth investigating and subjecting to application requirements for proof of suitability.

Table 13 – Antenna Options

Ant. type code*	Repl. ant.	Replacement antenna mount or cable	Ant. gain (max.)	Design/style	Mount	Cable length	Environment usage **	Antenna material	Cable material/type	Mount material
01	WAN01RSP	N/A	2.2 dBi	Omni/Straight	Integral	N/A	Indoor or outdoor use	UV stable LG Keyflex BT-1040D	N/A	N/A
02	WAN02RSP	N/A	2.2 dBi	Omni / Tilt and Swivel	Integral	N/A	Indoor or outdoor use	UV stable LG Keyflex BT-1040D	N/A	N/A
03	WAN03RSP	N/A	3.0 dBi	Omni/ Flat	Remote w/ adhesive mount	2.99 m [9.8 ft]	Indoor or outdoor use	UV stable ABS	UV stable PVC/ RG-174 coax	N/A
04	WAN04RSP	WAMM100RSP-005	5.5 dBi	Omni / Tilt and Swivel	Remote with magnetic mount	1.52 m [5 ft]	Indoor or limited outdoor exposure. Protect against direct rain, salt, snow, ice	UV stable Molded Polyurethane	UV stable PVC/ RG-174 coax	UV stable black ABS
05	WAN04RSP	WAMM100RSP-010	5.5 dBi	Omni / Tilt and Swivel	Remote with magnetic mount	3.04 m [10 ft]	Indoor or limited outdoor exposure. Protect against direct rain, salt, snow, ice	UV stable Molded Polyurethane	UV stable PVC/ RG-174 coax	UV stable black ABS
06	WAN05RSP	WAMM100RSP-005	9.0 dBi	Omni / Tilt and Swivel	Remote with magnetic mount	1.52 m [5 ft]	Indoor or limited outdoor exposure. Protect against direct rain, salt, snow, ice	UV stable Molded Polyurethane	UV stable PVC/ RG-174 coax	UV stable black ABS
07	WAN05RSP	WAMM100RSP-010	9.0 dBi	Omni / Tilt and Swivel	Remote with magnetic mount	3.04 m [10 ft]	Indoor or limited outdoor exposure. Protect against direct rain, salt, snow, ice	UV stable Molded Polyurethane	UV stable PVC/ RG-174 coax	UV stable black ABS
08	WAN06RSP	WCA200RNPRSP-002	8.0 dBi	Omni/Straight	Remote with mast mount	0.91 m [3 ft]	Indoor or outdoor use	UV stable fiberglass	UV stable PVC/RG-316 coax, UV stable Polyethylene/200 Series coax	300 series SST aluminum alloy
09	WAN06RSP	WCA200RNPRSP-010	8.0 dBi	Omni/Straight	Remote with mast mount	3.35 m [11 ft]	Indoor or outdoor use	UV stable fiberglass	UV stable PVC/RG-316 coax, UV stable Polyethylene/200 Series coax	300 series SST aluminum alloy
10	WAN01RSP	WAMM100RSP-010	2.2 dBi	Omni/Straight	Remote w/ magnetic mount	3.04 m [10 ft]	Indoor or limited outdoor exposure. Protect against direct rain, salt, snow, ice	UV stable LG Keyflex BT-1040D	UV stable PVC/ RG-174 coax	UV stable black ABS
11	WAN07RSP	N/A	0 dBi	Omni/Straight	Integral	N/A	Indoor or outdoor use	UV stable	N/A	N/A
n/a	WAN08RSP	N/A	0 dBi	Omni/90°	Integral	N/A	Indoor or outdoor use	UV stable	N/A	N/A
n/a	WAN09RSP	N/A	3.0 dBi	Omni/Low profile straight	Remote w/ magnetic mount	4.57 m [15 ft]	Indoor or outdoor use	UV stable ABS plastic	UV stable Black PVC	Nickel plated steel
n/a	WAN10RSP	N/A	5.0 dBi	Omni/Straight	Remote w/ magnetic mount	4.57 m [15 ft]	Indoor or outdoor use	Nickel Plated Steel	UV stable Black PVC	Nickel plated steel
n/a	WAN11RSP	N/A	4.0 dBi	Omni/Low profile dome	Remote w/ mobile thru-hole screw mount	4.57 m [15 ft]	Indoor or outdoor use	UV stable Black PVC	UV stable Black PVC	Nickel plated steel

*Reference Limitless™ Nomenclature (i.e. WPMM Series, WLS Series, etc.); Section 1.3 for the WOI Series

**Reference Limitless™ Environment Usage section 5.5 for further details

STOP ATTENTION
 The antenna cables should not be modified (i.e. cut short and/or re-terminated) as it may affect Communication Agency approval.

WARNING
 The WOI must be installed in accordance with the requirements specified in this document. See Section 3 as only the specified antenna and cable types as outlined in this section are valid for WOI Series installations.

5.1.1 Omni-directional Antenna Design

The omni-directional antennas offered in the Limitless™ Series were chosen for their ability to be used in applications where transmit-and-receiver antennas may be moving with respect to each other or could also be stationary. They are dipole antennas that radiate power (power from the internal radio of the WLS switch) in a 360° outward pattern in a plane perpendicular to the length of the antenna element. “Omni” may suggest the antenna radiates power in all directions, but that is not the case. The actual antenna radiation pattern looks more like a toroid (doughnut-shape) as shown in Figure 11.

Figure 11. Radiation Pattern of an Omni-directional Antenna

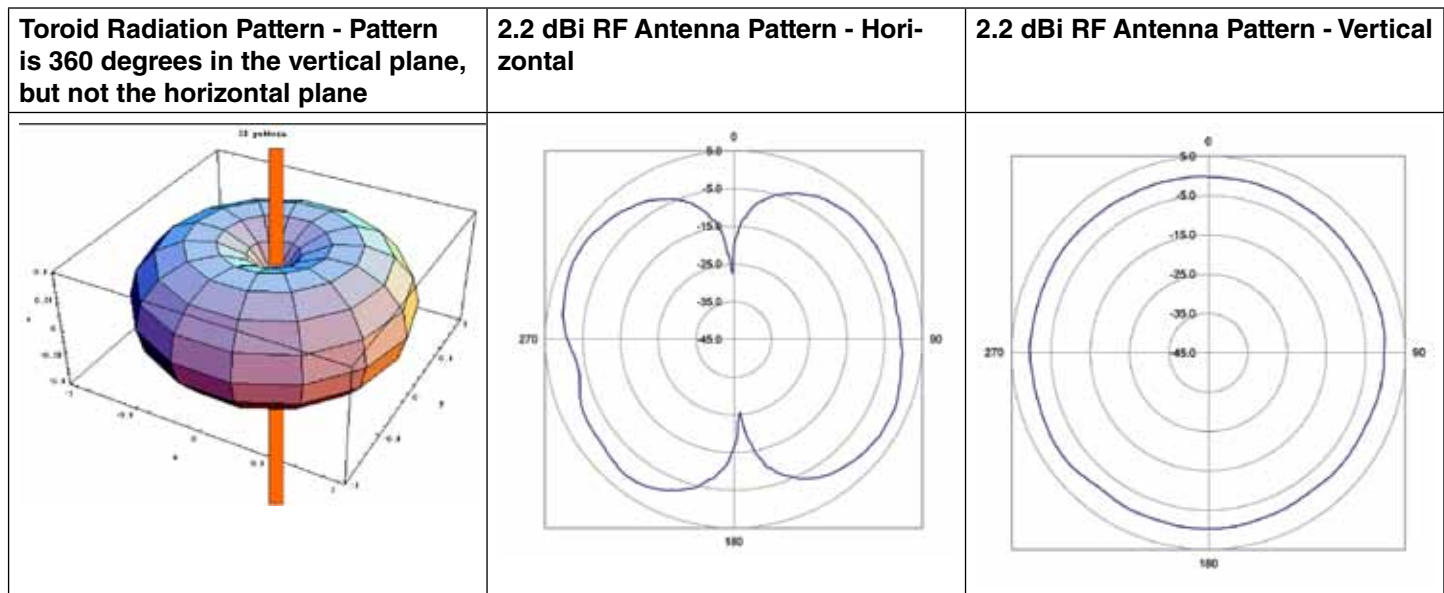

The antenna radiates virtually zero power in the Z axis and most of the power in the X and Y axis. Increasing the antenna’s gain will increase the power only in the X and Y axis. As a result, the radiation pattern becomes narrower. For instance, this is analogous to the reflector in an automobile’s headlight. The reflector does not add light or increase the luminous intensity of the light bulb, rather it simply directs all the light energy in the forward direction where the light is needed most.

5.2 Antenna Mounting and Considerations

5.2.1 Antenna Mounting Location with Respect to RF Signal

⚠ WARNING

RF EXPOSURE

To satisfy FCC RF exposure requirements for mobile transmitting devices, a separation distance of 20 cm [7.87 in] or more should be maintained between the antenna of this device and persons during device operation. To ensure compliance, operation at closer than this distance is not recommended. The antenna used for this transmission must not be co-located in conjunction with any other antenna or transmitter.

Failure to comply with these instructions could result in death or serious injury.

There are several environmental factors to consider with respect to antenna location during installation. These factors can affect the radio frequency (RF) signal strength being both transmitted and received by the WOI switch and corresponding WPMM monitor or WDRR receiver. It is desirable for the antenna to be mounted to limit exposure of adjacent materials/objects between the Limitless™ WOI and WPMM or WDRR receiver, as they will have an effect on RF signal strength. If the mounting location for an omni-directional antenna is on the side of a building or tower, the antenna pattern will be degraded on the building or tower side.

Obstacles that affect antenna patterns and RF signal strength:

- Indoor: Concrete, wood, drywall, and metal walls, etc.
- Outdoor: Vehicles, buildings, trees, structures, topology, weather conditions, chain link fence, major power cables, etc.

Best performance is achieved when antennas for both the WOI switch and WPMM monitor or WDRR receiver are mounted at the same height and in a direct line of sight (LOS) with no obstructions. Generally, the higher the antenna is above ground, the better it performs. Another concern is RF interference, discussed in Section 5.5.3.

Figure 12. WOI to WPMM or WDRR Antennas with RF Signal Line of Sight (LOS) Free From Obstacles

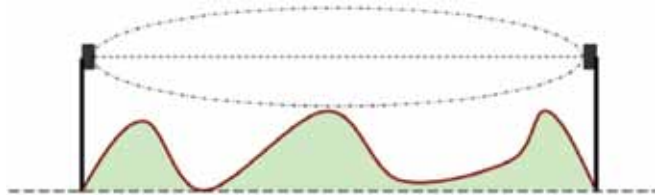
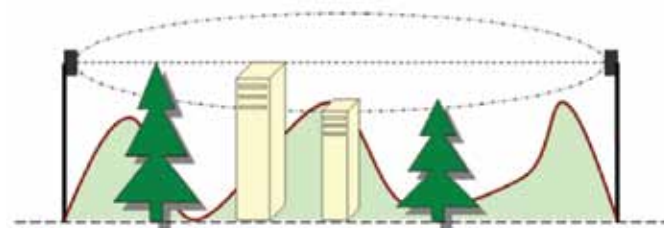

Figure 13. WOI to WPMM or WDRR Antennas with RF Signal Line of Sight (LOS) Affected by Obstacles



5.2.2 Outdoor Installation Warnings

⚠ WARNING

LIVES MAY BE AT RISK!

Carefully observe these instructions and any special instructions included with the equipment being installed.

⚠ WARNING

CONTACTING POWER LINES COULD BE FATAL

Look over the site before beginning any installation and anticipate possible hazards, especially these:

- Make sure no power lines are near where possible contact can be made. Antennas, masts, towers, guy wires, or cables may lean or fall and contact these lines. People may be injured or killed if they are touching or holding any part of equipment when it contacts electric lines. Make sure there is NO possibility that equipment or personnel can come in contact directly or indirectly with power lines.
- Assume all overhead lines are power lines.
- The horizontal distance from a tower, mast, or antenna to the nearest power line should be at least twice the total length of the mast/antenna combination. This will ensure that the mast will not contact power if it falls during either installation or later.

⚠ WARNING

TO AVOID FALLING, USE SAFE PROCEDURES WHEN WORKING AT HEIGHTS ABOVE GROUND

- Select equipment locations that will allow safe, simple equipment installation
- Don't work alone. A friend or co-worker can save a life if an accident happens.
- Use approved, non-conducting ladders and other safety equipment. Make sure all equipment is in good repair.
- If a tower or mast begins falling, don't attempt to catch it. Stand back and let it fall.
- If anything such as a wire or mast does come in contact with a power line, DON'T TOUCH IT OR ATTEMPT TO MOVE IT. Instead, save a life by calling the power company.
- Don't attempt to erect antennas or towers on windy days.

⚠ WARNING

MAKE SURE ALL TOWERS AND MASTS ARE SECURELY GROUNDED, AND ELECTRICAL CABLES CONNECTED TO ANTENNAS HAVE LIGHTNING ARRESTORS.

This will help prevent fire damage or human injury in case of lightning, static build up, or short circuit within equipment connected to antenna.

- The base of the antenna mast or tower must be connected directly to the building protective ground or to one-or-more approved grounding rods, using 1 AWG ground wire and corrosion-resistant connectors.
- Refer to the National Electrical Code for grounding details.
- Lightning arrestors for antenna feed coaxial cables are available from HyperLink Technologies, Inc.

⚠ WARNING

If a person comes in contact with electrical power, and cannot move
DO NOT TOUCH THAT PERSON OR RISK ELECTROCUTION.

- Use a non-conductive dry board, stick, or rope to push, pull, or drag them so they no longer are in contact with electrical power.
- Once they are no longer contacting electrical power, administer CPR if certified, and make sure emergency medical aid has been requested.

5.2.3 Antenna Connection, Styles, and Mounting Options

⚠ WARNING

RF EXPOSURE

To satisfy FCC RF exposure requirements for mobile transmitting devices, a separation distance of 20 cm [7.87 in] or more should be maintained between the antenna of this device and persons during device operation. To ensure compliance, operation at closer than this distance is not recommended. The antenna used for this transmission must not be co-located in conjunction with any other antenna or transmitter.

Failure to comply with these instructions could result in death or serious injury.

CAUTION

Power to the WOI switch should not be applied during installation of an antenna as damage could occur to the WOI switch electronics.

5.2.3.1 Antenna Connection, Styles, and Mounting Options

Physical connection of the antenna to the WOI switch is accomplished by using mating RP-SMA connectors: plug and jack. Integral-mount antennas have an RP-SMA plug that connects directly to the WOI RP-SMA jack. The remote mount antenna uses a cable with an RP-SMA plug that connects directly to the WOI RP-SMA jack allowing the antenna to be remotely mounted away from the WOI switch. Mounting options are based on user preference, communication agency approvals, WOI switch mounting location, and obstacles as discussed in Section 5.2.1.

An integral or remote mount antenna can be easily mounted by threading the mating RP-SMA plug of the antenna to the RP-SMA jack on the WOI switch. Reference section 5.5 for further details on extra environmental protection of RP-SMA connections. Tighten the RP-SMA connection until finger tight, and then attach the lime/black guard finger tight. See Figures 14 and 15.

Figure 14. Limitless™ WOI RP-SMA Connection, Integral



Figure 15. Limitless™ WOI RP-SMA Connection, Remote



5.2.3.2 Antenna Styles and Mounting Options

Choosing an antenna mounting style depends on application conditions, along with antenna benefits and/or features and user preference. The antenna's gain (discussed further in Section 5.4) to some extent determines physical size; also a consideration is the amount of room available in the application.

Straight or Tilt/Swivel: A benefit of the straight antenna is its rigid design and resistance to being repositioned (shock, vibration, wind, etc.) when compared to a tilt and swivel design. It is also more resistant to weather conditions as there's no swivel-joint connection for contaminants to enter. A benefit of the tilt & swivel design is that it allows easier positioning in relation to other antenna(s) to obtain a suitable RF signal.

Figure 16. Straight and Tilt/Swivel antennas



Adhesive mount: The benefit of the remote adhesive mount antenna is mounting flexibility to a number of surfaces and in various orientations. Remember, the surface that the antenna is being mounted to will affect the radiation pattern so it is suggested that masking tape be used to temporarily attach the antenna. Perform fade-margin testing, as described in Section 5.4 before permanently mounting.

Permanent mounting: Pre-clean the surface where the antenna is to be mounted with an alcohol wipe. Peel paper protection from adhesive strip and mount to the cleaned surface (see Figures 17, 18, and 19).

Figure 17. Adhesive Mount Antenna – Step 1. Pre-clean the surface



Figure 18. Adhesive Mount Antenna – Step 2. Peel Protection from Adhesive Strip



Figure 19. Adhesive Mount Antenna – Step 3. Mount the Antenna



Mast mount: The benefit of the mast-mount antenna is its rigid design and resistance to displacement when subjected to shock, vibration, wind, etc. It can be easily mounted high above the ground to obtain greater RF signal performance and it withstands winds up to 100 mph.

- Mast-mount bracket (Included with the 8 dBi antenna): Attach antenna to its mounting bracket and tighten nut. Assemble two U-clamps around mast and tighten nuts to ensure lock washers provided are compressed to a flat condition (See Figures 20 and 21).

Figure 20. Mast Mount Antenna – Tighten nut on mounting bracket



Figure 21. Mast Mount Antenna – Side View with Attachment to Pipe



Magnetic mount: The benefit of the magnetic-mount antenna is its ability to mount on any ferrous-metal surface and in various orientations. A smooth metal surface is preferred to allow the best attraction of the magnet to the surface. First, the user will need to determine if the magnetic attraction is sufficient to hold the antenna in the desired position (i.e., shock, vibration, etc. in the application). Placing the antenna in a location where it cannot be inadvertently displaced may help. Magnetic-mount antennas are not designed for mobile applications (see Figure 22).

5.2.4 Antenna Adjustment Considerations

The antenna of the WOI switch and WPMM monitor or WDRR receiver should be oriented in parallel (see Figure 23). This will, in most cases, allow the longest range and highest RF signal. The least RF signal is normally in a direction in-line with the top of the antenna, so avoid having antennas pointed directly toward or directly away from each other.

Figure 22. Magnetic Mount Bracket with Antenna – Mounted on Steel Surface

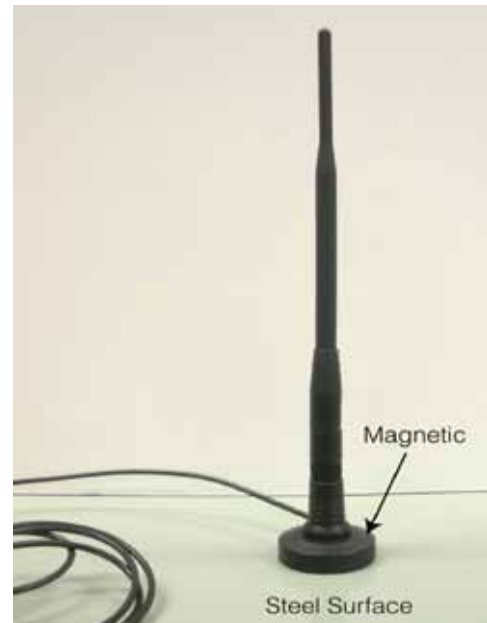
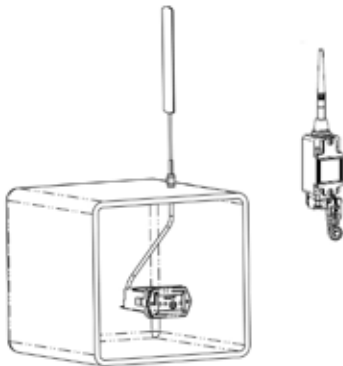

Figure 23. Highest RF signal when antennas are as parallel to each other as possible



5.3 Signal Range of an Antenna

The signal range is defined as the physical distance between the WOI switch and WPMM monitor or WDRR receiver. It's a function of the antenna's gain, radio output of the WOI switch and WPMM monitor or WDRR receiver and cable loss (if used) in conjunction with the environment (i.e. outdoor urban, indoors, etc.) that the Limitless™ product is operating in.

Signal range specification:

305 m [1000 ft] (nominal)

Line of sight with a 2.2 dBi antenna installed on the WOI switch and WPMM monitor or WDRR receiver

5.4 Choosing an Antenna Gain (dBi) With Acceptable Fade-Margin

There are several different antenna gain options in the Limitless™ Series to choose from. This section helps determine the antenna version(s) that will provide suitable RF signal performance for specific applications.

The Limitless™ Series antenna's actual gain is measured by how much of the input power from the internal radio of the WOI switch is concentrated in a particular direction. The WOI switch's antenna transmits RF signals, and also receives RF signals from a Limitless™ WPMM monitor or WDRR receiver. In a particular application, transmit signal strength may be better than the receive signal strength or vice versa. The intent is to choose an antenna with the optimum gain relative to application conditions for both transmitting and receiving.

Fade-margin is the amount of excess power available above and beyond what is necessary to maintain a reliable RF signal between the transmitter and receiver. Normally, an acceptable threshold of excess power to ensure effective operation in a variety of environmental conditions is 10 dB. A simple way to determine if the signal strength is sufficient is to temporarily install a 10 dB attenuator* between the RP-SMA plug of the antenna or remote cable and RP-SMA jack of the WOI switch. This should be completed in an operating application environment with good nominal environmental conditions. When using a WPMM monitor and starting with the antenna desired from Section 5.2.3.2, install the attenuator and operate the system until exposure of all normal application conditions is completed while monitoring the yellow LED (RF link/signal indicator of the WPMM monitor). If the fade-margin is unacceptable, the LED turns on solid indicating that the antenna position on the WOI switch and/or WPMM monitor will need to be changed or another antenna type should be chosen. If using a WDRR receiver; the RF signal strength can be monitored via the RF Signal Strength LEDs. Please refer to the FUNCTIONAL INDICATOR section in the WDRR Installation and Technical Manual for further details of operation.

Try several mounting locations and/or antennas while retesting each with the attenuator to determine the optimal set-up that provides an acceptable fade-margin. Remember to remove the attenuator after testing is completed.

*Suggested sources/part numbers

- 10 dB attenuator (i.e. Crystek – Part number: CATTEN-0100)
- RP-SMA female to SMA male connector adaptor (i.e. Connector City – Part number : ADP-SMAM-RPSF)
- RP-SMA male to SMA female connector adaptor (i.e. Connector City – Part number : ADP-RPSM-SMAF)

5.5 Environment Usage/Concerns

5.5.1 Choosing an Antenna/Cable to Meet Application Exposure Conditions

There is no antenna or cable design impervious to every environmental condition that it could be exposed to. So it is suggested that the application environment be reviewed as follows:

Step	Action
1	Determine where the antenna will be installed and the application conditions: indoor, outdoor, or limited outdoor exposure. Even if the antenna is going to be used indoors, an outdoor antenna may be more suitable (i.e., resistant to fluids, rigid construction, etc.)
2	Determine what the antenna may be subjected to (i.e., fluids, chemicals, oils, wind, shock, vibration, etc.).
3	<ul style="list-style-type: none"> A. Review antenna and/or cable materials (listed in Section 5.1) against resistance to chemicals and fluids. If choosing an adhesive mount, adhesive resistance testing may be necessary. B. If shock, vibration, wind, rain, sleet/snow, etc. are in the application, choose an antenna rated for outdoors and has a rigid design as defined in Sections 5.1 and 5.2.3.2.
4	<p>The WOI's enclosure is designed to meet IP65 seal requirements; however, this step may be required to provide an extra level of protection, especially if the application may be subjecting antennas and cables to liquids. The RP-SMA connections, tilt/swivel joints, and cable entrances are potential leak paths that could lead to corrosion. The following procedure is one way to provide extra protection to these connections and joint</p> <p>Ensure that the area you are applying tape to is clean from contaminants by first cleaning with mild detergent/water and completely dry. Follow with an isopropyl alcohol wipe of the area.</p> <ul style="list-style-type: none"> Layer 1: Wrap a layer of polyvinyl chloride insulating tape Layer 2: Wrap a layer of Rubber splicing tape i.e. Scotch™ 23 Layer 3: Wrap a layer of UV stable polyvinyl chloride insulating tape <p>Layer 1 allows the user to remove Layer 2 for connector inspection, antenna replacement, repositioning of the tilt/swivel antenna, etc.</p> <p>See Figure 24 as an example of the tapes applied to a RP-SMA jack antenna connection. The lime/black antenna guard is not required to be installed.</p>

Figure 24. Tapes applied to an antenna location (as shown on a WGLA Series Switch)



In the end, the antenna/cable choice may need to be tested in the actual application conditions to prove suitability.

5.5.2 Outdoor Antenna Installations - Lightning Concerns

Outdoor antenna installations can lead to the possible damage caused by nearby lightning strikes that induce charges or surges on the antenna and/or antenna extension cables.

A lightning arrestor such as the AL-NFNFB-9 from Hyperlink Technologies can be reviewed against application requirements.

ATTENTION

National, local and/or regulatory agencies may require the use of a lightning arrestor and possibly other requirements for an antenna system installation. It is recommended that the customer review and adhere to these requirements.

5.5.3 RF Interference

The WOI switch and WPMM or WDRR radio operate in the 2.4 GHz range. Upon initial pairing with the WOI switch, the WPMM's or WDRR's radio will automatically scan each of the 9 or 12 channels in the 2.4 GHz range and choose a channel with the least amount of usage. This provides a level of protection from RF interference as the chosen channel where RF communication is low will have a lower chance of signal collision.

However, if multiple RF sources exist in the chosen channel, the external source has an extremely high power intensity, or it is in close proximity to the Limitless™ Series antenna, RF interference can cause an RF signal to not reach the WOI switch, WPMM monitor, or WDRR receiver. RF interference can be caused by many sources (i.e., other radios in the same operating range, solar activity, high frequency digital products, conventional microwave ovens, etc.). If the Limitless™ Series is in an environment with a high usage of products in the 2.4 GHz range, or the RF environment is unknown, an on-site RF survey may prove to be valuable in identifying possible RF interference sources along with other existing wireless devices.

Once the RF sources are identified and located, it may allow the Limitless™ Series antennas to be moved away from the identified RF sources to achieve acceptable performance. The other option is removing the external source, if feasible.

5.6 WOI Mounting/Actuation

Mounting: The WOI housing has two mounting holes that will accept a M4 or #8 size screw; see diameter 4,6 mm [0.18 in] dimensioned below in Figure 25.

Actuation: The WOI Series has two different type of actuation methods, either momentary or maintained (push-pull) and three different button styles, flush, 29 mm mushroom and 40 mm mushroom. The flush button (see Figure 26, red button example) is a momentary only design, the 29 mm mushroom (see Figure 26, green button example) is available in a momentary only design, and the 40 mm is a maintained (push-pull) design (see Figure 26, yellow button example).

Figure 25. Limitless™ WOI dimensions

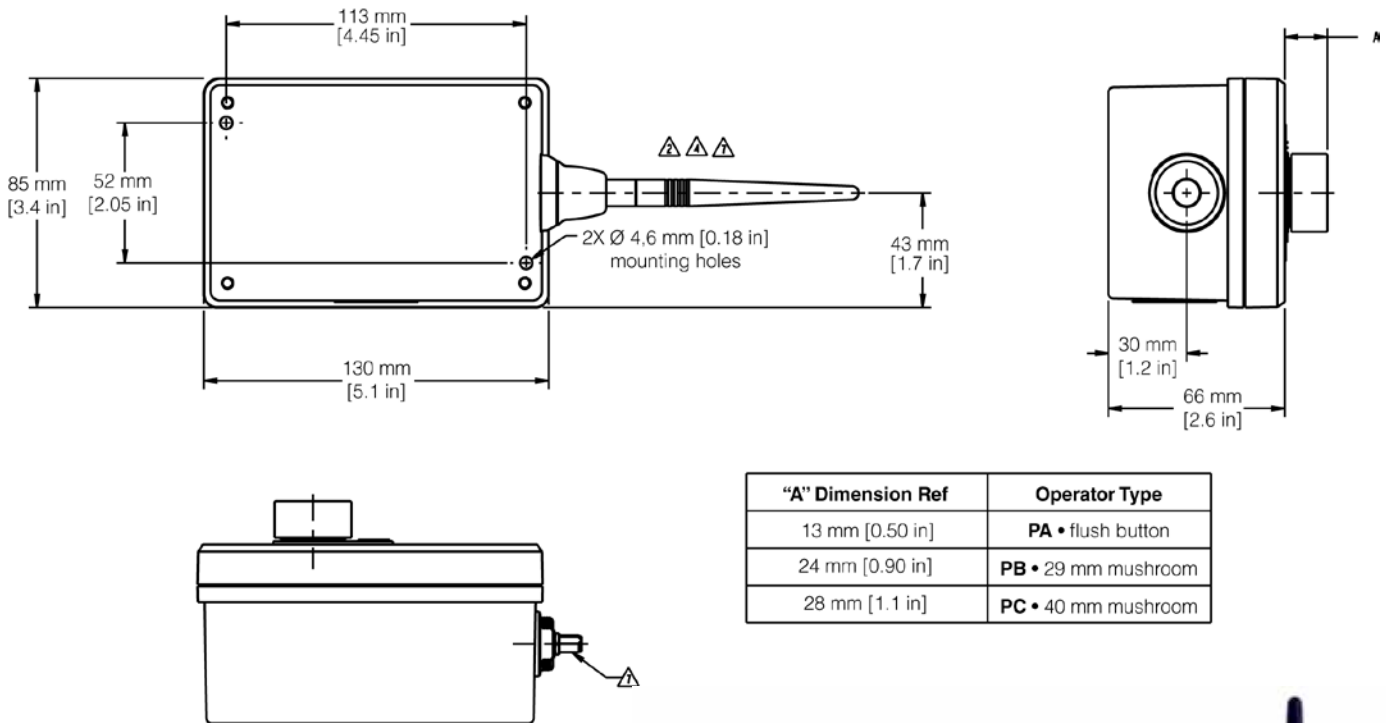

Figure 26. Limitless™ WOI with button options



6 INSPECTION AND MAINTENANCE

6.1 WOI Inspection and Replacement

Periodic inspection

- Check the WOI housing and the actuator for signs of damage. Replace if necessary

6.2 Antenna Inspection and Replacement

Periodic inspection

- Check antenna or cable connection to WOI connector to ensure it is tight and no signs of damage or corrosion. Replace if necessary per Section 5.2.3.1.

6.3 Battery Replacement

When to replace

- Battery is dead or low. The WPMM and WDRR will indicate a low battery condition when a yellow LED is flashing. Upon this indication, proceed with replacing the battery in the WOI as per below.

Tools required

- Slotted or Phillips screwdriver

WARNING

RISK OF DEATH OR SERIOUS INJURY FROM EXPLOSION OR FIRE

Connection and disconnection of the batteries should only be performed in a non-hazardous area. The batteries used in this device may present a risk of fire or chemical burn if mistreated. Do not recharge, disassemble, heat above 100°C [212°F], or incinerate.

Failure to comply with these instructions could result in death or serious injury.

WARNING

RISK OF DEATH OR SERIOUS INJURY FROM EXPLOSION OR FIRE

If WOI Series switch is to be returned to Honeywell for any reason, the battery MUST be removed prior to shipping. Dispose of used batteries promptly per local regulations or the battery manufacturer's recommendations. Keep away from children. Do not disassemble and do not dispose of in fire.

Failure to comply with these instructions could result in death or serious injury.

WARNING

When installing the battery, do not snag the battery terminal on the clip or the battery may be damaged. Do not apply excessive force. Do not drop. Dropping the battery may cause damage. If a battery is dropped, do not install the dropped battery into the WOI. Dispose of dropped battery promptly per local regulations or per the battery manufacturer's recommendations

Failure to comply with these instructions could result in death or serious injury.

ATTENTION

RISK OF DEATH OR SERIOUS INJURY FROM EXPLOSION OR FIRE

Use only the following 3.6V lithium thionyl chloride (Li-SOCl₂) battery (non-rechargeable), size 2/3AA. No other batteries are approved for use in the WOI Series.

- Uniwell, DEV-10-0009
- Green Energy, ER14335M
- Honeywell, WBT1

Reference Figure 27.

Step	Action
1	Remove the four screws ① on the housing cover.
2	Remove old battery from the battery holder ②. If needed, pry out battery by using a slotted screwdriver as a lever on the holder's side slots.
3	Install battery as follows to avoid damage to the battery and holder: <ul style="list-style-type: none"> • See label in battery holder defining the “+” and “-” terminals ③ to ensure battery is placed in holder with correct polarity. • Do not attempt to bend the battery's hold-down tabs forward. • Insert the battery negative end under the hold-down tab, at an angle, and against the end of the spring tab ④. Simultaneously move the negative end of the battery into position, compressing the spring tab, and angle the positive end into the holder ⑤.
4	Replace cover and retighten screws ①.
5	Dispose of used battery promptly per local regulations or the battery manufacturer's recommendations. Keep away from children. Do not disassemble and do not expose of in fire.

Note: Re-pairing via pairing mode is not required after installing a new battery

Figure 27. Limitless™ WOI Battery Replacement

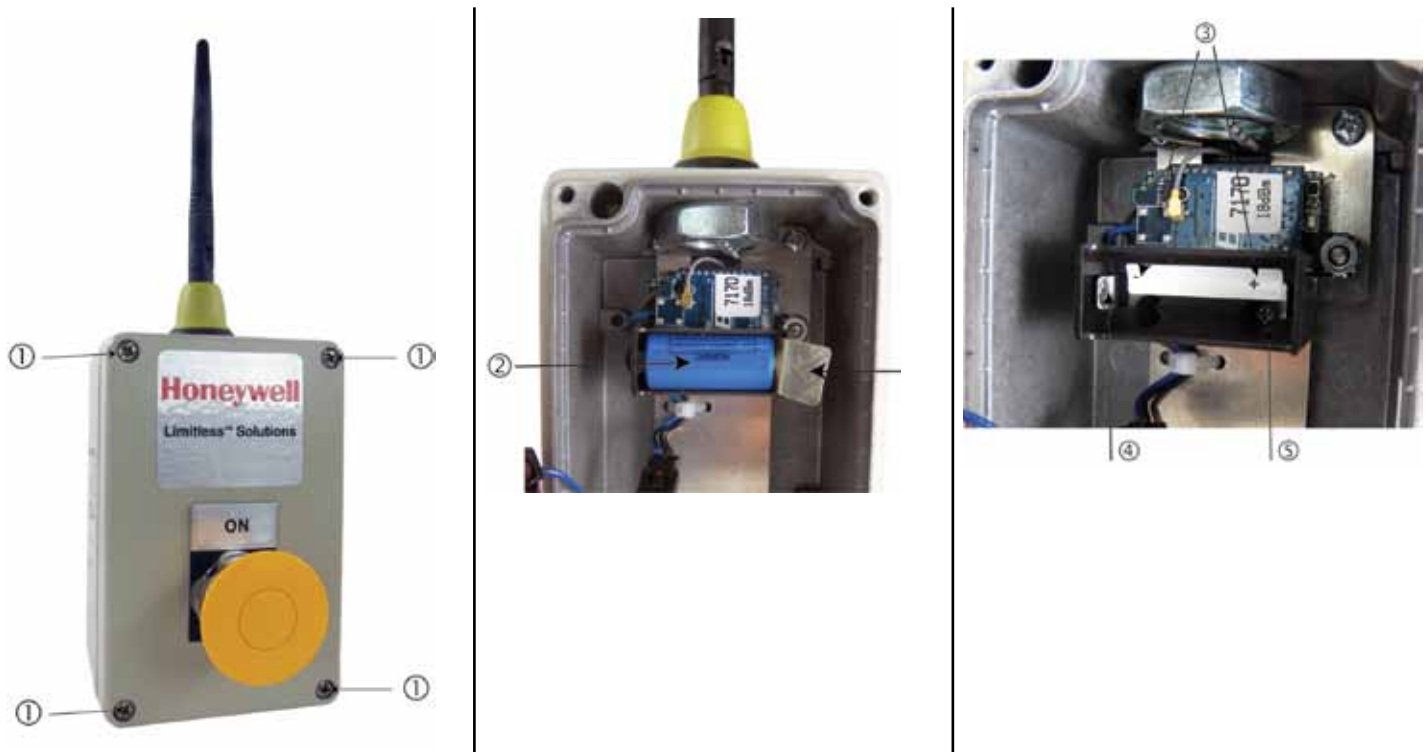

7 ACCESSORIES

7.1 Antenna Options

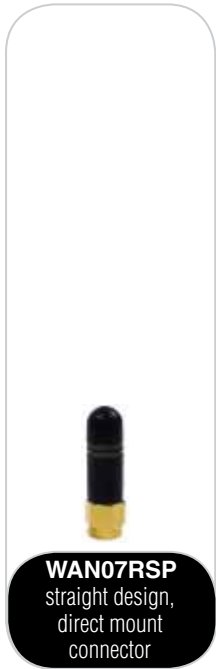

7.2 Antenna Cable Options

WCA200RNPRSP-002 Cable Assembly: 2 ft¹
WCA200RNPRSP-010 Cable Assembly: 10 ft¹



¹ use only with WAN06RNJ antenna and when extra cable is desired

WCA200RNJRSP-002 Cable Assembly: 2 feet length²
WCA200RNJRSP-005 Cable Assembly: 5 feet length²
WCA200RNJRSP-010 Cable Assembly: 10 feet length²
WCA200RNJRSP-015 Cable Assembly: 15 feet length²
WCA200RNJRSP-020 Cable Assembly: 20 feet length²

² Use when extra cable length is desired and allows connection from RP-SMA jack to RP-SMA plug

7.3 Mounting Options

Limitless™ Panel Mount Accessories

WAMM100RSP-005 Magnetic Antenna Mount: w/ 5 ft of cable³
WAMM100RSP-010 Magnetic Antenna Mount: w/ 10 ft of cable³



³ Use only with WAN01RSP, WAN02RSP, WAN04RSP, WAN05RSP, or WAN08RSP antennas

8 INSTALLATION DRAWINGS

8.1 Drawing Availability

Complete installation drawings for each listing of the Limitless™ WOI Series switch and accessories are available at www.honeywell.com/sensing

9 TROUBLESHOOTING GUIDES

9.1 WOI used in conjunction with a WPMM

The troubleshooting guide includes WPMM indications and symptoms as it is being used in conjunction with the WOI. Refer to Figure 28 for layout of LEDs, terminals, connections, etc.

SYMPTOM	CAUSE	RESOLUTION
Green LED ④ is not ON	10 Vdc to 30 Vdc is not applied to "+" & "-" terminals ②③	Check for proper connection and 10 Vdc to 30 Vdc to "+" and "-" terminals ②③
	Power leads connected in reverse	Check for proper connection of power: "+" and "-" terminals ②③
Green ④, yellow ⑤ and/or red ⑦ LEDs do not blink ON at start-up	WPMM internal electronics damaged	Replace WPMM
	LED(s) burnt out ④⑤⑦	Replace WPMM
Green ④, yellow ⑤, and red ⑦ LEDs are momentarily OFF then ON with possible output change during normal operation. Resulting in only green ④ LED on and possibly incorrect yellow ⑤ and red ⑦ LED indication/output for up to 30 seconds.	ESD/EMI exposure beyond published specifications or device performing self check	Determine source for ESD/EMI emissions in application and take action to remove
Yellow LED ⑤ is flashing	Low battery in WOI switch	<ul style="list-style-type: none"> Determine which WOI switch has a low battery using the procedure in the TROUBLESHOOTING MODE section of the WPMM Installation and Technical manual. Replace WOI switch battery per Section 6.3
	Incorrect battery installed in WOI switch	<ul style="list-style-type: none"> Determine which WOI switch has a low battery using the procedure in the TROUBLESHOOTING MODE section of the WPMM Installation and Technical manual. Replace WOI switch battery per Section 6.3

Figure 28. Limitless™ WPMM with call-outs



SYMPTOM	CAUSE	RESOLUTION
Yellow LED is constantly ON	Dead or Low battery in WOI switch	<ul style="list-style-type: none"> Determine which WOI switch has a low battery using the procedure in the TROUBLESHOOTING MODE section of the WPMM Installation and Technical manual WOI switch status will in this case be reported as insufficient RF Replace WOI switch battery per Section 6.3
	Incorrect battery installed in WOI switch	<ul style="list-style-type: none"> Determine which WOI switch has a low battery using the procedure in the TROUBLESHOOTING MODE section of the WPMM Installation and Technical manual. WOI switch status will in this case be reported as insufficient RF Replace WOI switch battery per Section 6.3
	RF range/distance between WPMM and WOI switch is beyond capability	Reposition WOI switch closer to the WPMM until yellow LED is no longer ON
	Exposure to adjacent materials/objects and/or materials/objects	Reposition WOI switch away from objects until yellow LED is no longer ON
	Damage or missing antenna from WPMM and/or WOI switch	Replace antenna; reference Section 5.2.3.1
	Antenna alignment is not acceptable	Reposition antenna; reference Section 5.2.4
	Damage to antenna cable	Replace antenna cable; reference Section 5.2.3.1
	Loose antenna or cable connections	Check connections and tighten as necessary; reference Section 5.2.3.1

SYMPTOM	CAUSE	RESOLUTION
Red LED ⑦ is not ON and buzzer does not sound when WOI switch is actuated (green LED ④ ON, yellow LED ⑤ OFF) *	WOI switch is not paired to WPMM	Pair WOI switch to WPMM per Section 4.4
	WPMM buzzer was set to "mute" during initial set-up	Refer to WPMM Installation and Technical Manual as the WPPMM will need to be factory reset, and paired to the WOI switch(es)
	Actuator /contact blocks in WOI are nonfunctional or defective	Replace actuator /contact blocks per switch manufacturer's instructions
	WOI switch internal electronics damaged	Replace WOI switch
	Yellow LED ⑤ burnt out or damaged electronics of WPMM	Replace WPMM
	Red LED ⑦ burnt out	Replace WPMM
Buzzer not sounding when WOI™ switch is actuated (green LED ④ ON, yellow LED ⑤ OFF) * <i>*Dependant on if the WPMM Set-up mode was used during initial set-up, this operation may be expected</i>	WOI switch is not paired to WPMM	Pair WOI switch to WPMM per Section 4.4
	WPMM buzzer was set to "mute" during initial set-up	Refer to WPMM Installation and Technical Manual as the WPPMM will need to be factory reset, and paired to the WOI switch(es)
	Actuator /contact blocks in WOI are nonfunctional or defective	Replace actuator /contact blocks per switch manufacturer's instructions
	WOI switch internal electronics damaged	Replace WOI switch
	Yellow LED ⑤ burnt out or damaged electronics of WPMM	Replace WPMM
	Buzzer burnt out	Replace WPMM
Electrical output is not changing state when WOI switch is actuated (green LED ④ ON, yellow LED ⑤ OFF)	WOI switch is not paired to WPMM	Pair WOI switch to WPMM per Section 4.4
	Incorrect connections	Check for correct connections to output terminal "O" ① with respect to minus "-" terminal ②
	Actuator /contact blocks in WOI switch are nonfunctional or defective	Replace actuator /contact blocks per switch manufacturer's instructions
	WOI switch internal electronics damaged	Replace WOI switch
	Damaged output	Replace WPMM

9.2 WOI used in conjunction with a WDRR

The troubleshooting guide includes WDRR indications and symptoms as it is being used in conjunction with the WOI. Refer to Figure 29 for layout of LEDs, terminals, connections, etc.

SYMPTOM	CAUSE	RESOLUTION
Green power LED ⑩ is not ON	10 Vdc to 28 Vdc is not applied to "+" & "-" terminals ② ③	Check for proper connection and 10 Vdc to 28 Vdc to "+" and "-" terminals ② ③
	Power leads connected in reverse	Check for proper connection of power: "+" and "-" terminals ② ③
Green, yellow and/or red configuration LEDs ⑪ do not blink ON at start-up	WDRR internal electronics damaged	Replace WDRR
	LED(s) burnt out ⑪	Check LED ⑪ operation referencing "Tri-color Output LEDs" section (RF Link position "F") described in the WDRR Installation and Technical Manual and replace WDRR if necessary
Tri-color output LEDs ⑨ are momentarily OFF then ON with possible NPN/PNP output change during normal operation. Resulting in only green Power LED on and possibly incorrect yellow and red LED ⑨ indication/output for up to 30 seconds.	ESD/EMI exposure beyond published specifications or device performing self check	Determine source for ESD/EMI emissions in application and take action to remove
Yellow LED ⑨ is flashing	Low battery in WOI switch	<ul style="list-style-type: none"> Determine which WOI switch has a low battery by visually inspecting the tri-color output LEDs ⑨ as one or more should be flashing yellow (see WDRR Installation and Technical Manual) Replace WOI switch battery per Section 6.3
	Incorrect battery installed in WOI switch	<ul style="list-style-type: none"> Determine which WOI switch has a low battery by visually inspecting the tri-color output LEDs ⑨ as one or more should be flashing yellow (see WDRR Installation and Technical Manual) Replace WOI switch battery per Section 6.3

Figure 29. Limitless™ WDRR with call-outs

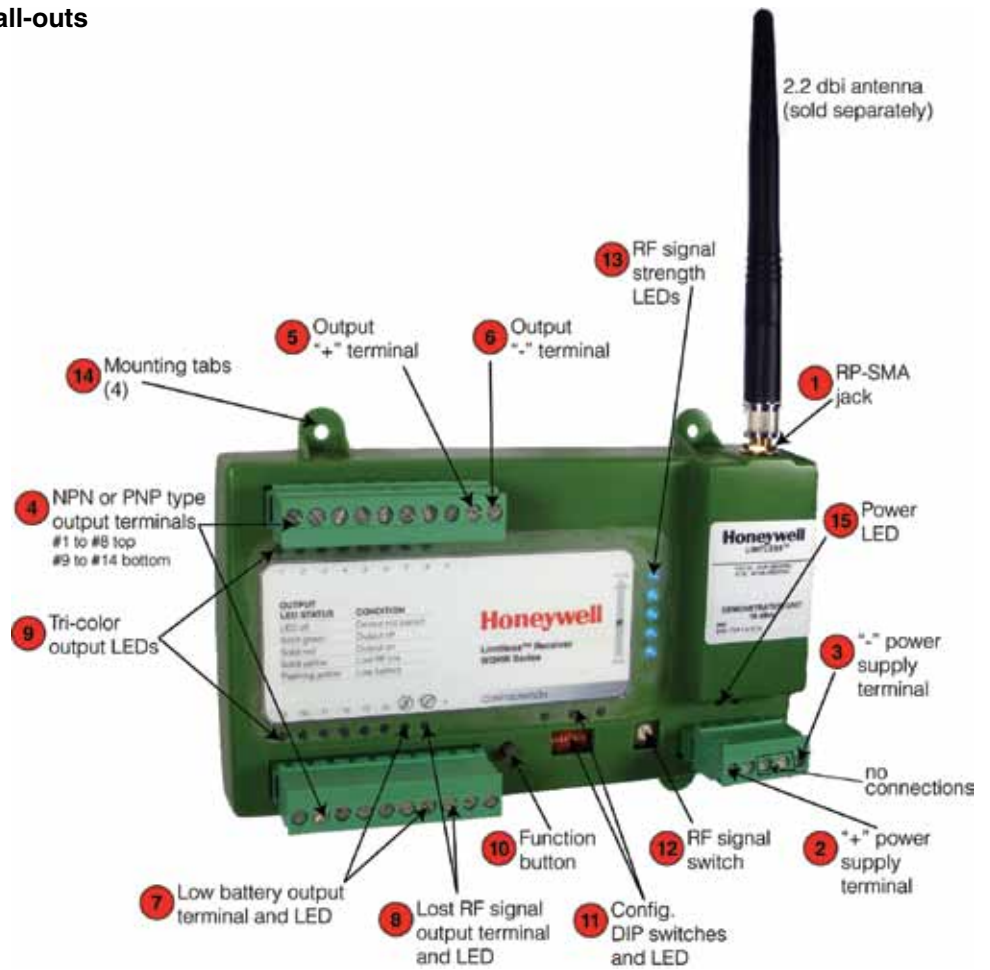

SYMPTOM	CAUSE	RESOLUTION
Yellow tri-color output LED ⑨ is constantly ON	Dead or low battery in WOI switch	<ul style="list-style-type: none"> Determine which WOI switch has a low battery by visually inspecting the tri-color output LEDs ⑨ as one or more should be flashing yellow (see WDRR Installation and Technical Manual) WOI switch status will in this case be reported as lost RF Replace WOI switch battery per Section 6.3
	Incorrect battery installed in WOI switch	<ul style="list-style-type: none"> Determine which WOI switch has a low battery by visually inspecting the tri-color output LEDs ⑨ as one or more should be flashing yellow (see WDRR Installation and Technical Manual) WOI switch status will in this case be reported as lost RF Replace WOI switch battery per Section 6.3
	RF range/distance between WDRR and in WOI switch is beyond capability	Reposition WOI switch closer to the WDRR until yellow LED ⑨ is no longer ON
	Exposure to adjacent materials/objects and/or materials/objects	Reposition WOI switch away from objects until yellow LED ⑨ is no longer ON
	Damage or missing antenna from WDRR and/or in WOI switch	Replace antenna; reference Section 5.2.3.1
	Antenna alignment is not acceptable	Reposition antenna; reference Section 5.2.4
	Damage to antenna cable	Replace antenna cable; reference Section 5.2.3.1
	Loose antenna or cable connections	Check connections and tighten as necessary; reference Section 5.2.3.1
Red tri-color output LED ⑨ is not ON when WOI switch changes state (i.e. switch actuated) (green power LED ⑮ ON, yellow LED ⑨ OFF)	WOI switch is not paired to WDRR	Pair in WOI switch to WDRR
	Actuator /contact blocks in WOI are nonfunctional or defective	Replace actuator /contact blocks per switch manufacturer's instructions
	WOI switch internal electronics damaged	Replace in WOI switch
	Tri-color LED ⑨ burnt out or damaged electronics of WDRR	Replace WDRR
	Tri-color red LED ⑨ burnt out	Check LED ⑩ operation referencing "Tri-color Output LEDs" section (RF Link position "F") described in the WDRR Installation and Technical Manual and replace WDRR if necessary
NPN/PNP output(s) ④ is not changing state when WOI switch(es) is actuated (green power LED ⑮ ON, yellow LEDs ⑨ OFF)	WOI switch(es) not paired to WDRR	Pair WOI to WDRR per Section 4.4
	Incorrect connections	Check for correct connections to output terminal(s) ④
	Replace actuator /contact blocks per switch manufacturer's instructions	Actuator /contact blocks in WOI are nonfunctional or defective
	WOI switch internal electronics damaged	Replace WOI switch
	Damaged output(s)	Replace WDRR receiver

WARRANTY/REMEDY

Honeywell warrants goods of its manufacture as being free of defective materials and faulty workmanship. Honeywell's standard product warranty applies unless agreed to otherwise by Honeywell in writing; please refer to your order acknowledgement or consult your local sales office for specific warranty details. If warranted goods are returned to Honeywell during the period of coverage, Honeywell will repair or replace, at its option, without charge those items it finds defective. **The foregoing is buyer's sole remedy and is in lieu of all other warranties, expressed or implied, including those of merchantability and fitness for a particular purpose. In no event shall Honeywell be liable for consequential, special, or indirect damages.**

While we provide application assistance personally, through our literature and the Honeywell web site, it is up to the customer to determine the suitability of the product in the application.

Specifications may change without notice. The information we supply is believed to be accurate and reliable as of this printing. However, we assume no responsibility for its use.

SALES AND SERVICE

Honeywell serves its customers through a worldwide network of sales offices, representatives and distributors. For application assistance, current specifications, pricing or name of the nearest Authorized Distributor, contact your local sales office or:

E-mail: info.sc@honeywell.com

Internet: www.honeywell.com/sensing

Phone and Fax:

Asia Pacific	+65 6355-2828
	+65 6445-3033 Fax
Europe	+44 (0) 1698 481481
	+44 (0) 1698 481676 Fax
Latin America	+1-305-805-8188
	+1-305-883-8257 Fax
USA/Canada	+1-800-537-6945
	+1-815-235-6847
	+1-815-235-6545 Fax

Sensing and Control
Honeywell
1985 Douglas Drive North
Golden Valley, MN 55422
honeywell.com



50077275-1-EN IL50 GLO Printed in USA.
August 2012
© 2012 Honeywell International Inc. All rights reserved.