

100-8500MHz DPDT Antenna cross Switch

Features

- Broadband frequency range: 100 to 8500MHz
- Low insertion loss: 0.72dB typical @ 5925MHz
- High isolation: 44dB typical @ 5925MHz
- GPIO interface
- LGA 1.55X1.15-10L package
- No DC blocking capacitors required (unless external DC is applied to the RF ports)

Applications

- 2G/3G/4G/5G antenna switching
- Support Wi-Fi 2.4G 5G, Bluetooth, UWB
- Cellular modems, tablets and USB Devices
- Other RF front-end modules

General Description

The AW12122HLGR is a Silicon-On-Insulator(SOI) DPDT switch with low insertion loss and high Isolation. It can be used to support band switching and mode switching for cellular 4G/5G, data cards and tablets.

The AW12122HLGR is provided in a compact LGA 1.55X1.15-10L package.

Typical Application Circuit

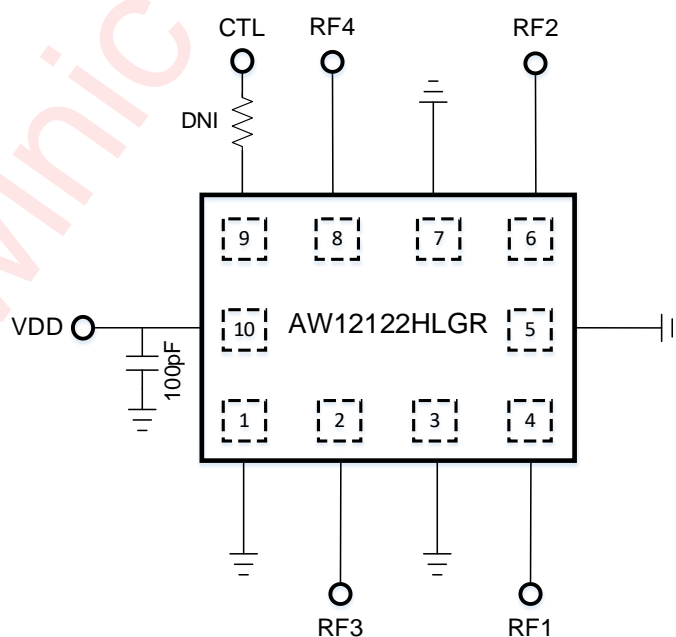

Figure 1 Typical Application Circuit of AW12122HLGR

Pin Configuration And Top Mark

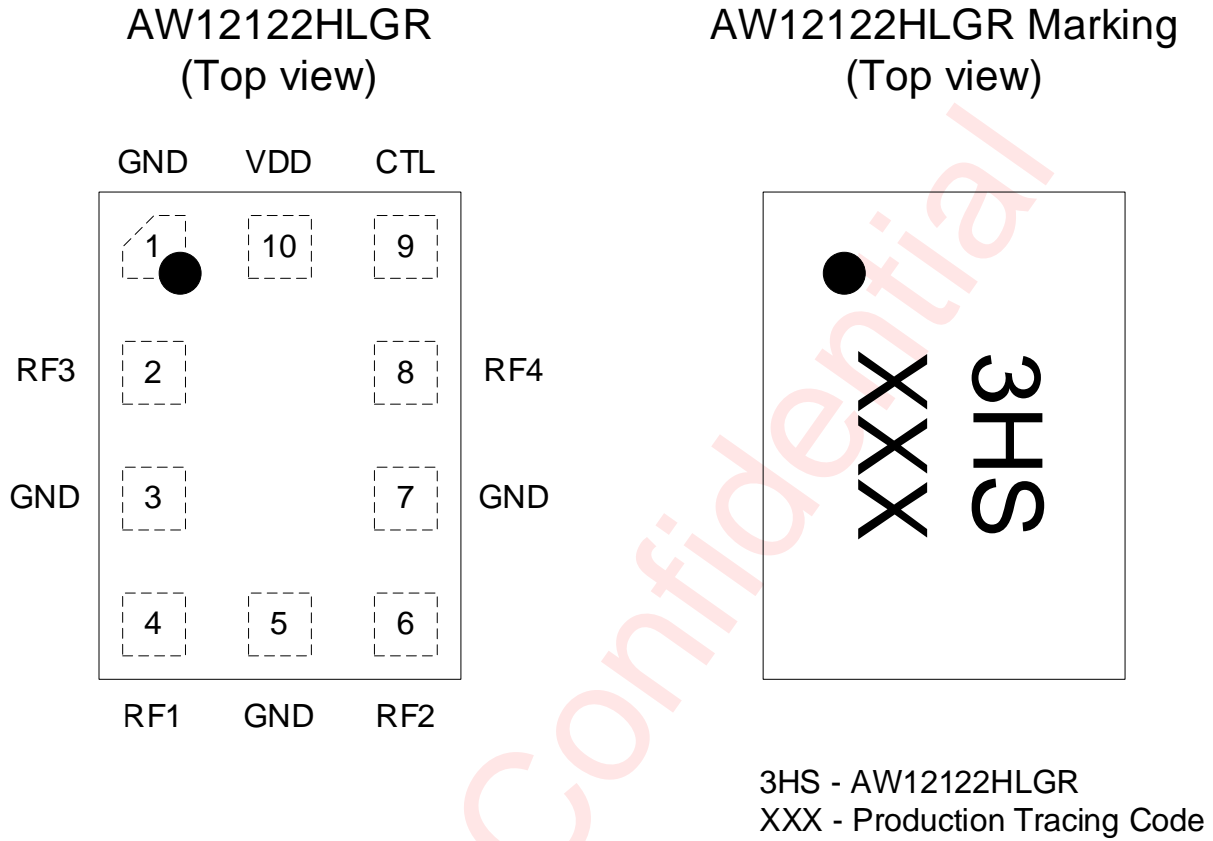

Figure 2 Pin Configuration and Top Mark

Pin Definition

No.	NAME	DESCRIPTION
1	GND	Ground
2	RF3	RF3 port
3	GND	Ground
4	RF1	RF1 port
5	GND	Ground
6	RF2	RF2 port
7	GND	Ground
8	RF4	RF4 port
9	CTL	DC control voltage
10	VDD	DC power supply

Functional Block Diagram

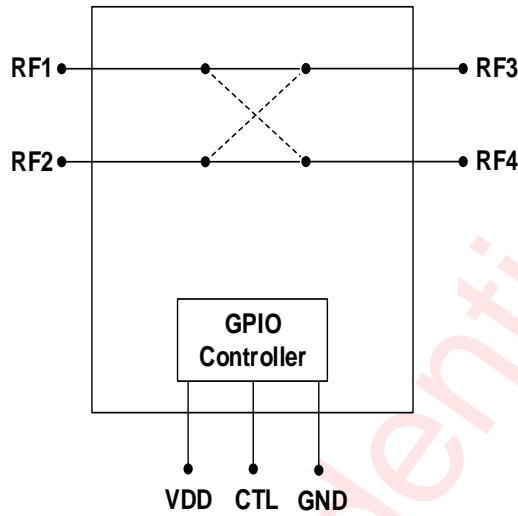

Figure 3 Functional Block Diagram

Ordering Information

Part Number	Temperature	Package	Marking	Moisture Sensitivity Level	Environmental Information	Delivery Form
AW12122HLGR	-40°C~105°C	LGA 1.55X1.15-10L	3HS	MSL3	ROHS+HF	3000 units/ Tape and Reel

Absolute Maximum Ratings^(NOTE1)

PARAMETERS	RANGE
Supply Voltage Range V_{DD}	-0.3V to 3.6V
Control Voltage Range V_{CTL}	-0.3V to 3.6V
RF input power	39.5dBm
Operating Free-air Temperature Range	-40°C to 105°C
Storage temperature T_{STG}	-65°C to 150°C
Lead temperature (soldering 10 seconds)	260°C
ESD	
HBM(Human Body Model) ^(NOTE 2)	±1500V
CDM (Charged Device Model) ^(NOTE 3)	±1500V
LATCH-UP ^(NOTE 4)	+IT: +200mA -IT: -200mA
ESD capability, system level ^(NOTE 5) RF versus system GND, with 27 nH	±6KV

NOTE1: Conditions out of those ranges listed in "absolute maximum ratings" may cause permanent damages to the device. In spite of the limits above, functional operation conditions of the device should within the ranges listed in "recommended operating conditions". Exposure to absolute-maximum-rated conditions for prolonged periods may affect device reliability.

These are stress ratings only and functional operation of the device at these or any other conditions beyond those indicated under "recommended operating conditions" is not implied. Exposure to absolute maximum rated conditions for extended periods may affect device reliability.

NOTE2: The human body model is a 100pF capacitor discharged through a 1.5kΩ resistor into each pin. Test method: ESDA/JEDEC JS-001-2023.

NOTE3: All pins. Test Condition: ESDA/JEDEC JS-002-2022.

NOTE4: Test Condition: JEDEC78F.

NOTE5: Test Condition: IEC 6100-4-2 (R=330 Ω, C=150 pF), contact discharge.

Recommended Operating Conditions

Symbol	Parameter	Min.	Typ.	Max.	Unit
V _{DD}	Supply Voltage	1.65		3.3	V
V _{CTL_H}	Control Voltage High	1.35		V _{DD}	V
V _{CTL_L}	Control Voltage Low	0		0.45	V
T _A	Operating free-air temperature range	-40	25	105	°C

Awinic Confidential

Electrical Characteristics

$V_{DD}=1.8V$, $V_{CTL}=0/1.8V$, $P_{IN}=0dBm$, $Temp=25^{\circ}C$, $VSWR=1:1$. (unless otherwise noted)

PARAMETER		TEST CONDITION	MIN	TYP	MAX	UNIT
DC Specifications						
V_{DD}	Supply Voltage		1.65	1.8	3.3	V
I_{DD}	Supply Current			66	100	μA
I_{CTL}	Control Current			2.7	10	μA
T_{SW_ON}	Switching Speed OFF to ON State	50% V_{CTL} to 90% RF output		2	3	μs
T_{SW_OFF}	Switching Speed ON to OFF State	50% V_{CTL} to 10% RF output		1.2	3	μs
RF Specifications						
IL	Insertion loss	617-960MHz		0.35	0.45	dB
		960-2200MHz		0.41	0.54	dB
		2300-2690MHz		0.44	0.6	dB
		3300-3800MHz		0.52	0.75	dB
		3800-4200MHz		0.54	0.8	dB
		4400-5000MHz		0.62	1	dB
		5150-5925MHz		0.72	1.25	dB
		5925-7125MHz		0.9	1.5	dB
ISO	State 0 RF1-RF2, RF3-RF4	617-960MHz	48	53		dB
		960-2200MHz	43	48		dB
		2300-2690MHz	42	47		dB
		3300-3800MHz	42	46		dB
		3800-4200MHz	41	45		dB
		4400-5000MHz	41	45		dB
		5150-5925MHz	40	44		dB
		5925-7125MHz	35	42		dB
	7125-8500MHz	30	36		dB	
	State 1 RF1-RF2, RF3-RF4	617-960MHz	48	54		dB
		960-2200MHz	45	50		dB
		2300-2690MHz	44	49		dB
		3300-3800MHz	43	48		dB
		3800-4200MHz	43	49		dB
		4400-5000MHz	43	51		dB

PARAMETER		TEST CONDITION	MIN	TYP	MAX	UNIT	
		5150-5925MHz	43	48		dB	
		5925-7125MHz	34	41		dB	
		7125-8500MHz	30	35		dB	
	State 0 RF1-RF4, RF2-RF3		617-960MHz	50	65		dB
			960-2200MHz	50	61		dB
			2300-2690MHz	50	60		dB
			3300-3800MHz	50	59		dB
			3800-4200MHz	50	58		dB
			4400-5000MHz	45	51		dB
			5150-5925MHz	40	45		dB
			5925-7125MHz	34	39		dB
			7125-8500MHz	30	35		dB
			State 1 RF1-RF3, RF2-RF4		617-960MHz	42	46
	960-2200MHz	36			40		dB
	2300-2690MHz	35			39		dB
	3300-3800MHz	34			38		dB
	3800-4200MHz	33			37		dB
	4400-5000MHz	33			37		dB
	5150-5925MHz	33			37		dB
5925-7125MHz	33	37				dB	
7125-8500MHz	31	36		dB			
H2	Second Harmonics VSWR=1:1	GSM850/900 Tx (CW,Pin = 34.5 dBm)		-57	-45	dBm	
		GSM1800/1900 Tx (CW,Pin = 32 dBm)		-62	-50	dBm	
		617-960MHz (CW,Pin = 26 dBm)		-78	-60	dBm	
		960-2200MHz (CW,Pin = 26 dBm)		-77	-60	dBm	
		2300-2700MHz (CW,Pin = 29 dBm)		-69	-55	dBm	
		3300-3800MHz (CW,Pin = 29 dBm)		-72	-55	dBm	
		3800-4200MHz (CW,Pin = 29 dBm)		-72	-55	dBm	
		4400- 5000MHz (CW,Pin = 29 dBm)		-70	-55	dBm	
		5150-5925MHz (CW,Pin = 26 dBm)		-78	-60	dBm	

PARAMETER		TEST CONDITION	MIN	TYP	MAX	UNIT
H3	Third Harmonics VSWR=1:1	GSM850/900 Tx (CW,Pin = 34.5 dBm)		-57	-45	dBm
		GSM1800/1900 Tx (CW,Pin = 32 dBm)		-62	-50	dBm
		617-960MHz (CW,Pin = 26 dBm)		-82	-65	dBm
		960-2200MHz (CW,Pin = 26 dBm)		-79	-60	dBm
		2300-2700MHz (CW,Pin = 29 dBm)		-69	-55	dBm
		3300-3800MHz (CW,Pin = 29 dBm)		-70	-55	dBm
		3800-4200MHz (CW,Pin = 29 dBm)		-70	-55	dBm
		4400- 5000MHz (CW,Pin = 29 dBm)		-69	-55	dBm
		5150-5925MHz (CW,Pin = 26 dBm)		-75	-60	dBm
IIP2	2 nd Order Intercept Point	f1=26dBm, 1950MHz f2=-20dBm, 4090MHz	110	125		dBm
IIP3	3 rd Order Intercept Point	f1=26dBm, 2560MHz f2=-10dBm, 3310MHz	65	71		dBm
VSWR	Voltage Standing Wave Ratio	617-960MHz		1.1	1.4	:1
		960-2200MHz		1.2	1.5	:1
		2300-2690MHz		1.2	1.5	:1
		3300-3800MHz		1.2	1.6	:1
		3800-4200MHz		1.3	1.7	:1
		4400-5000MHz		1.3	1.8	:1
		5150-5925MHz		1.4	1.9	:1
		5925-7125MHz		1.6	2.1	:1
7125-8500MHz		1.7	2.4	:1		
P0.1dB	0.1dB Compression Point	100-5925MHz		39		dBm

Timing Diagram (Power On and Off Sequence)

It is very important that the user adheres to the correct power-on/off sequence in order to avoid damaging the device. The control signal CTL should be set to 0V unless VDD is set in the operating voltage range.

Power ON:

- 1) Apply voltage supply --- VDD
- 2) Set Controls---CTL
- 3) Apply RF input

Change switch position from one RF port to another:

- 1) Remove RF input
- 2) Change control voltages CTL to set the switch to desired RF port
- 3) Apply RF input

Power OFF:

- 1) Remove RF input
- 2) Remove control voltages-CTL
- 3) Remove VDD input

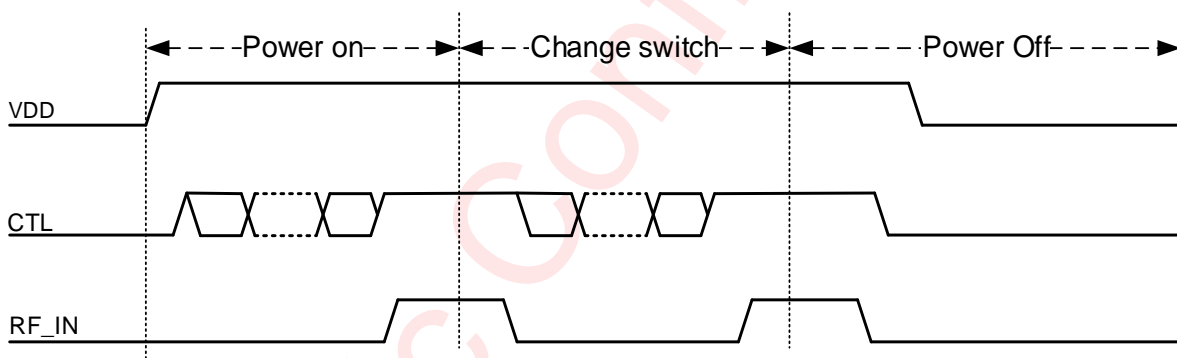

Figure 4 Power On/Change Switch/Power Off Sequence

Control logic

State	Active Path	CTL
0	RF1 to RF3; RF2 to RF4	VCTL_L
1	RF1 to RF4; RF2 to RF3	VCTL_H

Awinic Confidential

Tape And Reel Information

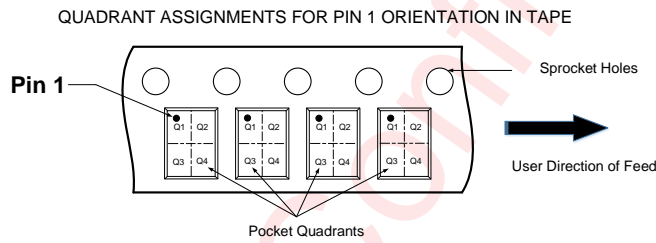
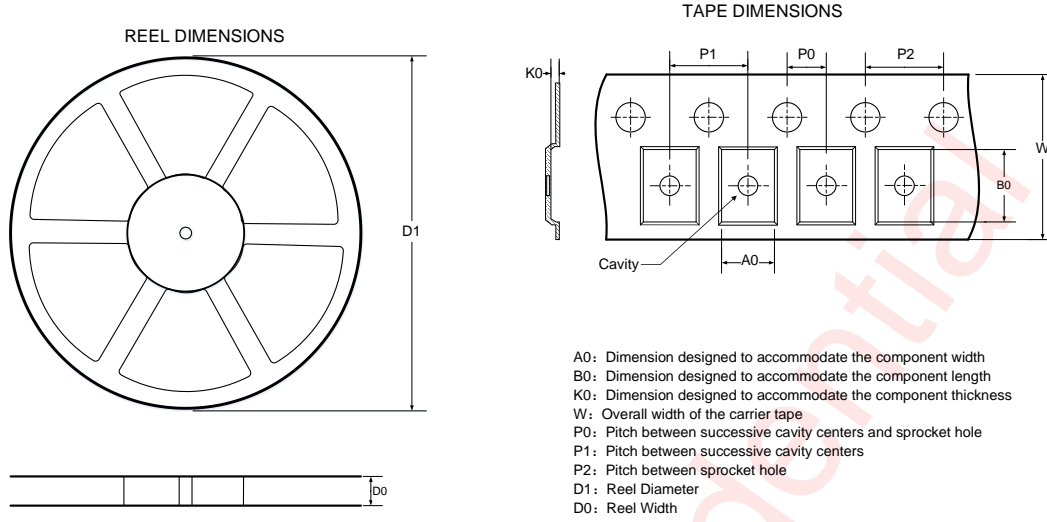

Note: The above picture is for reference only. Please refer to the value in the table below for the actual size

DIMENSIONS AND PIN1 ORIENTATION

D1 (mm)	D0 (mm)	A0 (mm)	B0 (mm)	K0 (mm)	P0 (mm)	P1 (mm)	P2 (mm)	W (mm)	Pin1 Quadrant
178.0	8.40	1.30	1.70	0.75	2.00	4.00	4.00	8.00	Q1

All dimensions are nominal

Figure 5 Tape And Reel Information

Package Description

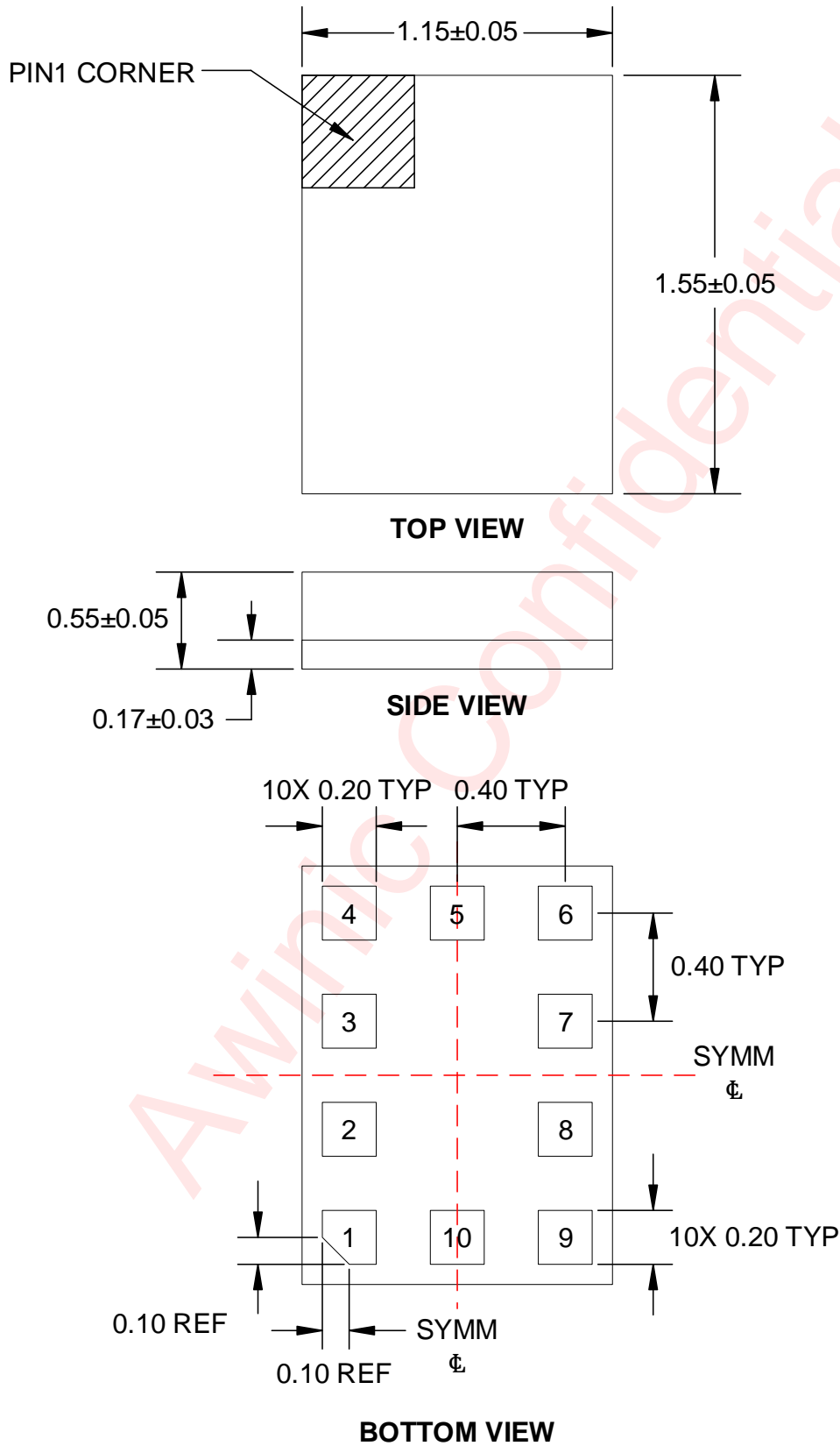

Figure 6 Package Outline

Land Pattern Data

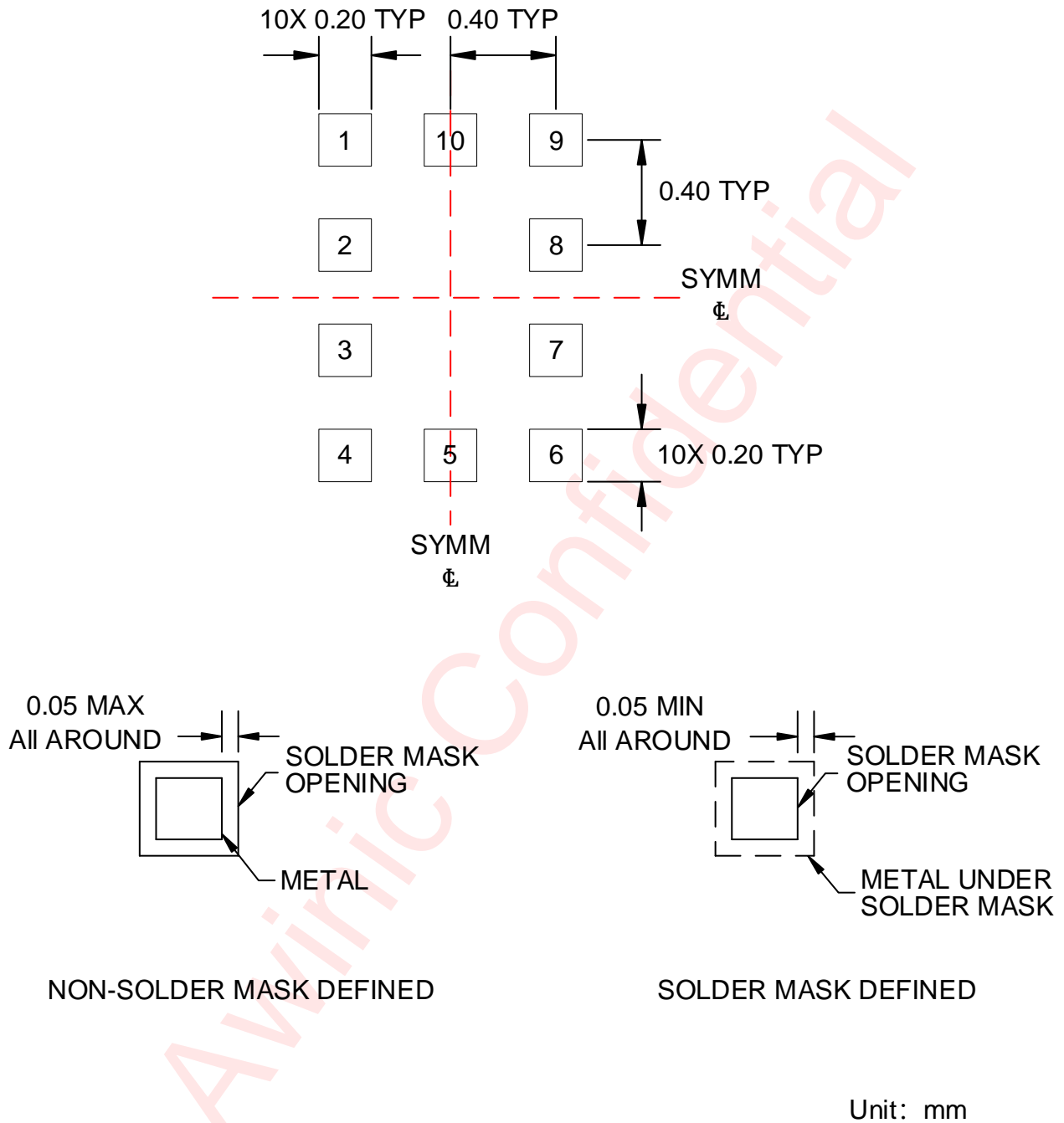

Figure 7 Land Pattern Data

Revision History

Version	Date	Change Record
V1.0	Aug. 2024	Officially released
V1.1	Aug. 2024	Update Electrical Characteristics table, add upper and lower limits
V1.2	Jan. 2026	Update Electrical Characteristics table for UWB Bands

Awinic Confidential

Disclaimer

All trademarks are the property of their respective owners. Information in this document is believed to be accurate and reliable. However, Shanghai AWINIC Technology Co., Ltd (AWINIC Technology) does not give any representations or warranties, expressed or implied, as to the accuracy or completeness of such information and shall have no liability for the consequences of use of such information.

AWINIC Technology reserves the right to make changes to information published in this document, including without limitation specifications and product descriptions, at any time and without notice. Customers shall obtain the latest relevant information before placing orders and shall verify that such information is current and complete. This document supersedes and replaces all information supplied prior to the publication hereof.

AWINIC Technology products are not designed, authorized or warranted to be suitable for use in medical, military, aircraft, space or life support equipment, nor in applications where failure or malfunction of an AWINIC Technology product can reasonably be expected to result in personal injury, death or severe property or environmental damage. AWINIC Technology accepts no liability for inclusion and/or use of AWINIC Technology products in such equipment or applications and therefore such inclusion and/or use is at the customer's own risk.

Applications that are described herein for any of these products are for illustrative purposes only. AWINIC Technology makes no representation or warranty that such applications will be suitable for the specified use without further testing or modification.

All products are sold subject to the general terms and conditions of commercial sale supplied at the time of order acknowledgement.

Nothing in this document may be interpreted or construed as an offer to sell products that is open for acceptance or the grant, conveyance or implication of any license under any copyrights, patents or other industrial or intellectual property rights.

Reproduction of AWINIC information in AWINIC data books or data sheets is permissible only if reproduction is without alteration and is accompanied by all associated warranties, conditions, limitations, and notices. AWINIC is not responsible or liable for such altered documentation. Information of third parties may be subject to additional restrictions.

Resale of AWINIC components or services with statements different from or beyond the parameters stated by AWINIC for that component or service voids all express and any implied warranties for the associated AWINIC component or service and is an unfair and deceptive business practice. AWINIC is not responsible or liable for any such statements.