

High Sensitivity Micropower Unipolar Hall-effect Switch

Features

- High sensitive unipolar operation
- Micropower operation Typ 4.8 μ A
(average : $V_{DD}=1.8V$)
- Ultra small package:
WBDFN 1.4mm \times 1.1mm-4L
- On board voltage regulator for 1.6V to 5.5V range
- Wide operating temperature range:
-40 $^{\circ}$ C to 85 $^{\circ}$ C

Applications

- Smartphone.
- Notebook computer.
- Handheld gaming consoles.
- Bluetooth headset.
- DV.
- Contact-less switch, Level, proximity and position switches in consumer products.

General Description

AW86511FDCBDNR is a high-sensitivity micropower unipolar Hall effect switch IC with internal pull up and pull down capability. AW86511FDCBDNR uses a hibernating clocking system to reduce power consumption, which the total power consumption in normal operation is typically 4.8 μ A with a 1.8V power source. Mainly designed for portable devices such as laptop computer, smartphone and bluetooth headset etc. The supply range of AW86511FDCBDNR is 1.6V to 5.5V to support portable equipment.

The OUTN is activity with a north pole of sufficient magnetic field strength. When the magnetic flux density perpendicular to the package is large than operate point(BopN) , the output will be turned on (pulled down) and hold until B is lower than release point (BrpN). The OUTS is activity with a south pole of sufficient magnetic field strength. When the magnetic flux density perpendicular to the package is large than operate point(BopS) , the output will be turned on (pulled low) and held until B is lower than release point (BrpS).

Typical Application Circuit



Pin Configuration And Top Mark

AW86511FDCBDNR
(Top View)

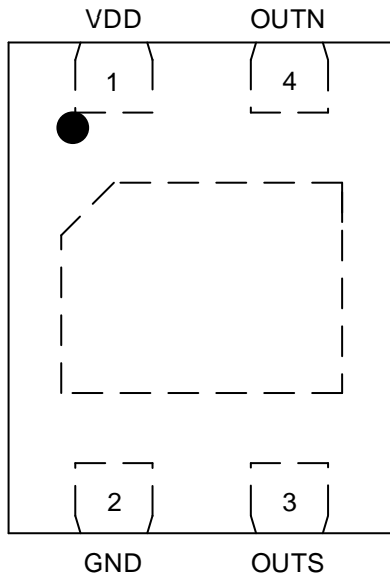

AW86511FDCBDNR Marking
(Top View)

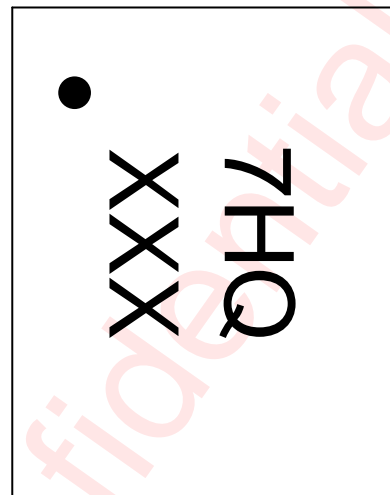

7HQ - AW86511FDCBDNR
XXX - Production Tracing Code

Pin Definition

NO.	Name	Description
1	VDD	Power Supply
2	GND	Ground
3	OUTS	S pole detection output
4	OUTN	N pole detection output
5	Thermal pad	Not Connect

Functional Block Diagram

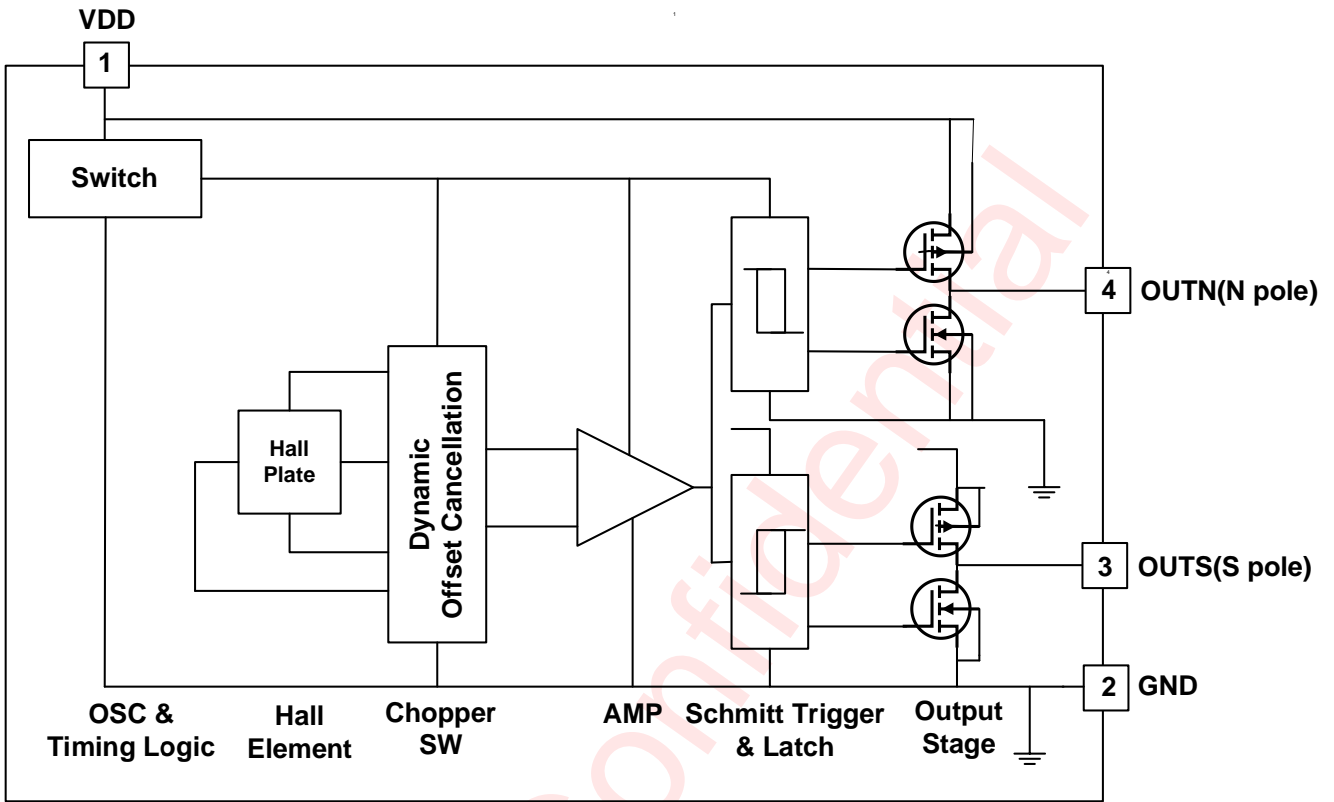

Ordering Information

Part Number	Temperature	Package	Marking	Moisture Sensitivity Level	Environmental Information	Delivery Form
AW86511FDCBDNR	-40°C~85°C	WBDFN 1.4mm×1.1mm -4L	7HQ	MSL1	ROHS+HF	4500 units/ Tape and Reel

Absolute Maximum Ratings (NOTE1)

PARAMETERS	RANGE
Supply Voltage	-0.3V to 6V
Supply Current	3mA
Output Voltage	-0.4V to $V_{DD}+0.4V$
Output Current	3mA
Operating Ambient Temperature T_A	-40°C to 85°C
Storage Temperature T_{STG}	-65°C to 150°C
Junction temperature T_J	-50°C to 165°C
Magnetic Flux	No limit
Lead temperature (soldering 10 seconds)	260°C
ESD Rating(NOTE2 3)	
Human Body Model (HMB) ESD capability	±6kV
Charged-device model (CDM) ESD capability	±1.5kV
Latch-up	
Test Condition: JESD78E	+IT: 200mA
	-IT: 200mA

NOTE1: Conditions out of those ranges listed in "absolute maximum ratings" may cause permanent damages to the device. In spite of the limits above, functional operation conditions of the device should within the ranges listed in "recommended operating conditions". Exposure to absolute-maximum-rated conditions for prolonged periods may affect device reliability.

NOTE2: The human body model test method: ESDA/JEDEC JS -001-2017.

NOTE3: Charge Device Model test method: ESDA/JEDEC JS-002-2018.

Electrical Characteristics

$V_{DD} = 3.3V$, $T_A = 25^\circ C$ for typical values (unless otherwise noted)

Symbol	Characteristic	Test Conditions	Min	Typ	Max	Unit
V_{DD}	Supply Voltage	Operating, $T_J < 165^\circ C$	1.6	-	5.5	V
$I_{DD}(\text{awake})$ (Note1)	Supply Current	During awake period, $T_A = 25^\circ C$, $V_{DD} = 3.3V$	-	0.95	1.3	mA
$I_{DD}(\text{sleep})$		During sleep period, $T_A = 25^\circ C$, $V_{DD} = 3.3V$	-	0.43	0.8	μA
$I_{DD}(\text{avg})$ (Note1)	Average supply current	$T_A = 25^\circ C$, $V_{DD} = 1.8V$, $f_S = 200Hz$	-	4.8	-	μA
		$T_A = 25^\circ C$, $V_{DD} = 3.3V$, $f_S = 200Hz$	-	-	10	μA
V_{OL}	Output low voltage(on)	$I_{OUT} = 1\text{ mA}$	-	0.1	0.2	V
V_{OH}	Output high voltage(off)	$I_{OUT} = -1mA$	$V_{DD} - 0.2$	$V_{DD} - 0.1$	-	V
T_{awake} (Note1)	Awake time	(Note)	-	40	60	μs
T_{period}	Period	$f_S = 200Hz$ (sampling rate)	-	5	11	ms
D.C.	Duty cycle	-	-	0.08	-	%
f_C	Chopping Frequency	-	-	500	-	kHz
I_{OFF} (Note1)	Output Leakage Current	$V_{OUT} = 5.5\text{ V}$; Switch state=off	-	-	0.1	μA

Note: Maximum and minimum parameters values over operating temperature range are not tested in production. They are guaranteed by design, characterization and process control. The magnetic field strength (Gauss) required to cause the switch to change state (operate and release) will be as specified in the magnetic characteristics. To test the switch against the specified magnetic characteristics, the switch must be placed in a uniform magnetic field.

Note1: Minimum and/or maximum limit is guaranteed by design and by statistical analysis of device characterization data. The specification is not guaranteed by production testing.

Magnetic Characteristics

$T_A=25^{\circ}\text{C}$, $V_{DD}=3.3\text{V}$ for typical values (unless otherwise noted)

(1mT = 10Gauss)

Symbol	Characteristics	Test condition	Min	Typ	Max	Unit
Bops (south pole to part marking side)	Operation Point	$T_A = 25^{\circ}\text{C}, V_{DD}=3.3\text{V}$	14	25	32	Gauss
		$T_A = -40^{\circ}\text{C to } 85^{\circ}\text{C}$ $V_{DD} = 1.6\text{V}\sim 5.5\text{V}$	13	25	39	
Bopn (north pole to part marking side)		$T_A = 25^{\circ}\text{C}, V_{DD}=3.3\text{V}$	-32	-25	-14	
		$T_A = -40^{\circ}\text{C to } 85^{\circ}\text{C}$ $V_{DD} = 1.6\text{V}\sim 5.5\text{V}$	-39	-25	-13	
Brps (south pole to part marking side)	Release Point	$T_A = 25^{\circ}\text{C}, V_{DD}=3.3\text{V}$	12	18	30	
		$T_A = -40^{\circ}\text{C to } 85^{\circ}\text{C}$ $V_{DD} = 1.6\text{V}\sim 5.5\text{V}$	9	18	35	
Brpn (north pole to part marking side)		$T_A = 25^{\circ}\text{C}, V_{DD}=3.3\text{V}$	-30	-18	-12	
		$T_A = -40^{\circ}\text{C to } 85^{\circ}\text{C}$ $V_{DD} = 1.6\text{V}\sim 5.5\text{V}$	-35	-18	-9	
Bhy ($ B_{opx} - B_{rpx} $)	Hysteresis	$T_A = -40^{\circ}\text{C to } 85^{\circ}\text{C}$ $V_{DD} = 1.6\text{V}\sim 5.5\text{V}$	-	7	-	

Notes: Typical data is at $T_A=25^{\circ}\text{C}$, $V_{DD}=3.3\text{V}$.

Maximum and minimum parameters values over operating temperature range are not tested in production. They are guaranteed by design, characterization and process control. The magnetic characteristics may vary with supply voltage, operating temperature and after soldering.

Typical Characteristics

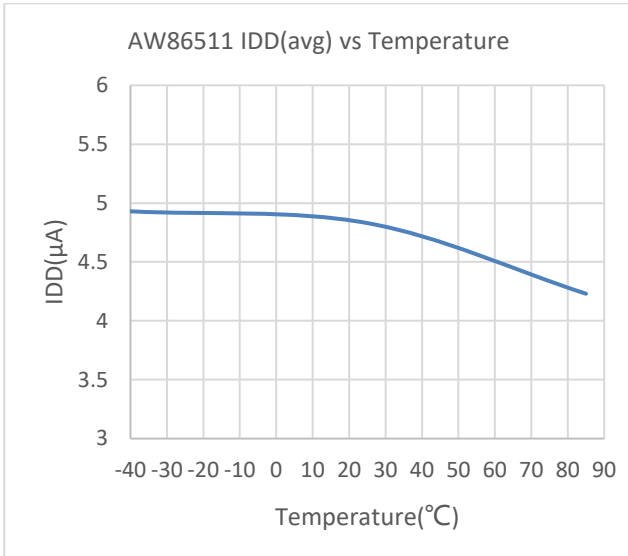

Ambient Temperature T_a [°C] I_{DD} vs. T_a
VDD=1.8V

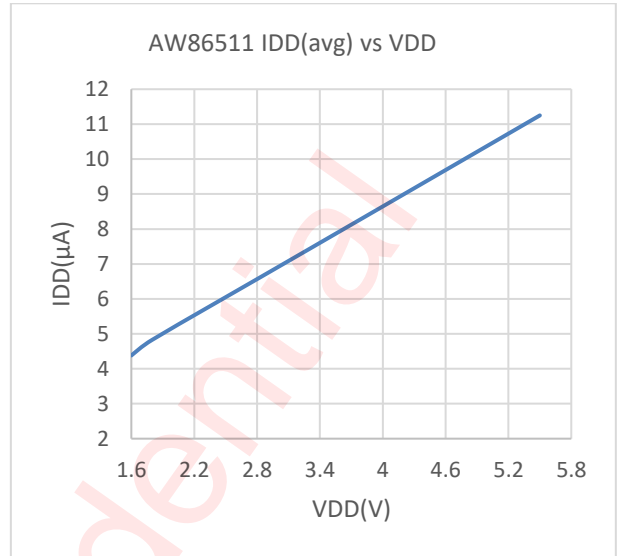

Average Supply Current vs. Supply Voltage
 $T_a=25^\circ\text{C}$

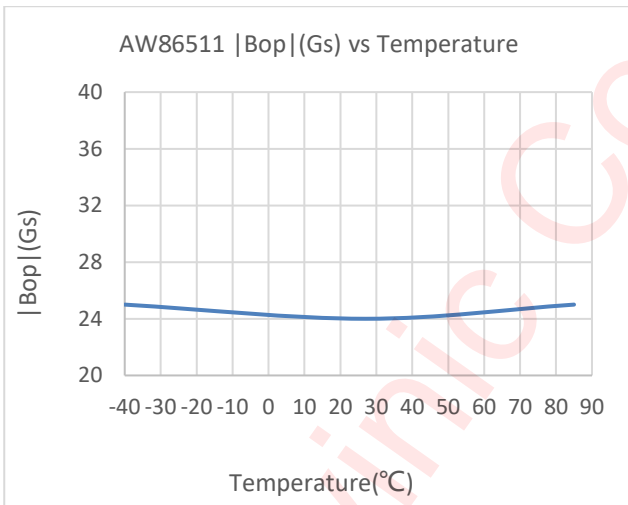

Ambient Temperature T_a [°C] $|B_{op}|$ vs. T_a
VDD=3.3V

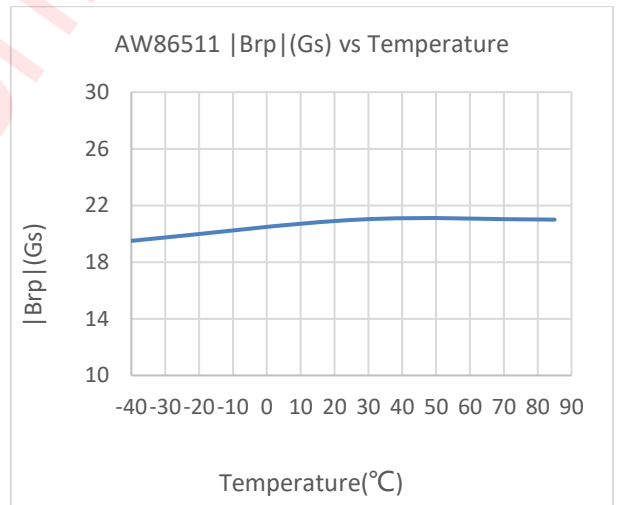

Ambient Temperature T_a [°C] $|B_{rp}|$ vs. T_a
VDD=3.3V

Detailed Functional Description

Magnetic Response

The OUTN is activity with a north pole of sufficient magnetic field strength. When the magnetic flux density perpendicular to the package is larger than operate point (B_{opN}), the OUTN will be turned on (pulled low) and held until B is lower than release point (B_{rpN}). The OUTS is activity with a south pole of sufficient magnetic field strength. When the magnetic flux density perpendicular to the package is larger than operate point (B_{opS}), the OUTS will be turned on (pulled low) and held until B is lower than release point (B_{rpS}).

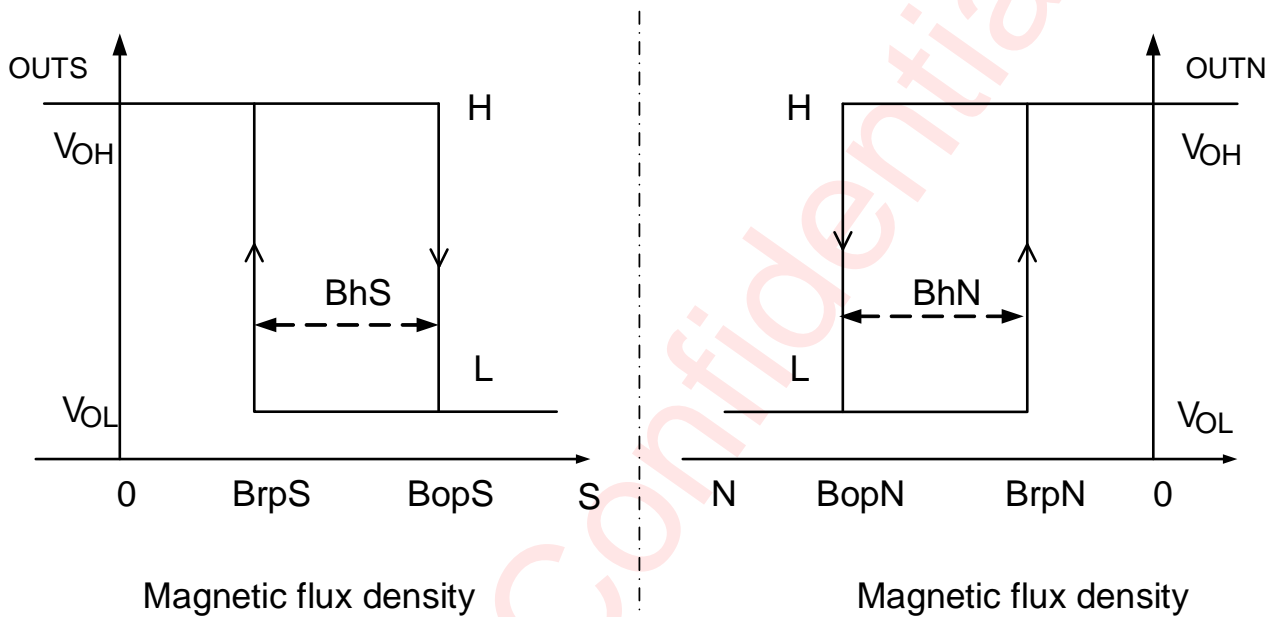

Tape And Reel Information

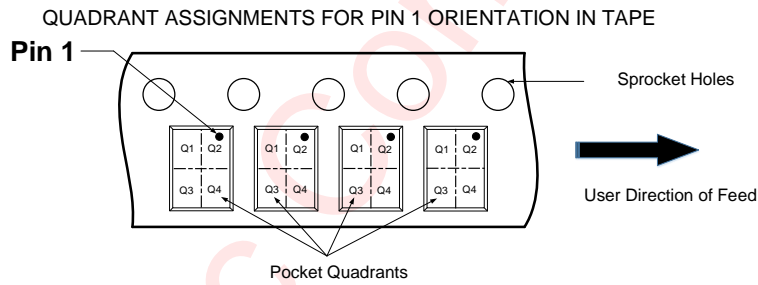
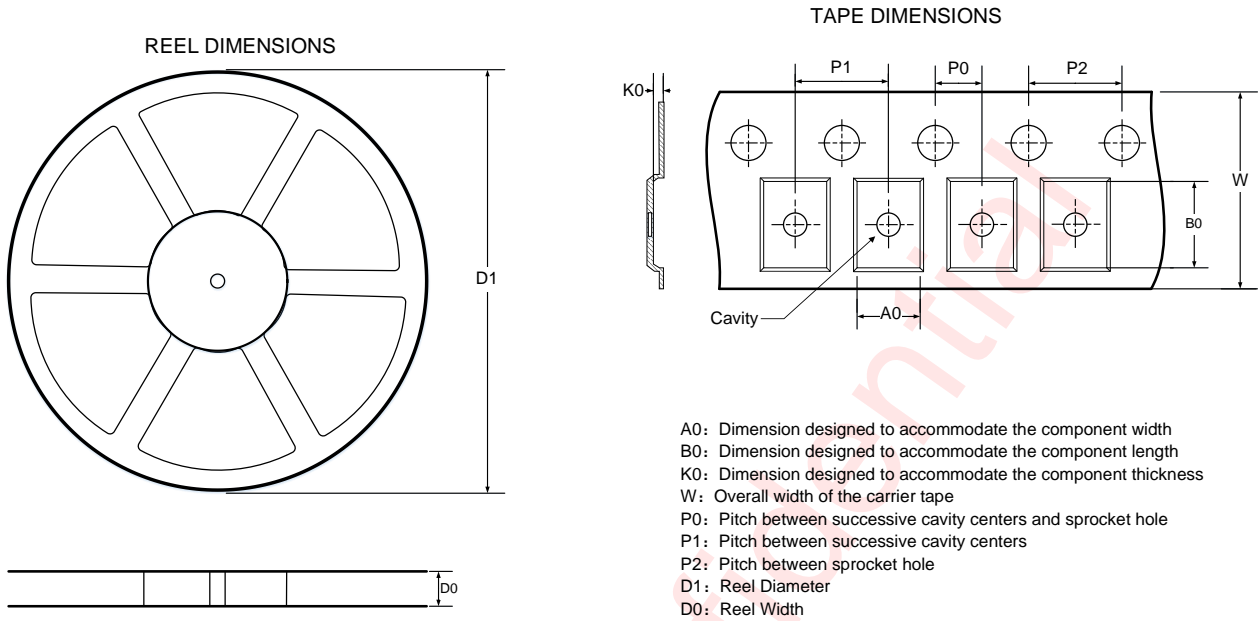

Note: The above picture is for reference only. Please refer to the value in the table below for the actual size

DIMENSIONS AND PIN1 ORIENTATION

D1 (mm)	D0 (mm)	A0 (mm)	B0 (mm)	K0 (mm)	P0 (mm)	P1 (mm)	P2 (mm)	W (mm)	Pin1 Quadrant
178	8.4	1.6	1.3	0.5	2	4	4	8	Q2

All dimensions are nominal

Package Description

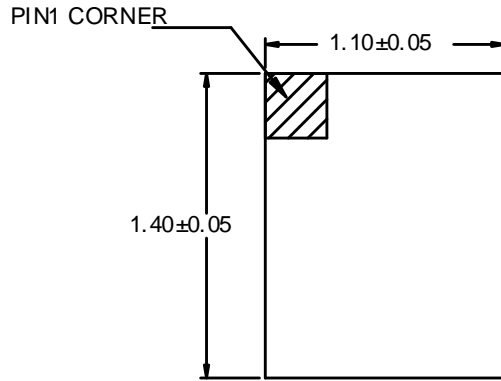

Top View

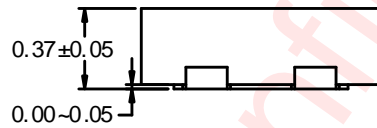

Side View

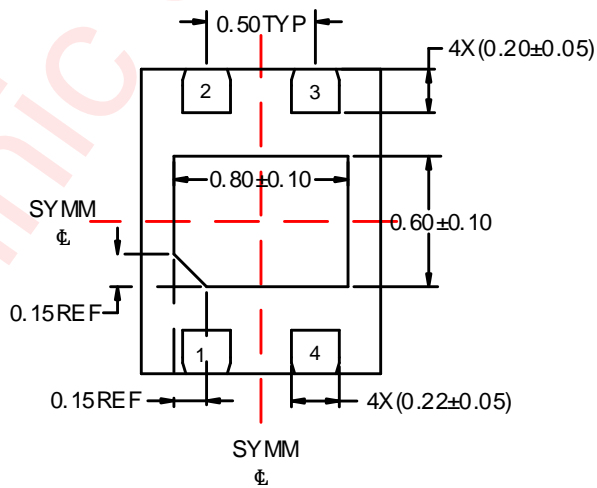

Bottom View

Unit: mm

Land Pattern Data

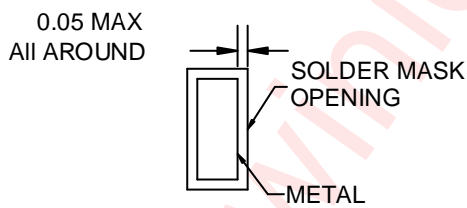
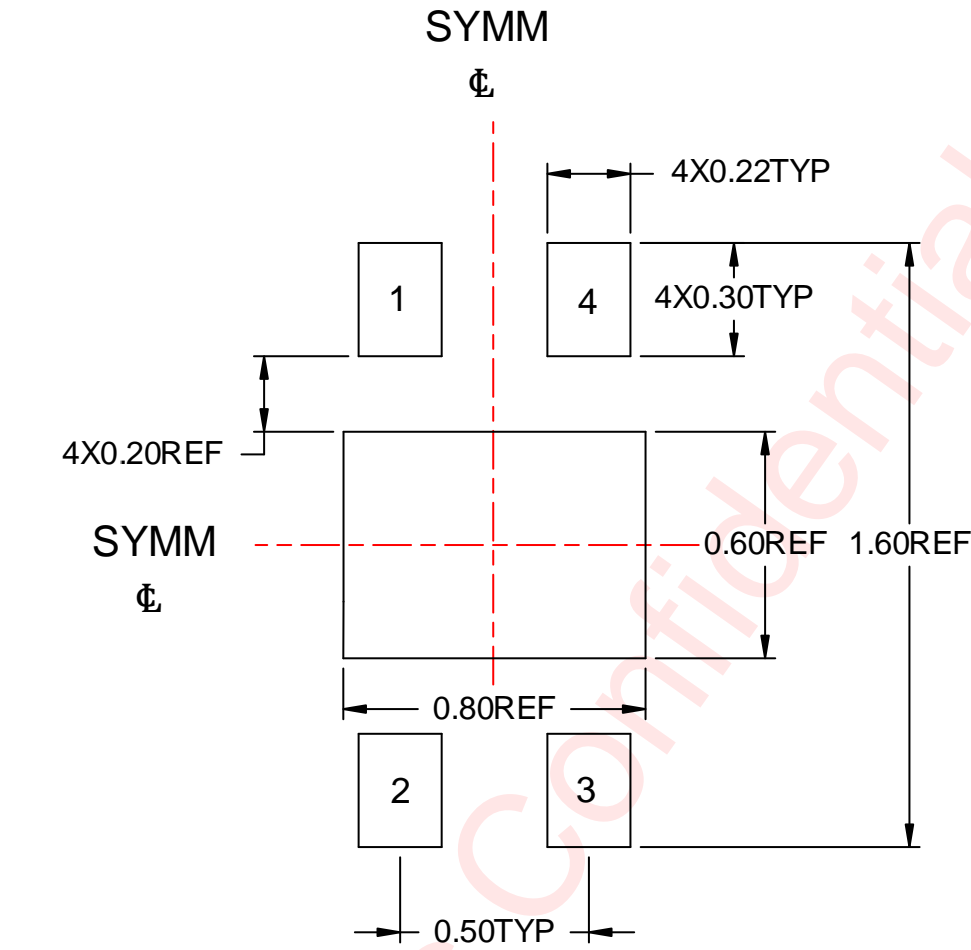

NON SOLDER MASK DEFINED

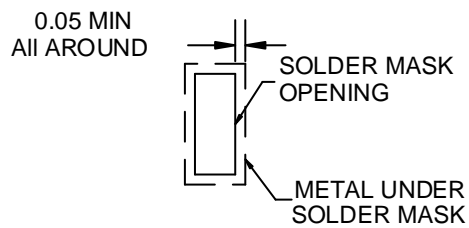

SOLDER MASK DEFINED

Unit: mm

Revision History

Version	Date	Change Record
V1.0	Jan. 2025	Officially released

Awinic Confidential

Disclaimer

All trademarks are the property of their respective owners. Information in this document is believed to be accurate and reliable. However, Shanghai AWINIC Technology Co., Ltd (AWINIC Technology) does not give any representations or warranties, expressed or implied, as to the accuracy or completeness of such information and shall have no liability for the consequences of use of such information.

AWINIC Technology reserves the right to make changes to information published in this document, including without limitation specifications and product descriptions, at any time and without notice. Customers shall obtain the latest relevant information before placing orders and shall verify that such information is current and complete. This document supersedes and replaces all information supplied prior to the publication hereof.

AWINIC Technology products are not designed, authorized or warranted to be suitable for use in medical, military, aircraft, space or life support equipment, nor in applications where failure or malfunction of an AWINIC Technology product can reasonably be expected to result in personal injury, death or severe property or environmental damage. AWINIC Technology accepts no liability for inclusion and/or use of AWINIC Technology products in such equipment or applications and therefore such inclusion and/or use is at the customer's own risk.

Applications that are described herein for any of these products are for illustrative purposes only. AWINIC Technology makes no representation or warranty that such applications will be suitable for the specified use without further testing or modification.

All products are sold subject to the general terms and conditions of commercial sale supplied at the time of order acknowledgement.

Nothing in this document may be interpreted or construed as an offer to sell products that is open for acceptance or the grant, conveyance or implication of any license under any copyrights, patents or other industrial or intellectual property rights.

Reproduction of AWINIC information in AWINIC data books or data sheets is permissible only if reproduction is without alteration and is accompanied by all associated warranties, conditions, limitations, and notices. AWINIC is not responsible or liable for such altered documentation. Information of third parties may be subject to additional restrictions.

Resale of AWINIC components or services with statements different from or beyond the parameters stated by AWINIC for that component or service voids all express and any implied warranties for the associated AWINIC component or service and is an unfair and deceptive business practice. AWINIC is not responsible or liable for any such statements.