

Precision OCXO OH4 Series



2111 Comprehensive Drive
Aurora, Illinois 60505
Phone: 630-851-4722
Fax: 630-851-5040
www.conwin.com

Description:

The Connor-Winfield OH4 Series, 14 Pin DIP Oven Stabilized Crystal Controlled Oscillators (OCXO) series, and Oven Stabilized Crystal Controlled Voltage Controlled Oscillators (OCVCXO) series, are designed for use in applications requiring stabilities of ± 5 ppb to ± 100 ppb. The OH4 series is also designed for compliance to ITU-T G.8262 Options 1 and 2, and ITU-T G.8263.



Features:

- OCXO - Fixed Frequency
- OCVCXO - Voltage Controlled
- Frequencies Range: 6.4 MHz to 40 MHz
Higher Frequencies available upon request
- 3.3V or 5.0V Operation
- LVCMOS, HCMOS or Sinewave Output
- Frequency Stabilities Available:
 ± 5 ppb; ± 10 ppb; ± 20 ppb; ± 25 ppb
 ± 50 ppb, or ± 100 ppb
- Temperature Ranges Available:
0 to 70°C, -20 to 70°C, -20 to 75°C,
-40 to 70°C, or -40 to 85°C
- Low Phase Noise
- 14 Pin DIP Package
- RoHS Compliant / Lead Free

Pin Connections

Pin Function
1: OCXO - N/C OCVCXO - Voltage Control
7: Ground (Case)
8: Output
14: Vcc

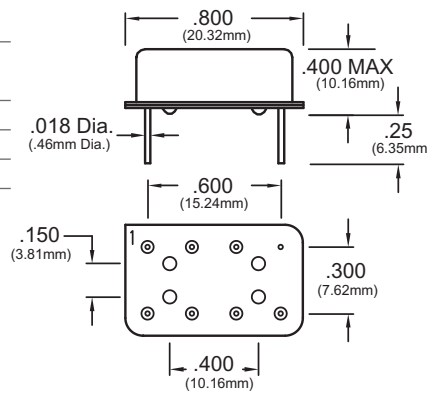

14 Pin DIP Package

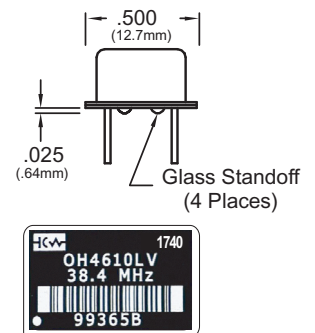

Dimensional Tolerance:
 $\pm .005$ (.127mm)
 $\pm .02$ (.508mm)

Ordering Information

OH4	5	10	L	F	-010.0M														
<table border="1"> <tr> <th>Oscillator Type</th> <th>Package Type</th> </tr> <tr> <td>Precision Frequency Std OCXO or OCVCXO</td> <td>OH4 = 14 Pin DIP</td> </tr> </table>	Oscillator Type	Package Type	Precision Frequency Std OCXO or OCVCXO	OH4 = 14 Pin DIP	<table border="1"> <tr> <th>Temperature Range</th> </tr> <tr> <td>5 = 0 to 70°C 6 = -40 to 85°C 7 = -20 to 70°C 8 = -40 to 70°C 9 = -20 to 75°C</td> </tr> </table>	Temperature Range	5 = 0 to 70°C 6 = -40 to 85°C 7 = -20 to 70°C 8 = -40 to 70°C 9 = -20 to 75°C	<table border="1"> <tr> <th>Frequency Stability</th> </tr> <tr> <td>*05 = ± 5 ppb 10 = ± 10 ppb 20 = ± 20 ppb 25 = ± 25 ppb 50 = ± 50 ppb 100 = ± 100 ppb</td> </tr> </table>	Frequency Stability	*05 = ± 5 ppb 10 = ± 10 ppb 20 = ± 20 ppb 25 = ± 25 ppb 50 = ± 50 ppb 100 = ± 100 ppb	<table border="1"> <tr> <th>Supply Voltage / Output</th> </tr> <tr> <td>L = 3.3Vdc / LVCMOS H = 5.0Vdc / HCMOS S = 5.0Vdc / Sinewave R = 3.3Vdc / Sinewave</td> </tr> </table>	Supply Voltage / Output	L = 3.3Vdc / LVCMOS H = 5.0Vdc / HCMOS S = 5.0Vdc / Sinewave R = 3.3Vdc / Sinewave	<table border="1"> <tr> <th>Output</th> </tr> <tr> <td>F = OCXO (Fixed Freq.) V = OCVCXO (Voltage Controlled)</td> </tr> </table>	Output	F = OCXO (Fixed Freq.) V = OCVCXO (Voltage Controlled)	<table border="1"> <tr> <th>Output Frequency</th> </tr> <tr> <td>M = MHz xxx.xxM</td> </tr> </table>	Output Frequency	M = MHz xxx.xxM
Oscillator Type	Package Type																		
Precision Frequency Std OCXO or OCVCXO	OH4 = 14 Pin DIP																		
Temperature Range																			
5 = 0 to 70°C 6 = -40 to 85°C 7 = -20 to 70°C 8 = -40 to 70°C 9 = -20 to 75°C																			
Frequency Stability																			
*05 = ± 5 ppb 10 = ± 10 ppb 20 = ± 20 ppb 25 = ± 25 ppb 50 = ± 50 ppb 100 = ± 100 ppb																			
Supply Voltage / Output																			
L = 3.3Vdc / LVCMOS H = 5.0Vdc / HCMOS S = 5.0Vdc / Sinewave R = 3.3Vdc / Sinewave																			
Output																			
F = OCXO (Fixed Freq.) V = OCVCXO (Voltage Controlled)																			
Output Frequency																			
M = MHz xxx.xxM																			

* ± 5 ppb stability only available for 0 - 70°C or -20 to 70°C





Absolute Maximum Ratings

Parameter	Minimum	Nominal	Maximum	Units	Notes
Storage Temperature	-55	-	125	°C	
Supply Voltage (Vcc)					
3.3V LVC MOS	-0.5	-	4.5	Vdc	
5.0V HCMOS / Sinewave	-0.5	-	7.0	Vdc	
Control Voltage (Vc)					
3.3V LVC MOS	-0.5	-	4.5	Vdc	
5.0V HCMOS / Sinewave	-0.5	-	7.0	Vdc	

Operating Specifications

Parameter	Minimum	Nominal	Maximum	Units	Notes
Frequency Calibration	-0.3	-	0.3	ppm	1, 4, 9,
Frequency Stability	*05: ±5; 10: ±10; 20: ±20; 50: ±50; 100: ±100			ppb	2
Frequency vs Change in Supply Voltage	-10	-	10	ppb	3
Aging Daily	-5	-	5	ppb	4
Aging 1st Year	-0.3	-	0.3	ppm	
Total Frequency Tolerance (20 years)	-1.5	-	1.5	ppm	5, 10
Supply Voltage (Vcc)					
3.3V LVC MOS	3.13	3.3	3.47	Vdc	
5.0V HCMOS / Sinewave	4.75	5.0	5.25	Vdc	
Supply Power (0 to 70°C)	-	-	1.4	Watts	
Supply Power (-40 to 85°C)	-	-	2.2	Watts	
Phase Jitter (BW = 10KHz to Fo/2)	-	-	1	ps RMS	
Period Jitter	-	-	5	ps RMS	
Allan Variance (1 second)	-	5.0E-11	-		
SSB Phase Noise at 10Hz offset	-	-100	-	dbc/Hz	6
SSB Phase Noise at 100Hz offset	-	-120	-	dbc/Hz	6
SSB Phase Noise at 1kHz offset	-	-140	-	dbc/Hz	6
SSB Phase Noise at 10kHz offset	-	-150	-	dbc/Hz	6
Start-Up Time Oscillator	-	-	35	ms	
Warm-Up Time	-	-	3	Minutes	7

OCVCXO Characteristics

Parameter	Minimum	Nominal	Maximum	Units	Notes
Control Voltage Range:(Vc)					
3.3V LVC MOS	0.30	1.65	3.0	Vdc	
5.0V HCMOS / Sinewave	0.50	2.50	4.50	Vdc	
Frequency					
3.3V LVC MOS at Vc=0.3 Vdc	-	-7	-5	ppm	8
3.3V LVC MOS at Vc=3.0 Vdc	5	7	-	ppm	8
5.0V HCMOS /Sinewave at Vc=0.5Vdc	-	-7	-5	ppm	8
5.0V HCMOS /Sinewave at Vc=4.5Vdc	5	7	-	ppm	8
Slope of Frequency Adjust					
3.3V LVC MOS	3.7	-	-	ppm/V	
5.0V HCMOS /Sinewave	2.5	-	-	ppm/V	
Input Impedance	100K	-	-	Ohms	

- Initial calibration @ 25C. OCVCXO model Vc = Nominal.
- Frequency stability vs. Change in temperature, referenced to 25C.
- Frequency stability per 5% change in supply voltage.
- At the time of shipment after 48 hours of operation.
- Inclusive of calibration, operating temperature range, supply voltage change, shock and vibration 20 years aging, OCVCXO models Vc = Nominal.
- Typical phase noise, results will vary depending on center frequency. The phase noise shown are typical for 20 MHz.
- Measured @ 25C, within 3 minutes, the unit will be within +/-0.1ppm of its reference frequency, measured after 30 minutes of continuous operation at a stable 25C.
- OCVCXO models pullability referenced to Fo @ 25°C, Positive Transfer Characteristics
- Initial calibration @ 25C. OCVCXO model Vc = Nominal.
- Inclusive of calibration, operating temperature range, supply voltage change, shock and vibration 20 years aging, OCVCXO models Vc = Nominal.

Bulletin	Cx259
Page	2 of 4
Revision	07
Date	15 Oct 2019

LVC MOS Output Characteristics

Parameter	Minimum	Nominal	Maximum	Units	Notes
Load	-	15	-	pF	
Voltage: 3.3V LVC MOS					
High (Voh)	2.60	-	-	Vdc	
Low (Vol)	-	-	0.40	Vdc	
Voltage: 5.0V HCMOS					
High (Voh)	Vcc-0.5	-	-	Vdc	
Low (Vol)	-	-	0.40	Vdc	
Current					
High (Ioh)	-4	-	-	mA	
Low (Iol)	-	-	4	mA	
Duty Cycle at 50% of Vcc	45	50	55	%	
Rise / Fall Time: 10% to 90%	-	-	6.5	ns	

Sinewave Output Characteristics

Parameter	Minimum	Nominal	Maximum	Units	Notes
Load	-	50	-	Ohms	
Output Power					
(Vcc=3.3V)	3	-	-	dBm	
(Vcc=5.0V)	6	-	-	dBm	
Harmonics	-	-	-30	dBc	
Spurious	-	-	-80	dBc	

Package Characteristics

OH4-Series DIP Package

14 Pin DIP Hermetically Sealed Grounded Welded Package

14 Pin DIP Package Environmental Characteristics

ENVIRONMENTAL CHARACTERISTICS

Temperature Cycle: Per MIL-STD-883, Method 1010, Condition B. -55°C to 125°C, 300 cycles, 10 minute dwell, 1 minute transition.
Gross Leak Test: Per MIL-STD-202, Method 112, Condition D. No Bubbles in flourinert (FC-43) at 125°C ±5°C for 20 seconds

SOLDERING

Pin Solderability: Per MIL-STD-883, Method 2003. 8 hour steam age prior to 254°C ±5°C Solder on dip, 95% Coverage.
Resistance to Solder Heat: Per MIL-STD-202, Method 210, Condition C. Wave: Topside board-mount product. 260°C ±5°C for 20 seconds

MECHANICAL CHARACTERISTICS

Vibration: Per MIL-STD-202, Method 204, Condition A. 10G's peak, 10Hz to 500Hz, 15 minute cycles 12 times each perpendicular axis.
Shock: Per MIL-STD-202, Method 213, Condition F 1500G's, 0.5ms, half sine, 3 shocks per direction.
Moisture Resistance: Per MIL-STD-202, Method 106. 95% RH @ 65°C, 10 cycles 10°C to 65°C.

Test Circuit

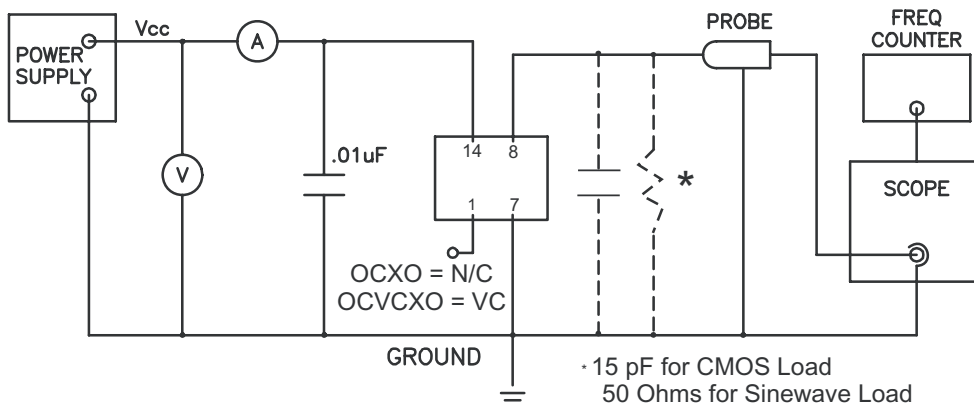

CMOS Output Waveform

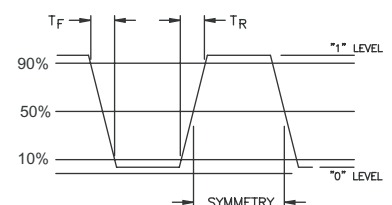

Bulletin	Cx259
Page	3 of 4
Revision	07
Date	15 Oct 2019

OH4610LF-020.0M MTIE per Stratum 3E (OCXO is covered)
Loop Bandwidth = 0.0016 Hz

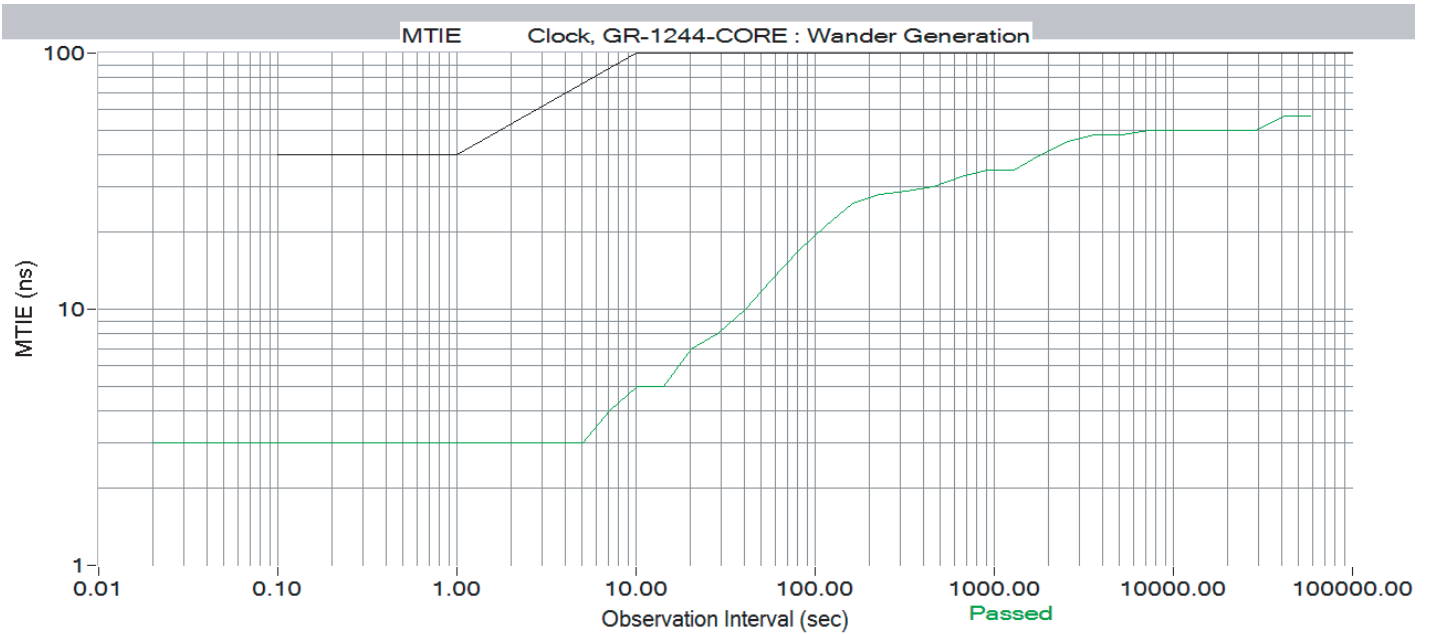

OH4610LF-020.0M TDEV per Stratum 3E (OCXO is covered)
Loop Bandwidth = 0.0016 Hz

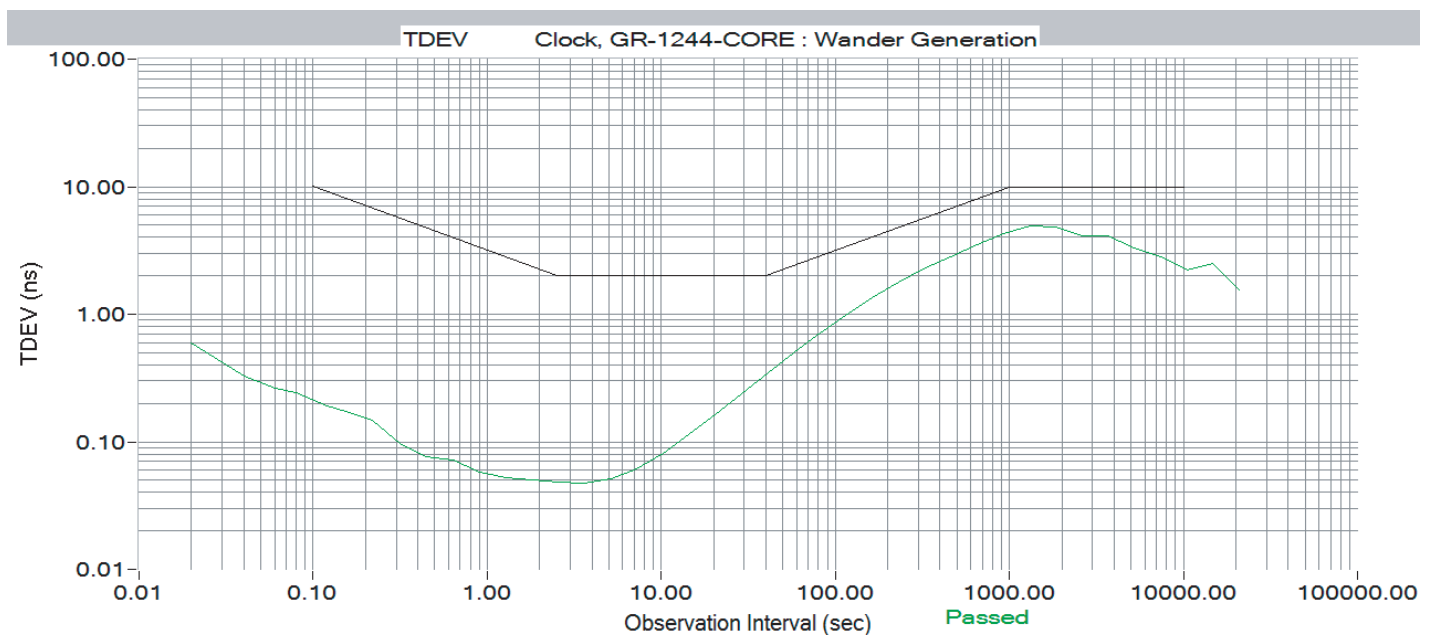

Revision History

Revision	Date	Note
00	09/30/14	New issue
06	08/08/19	Added ± 100 ppb Frequency Stability
07	10/15/19	Added ± 25 ppb Frequency Stability

Bulletin	Cx259
Page	4 of 4
Revision	07
Date	15 Oct 2019