

REACH & RoHS
COMPLIANT

| REV. | ECN / DESCRIPTION | BY | DATE |
|------|-------------------|----|------|
| | | | |

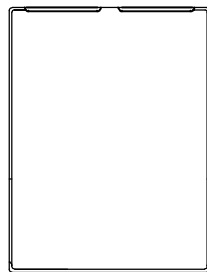

TOP VIEW

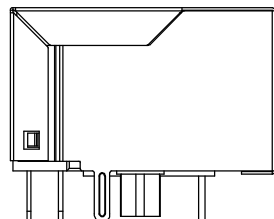

LEFT SIDE VIEW

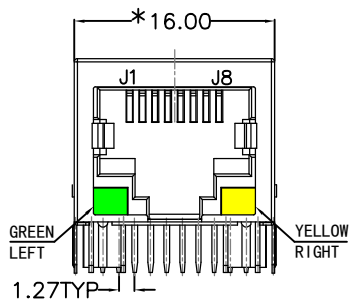

FRONT VIEW

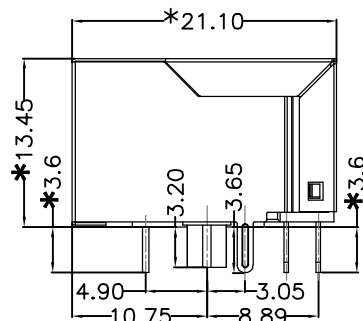

RIGHT SIDE VIEW

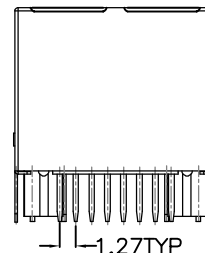

BACK VIEW

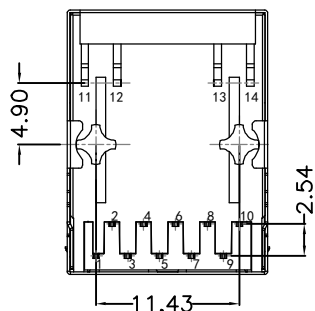

BOTTOM VIEW

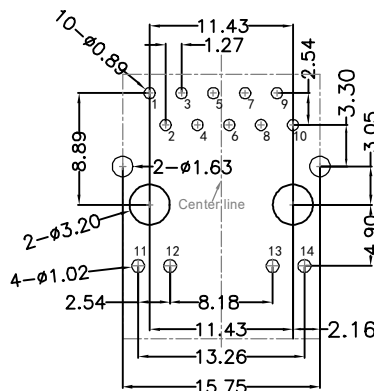

RECOMMENDED PCB LAYOUT
VIEWED FROM COMPONENT SIDE

MATERIAL:

HOUSING : PBT,UL94V-0,BLACK.
 TERMINALS BRACKET: PBT,UL94V-0,BLACK.
 SHIELD: C2680,T=0.20MM,NICKEL PLATING ON ALL AREA.
 TERMINAL: PHOSPHOR BRONZE C5210,T=0.35MM,
 6U" GOLD PLATING ON CONTACT AREA.

MECHANICAL:

DURABILITY : 750 CYCLES MIN.
 MATING FORCE : 23N MAX.
 OPERATING TEMPERATURE: -40°C~+85°C.
 STORAGE TEMPERATURE: -40°C~+85°C.
 ALL CRITICAL DIMENSIONS WITH "*"

深圳市富港科技有限公司

| | | | | | | |
|----------------------------------------|-------------------------------|-------------------|----------------------------------------|-----------------------|-------------------------|--------------------|
| TITLE: TAB-DOWN 1X1 10/100/1000BASE | SIZE A4 | UNITS MM[INCH] | GENERAL TOLERANCES UNLESS SPECIFIED | | APPROVED BY: | |
| | PART NO.: RJ-111Q066BA2A1D | SACLE 1:1 | REV A0 | x±0.35 .x±0.30 | x°±3.0° .x°±2.0° | CHECKED BY: |
| | REMARK: | SHEET 1/4 | | .xx±0.25 .xxx±0.10 | .xx°±1.5° .xxx°±1.0° | DESIGND BY: KYD |

REACH & RoHS
COMPLIANT

RECOMMENDED PANEL CUTOUT (REFERENCE ONLY):

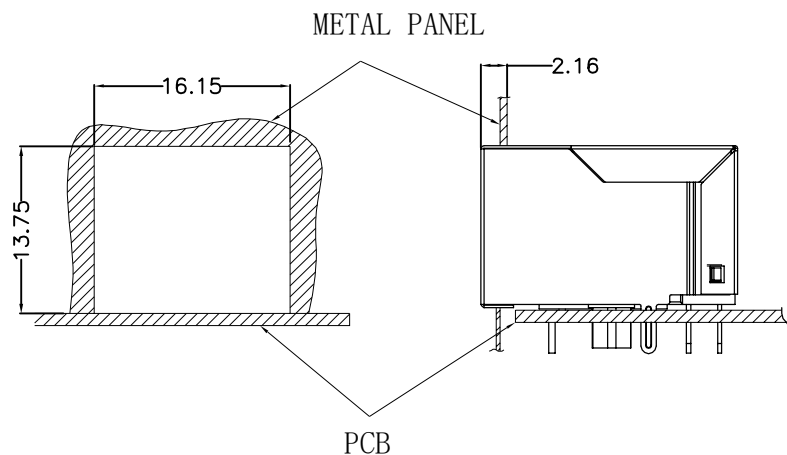

UNIT: MM / INCH
TOLERANCES: ± 0.10 / 0.004
REFERENCE ONLY

KEEP-OUT AREA (COMPONENT SIDE VIEW):

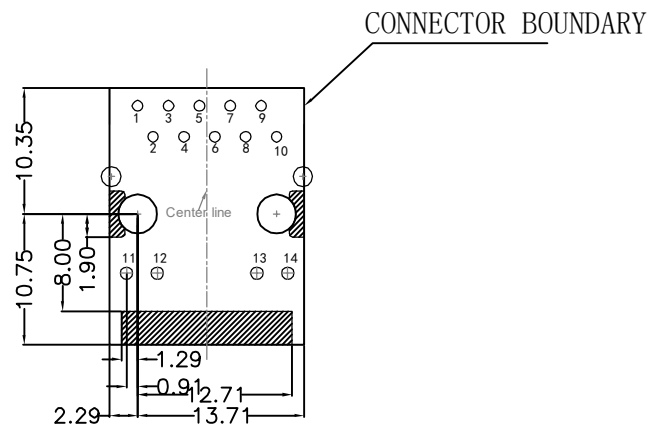

PLUG-IN SIDE

UNIT: MM / INCH
TOLERANCES: ± 0.10 / 0.004

深圳市富港科技有限公司

TITLE:
TAB-DOWN 1X1 10/100/1000BASE
PART NO.:
RJ-111Q066BA2A1D
REMARK:

| | | | |
|--------------|-------------------|----------------------------------------|----------------------------|
| SIZE A4 | UNITS MM[INCH] | GENERAL TOLERANCES UNLESS SPECIFIED | |
| SACLE 1:1 | REV A0 | $x \pm 0.35$ | $x^\circ \pm 3.0^\circ$ |
| SHEET 2/4 | | $.x \pm 0.30$ | $.x^\circ \pm 2.0^\circ$ |
| | | $.xx \pm 0.25$ | $.xx^\circ \pm 1.5^\circ$ |
| | | $.xxx \pm 0.10$ | $.xxx^\circ \pm 1.0^\circ$ |

APPROVED BY:
CHECKED BY:
DESIGN BY:

REACH & RoHS
COMPLIANT

| REV. | ECN / DESCRIPTION | BY | DATE |
|------|-------------------|----|------|
| | | | |

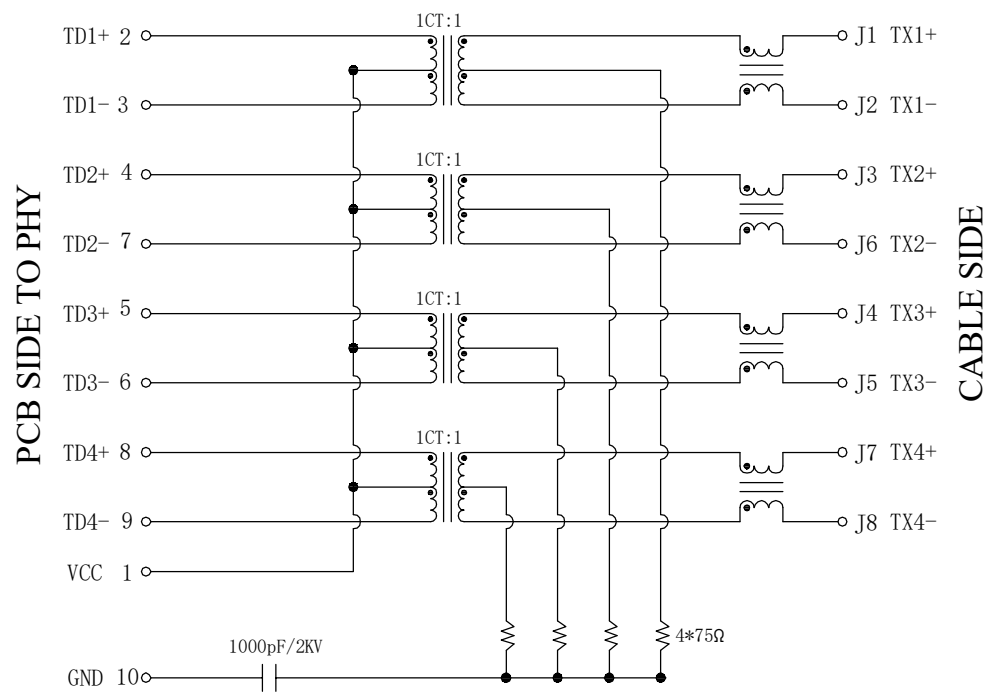

Electrical:

- Turn ratio: 2~3: J1~J2=1CT:1CT(±2%).
4~7: J3~J6=1CT:1CT(±2%).
5~6: J4~J5=1CT:1CT(±2%).
8~9: J7~J8=1CT:1CT(±2%).
- OCL: 350uH Min. at 100KHz 100mV 8mA DC.
- Insertion Loss: -1.0 dB Max 1~100MHz.
- Return loss: -18dB Min 1~30MHz;
-14dB Min 30~60MHz.
-12dB Min 60~80MHz.
-10dB Min 80~100MHz.
- Cross talk: -40dB Min 1~30MHz;
-35dB Min 30~60MHz;
-30dB Min 60~100MHz;
- CMR: -30dB Min 1~100MHz;
- Hi-Pot: 2250V DC 6S 1mA PRI TO SEC

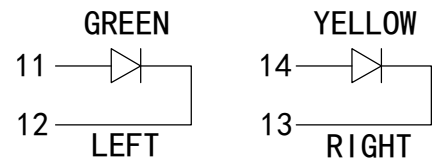

LED Specification

| Standard LED Color | LED Wavelength | Foward(A) | Foward(V) |
|--------------------|----------------|-----------|------------|
| Green | 568nm | 20mA | 1.85-2.45V |
| Yellow | 585nm | 20mA | 1.7-2.2V |

深圳市富港科技有限公司

| | | | | | |
|----------------------------------------|--------------|-------------------|----------------------------------------|------------|--------------|
| TITLE: TAB-DOWN 1X1 10/100/1000BASE | SIZE A4 | UNITS MM[INCH] | GENERAL TOLERANCES UNLESS SPECIFIED | | APPROVED BY: |
| PART NO.: RJ-111Q066BA2A1D | SACLE 1:1 | REV A0 | x±0.35 | x°±3.0° | CHECKED BY: |
| REMARK: | SHEET 3/4 | | .xx±0.25 | .xx°±1.5° | |
| | | | .xxx±0.10 | .xxx°±1.0° | DESIGND BY: |

REACH & RoHS
COMPLIANT

PROFILE OF WAVE SOLDER

| REV. | ECN / DESCRIPTION | BY | DATE |
|------|-------------------|----|------|
| | | | |

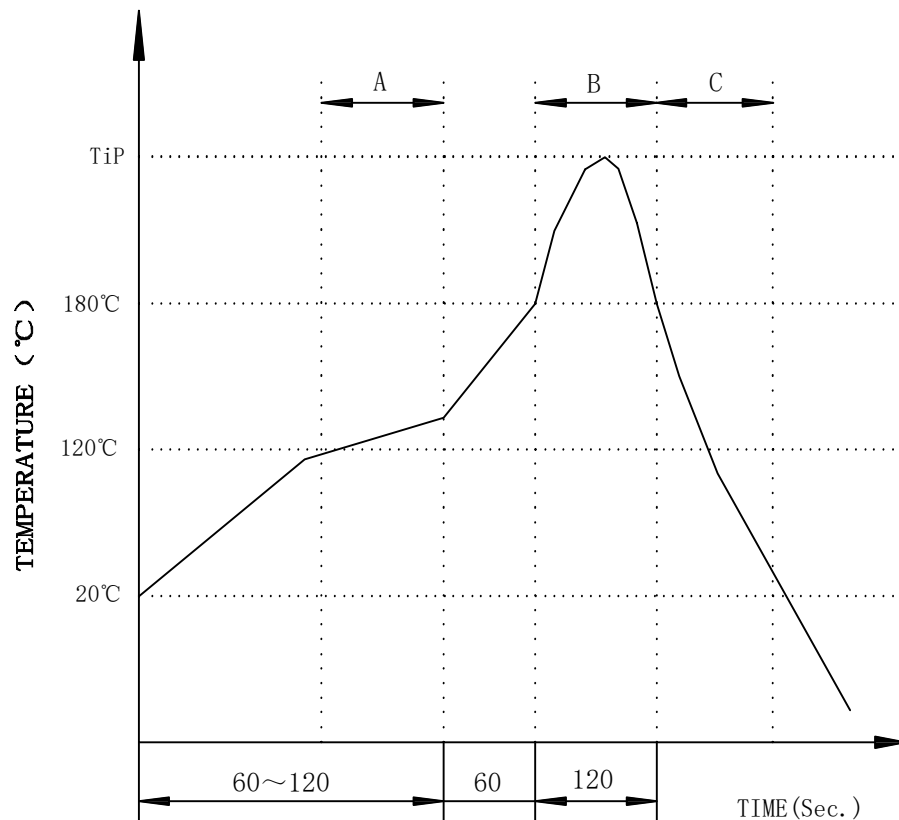

A.Preheating B.Soldering C.Gradual Cooling
 Tip temperature:260±5°C.
 Tip temperature time:5Sec Max.
 Tip melting point of Sn96.5/Ag3/Cu0.5:217°C.

Remarks: after wave soldering, the plastic
 positioning columns of the product which under the
 PCB will be slightly melted, but it won't affect its
 function.

深圳市富港科技有限公司

| | | | | | |
|----------------------------------------|--------------|-------------------|----------------------------------------|------------|--------------|
| TITLE: TAB-DOWN 1X1 10/100/1000BASE | SIZE A4 | UNITS MM[INCH] | GENERAL TOLERANCES UNLESS SPECIFIED | | APPROVED BY: |
| PART NO.: RJ-111Q066BA2A1D | SACLE 1:1 | REV A0 | x±0.35 | x°±3.0° | CHECKED BY: |
| REMARK: | SHEET 4/4 | | .xx±0.25 | .xx°±1.5° | |
| | | | .xxx±0.10 | .xxx°±1.0° | DESIGND BY: |