



Description

The EL3H7 is a photoelectric coupler composed of light-emitting diode and phototransistor. It is packaged in a 4-pin package.

Features

- Current transfer ratio(CTR:MIN.50% at $I_F=5\text{mA}, V_{CE}=5\text{V}$)
- High input-output isolation voltage ($V_{iso}=3,750\text{Vrms}$)
- Operating Temperature:-55°C~100°C
- RoHS

Applications

- Programmable controllers
- Switching power supply, intelligent meter
- Home appliances: such as air conditioners, fans, water heaters, etc

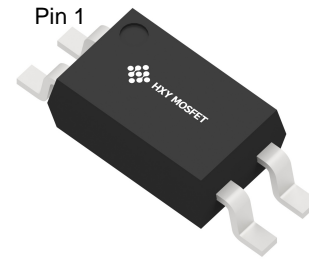

SSOP-4

Schematic

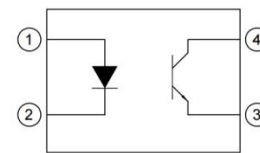

Pin Configuration

- 1 Anode
- 2 Cathode
- 3 Emitter
- 4 Collector

Absolute Ratings($T_{amb} = 25^\circ\text{C}$)

Parameter		Symbol	Values	Unit
Input	Forward Current	I_F	50	mA
	Reverse Voltage	V_R	6	V
	Power Dissipation	P_D	70	mW
	Derating factor (above $T_a = 90^\circ\text{C}$)		2.0	mW/°C
Output	Collector - Emitter Voltage	V_{CEO}	80	V
	Emitter - Collector Voltage	V_{ECO}	7	V
	Collector Current	I_C	50	mA
	Collector Power Dissipation	P_C	150	mW
	Derating factor (above $T_a = 70^\circ\text{C}$)		3.1	mW/°C
Operating temperature range		T_{op}	-55 ~ 110	°C
Storage temperature range		T_{stg}	-55 ~ 125	°C
Total Power consumption		$P(W)$	200	mW
Isolation Voltage ⁽¹⁾		V_{ISO}	3750	Vrms
Soldering Temperature ⁽²⁾		T_{sol}	260	°C

Notes:

(1). AC for 1 minute, R.H.= 40 ~ 60% R.H. In this test, pins 1, 2 are shorted together, and pins 3, 4 are shorted together.

(2).For 10 seconds



Electrical Characteristics (Ratings at 25°C)

Parameter		Symbol	Min.	Typ.	Max.	Unit	Conditon
Input	Forward Voltage	V_F	-	1.2	1.4	V	$I_F=20\text{mA}$
	Reverse Current	I_R	-	-	10	μA	$V_R=4\text{V}$
	Terminal Capacitance	C_t	-	30	250	pF	$V=0, f=1\text{KHz}$
Output	Collector Dark Current	I_{CEO}	-	-	100	nA	$V_{CE}=20\text{V}, I_F=0$
	Collector-Emitter Breakdown Voltage	BV_{CEO}	80			V	$I_C=0.1\text{mA}, I_F=0$
	Emitter-Collector Breakdown Voltage	BV_{ECO}	7			V	$I_E=10\mu\text{A}, I_F=0$
Collector-Emitter Saturation Voltage		$V_{CE(sat)}$		0.1	0.2	V	$I_F=20\text{mA}, I_C=1\text{mA}$
Isolation Resistance		R_{iso}	5×10^{10}	1×10^{11}	-	Ω	DC500V, 40 ~ 60% R.H.
Floating Capacitance		C_f		0.6	1	pF	$V=0, f=1\text{MHz}$
Cut-off Frequency		f_c		80		kHz	$V_{CE}=5\text{V}, I_C=2\text{mA}, R_L=100\Omega, -3\text{dB}$
Response Time (Rise)		t_r		4	18	μs	$V_{CE}=2\text{V}, I_C=2\text{mA}, R_L=100\Omega,$
Response Time (Fall)		t_f		3	18	μs	

Rank Table Of Current Transfer Ratio (CTR= $I_C/I_F \times 100\%$)

Rank Code	Symbol	Min	Max	Conditon
NONE	CTR	50	600	$I_F=5\text{mA}, V_{CE}=5\text{V}, T_a=25^\circ\text{C}$
A		80	160	
B		130	260	
C		200	400	
D		300	600	



Characteristics Curves

Fig.1 Relative Current Transfer Ratio vs. Forward Current

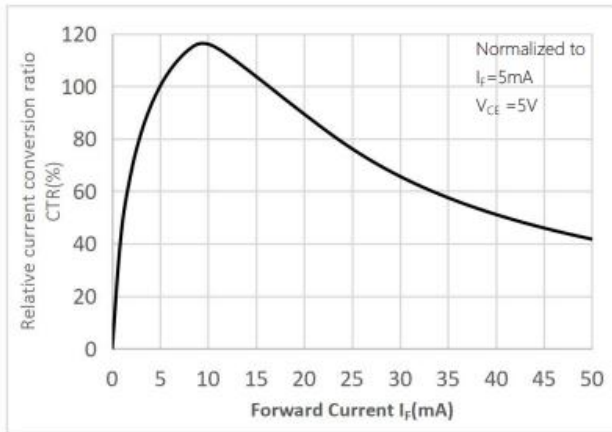

Fig.2 Forward Current vs. Forward Voltage

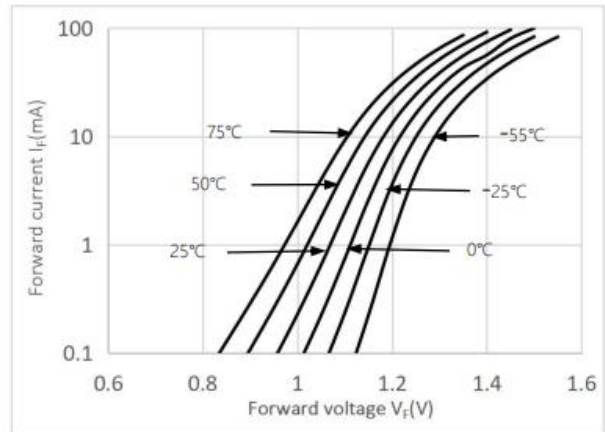

Fig.3 Collector Current vs. Collector-emitter Voltage

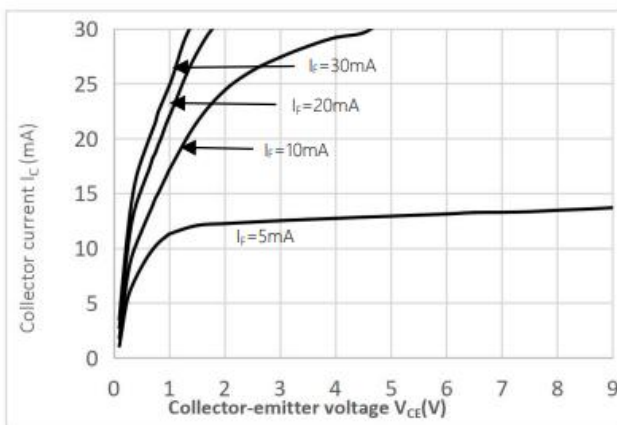

Fig.4 Relative Current Transfer Ratio vs. Ambient Temperature

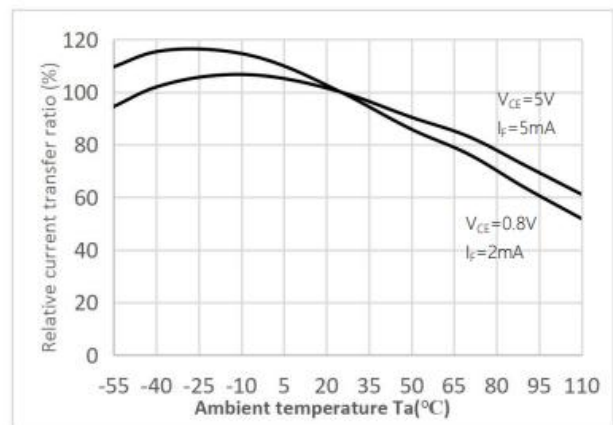

Fig.5 Collector-emitter Saturation Voltage vs. Ambient Temperature

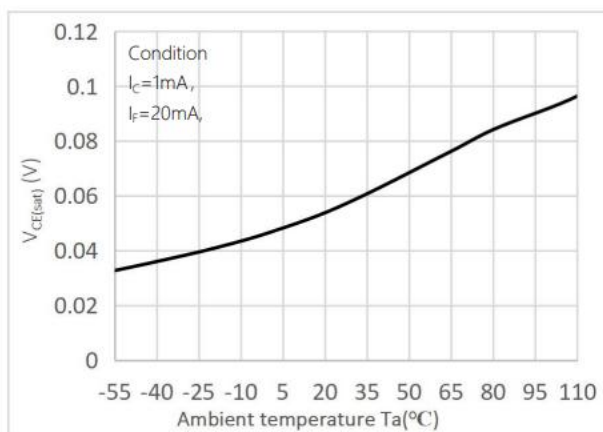

Fig.6 Collector Dark Current vs Ambient Temperature

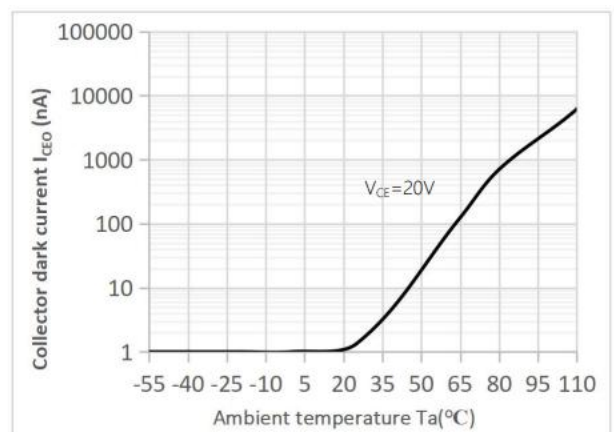



Fig.7 Response Time vs. Load Resistance

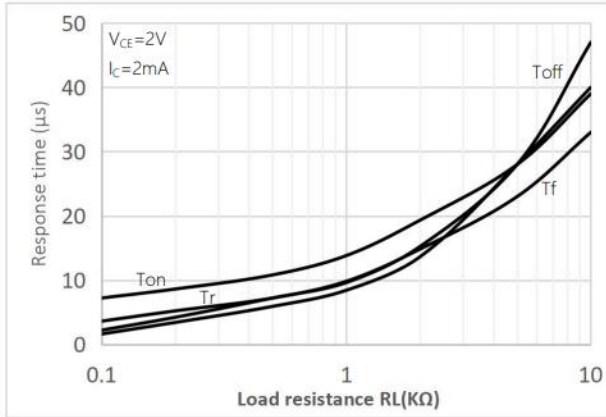

Fig.8 Frequency Response

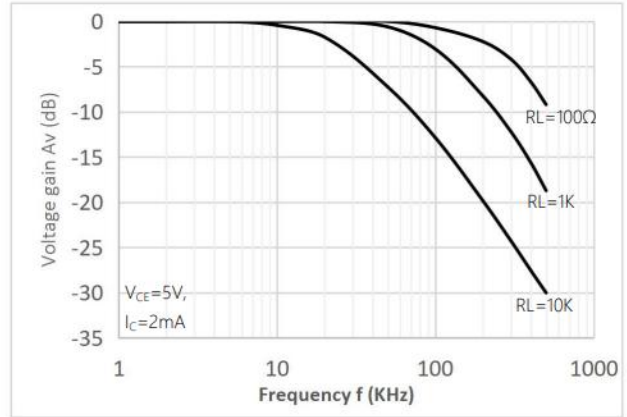

Fig.9 Collector-emitter Saturation Voltage vs Forward Current

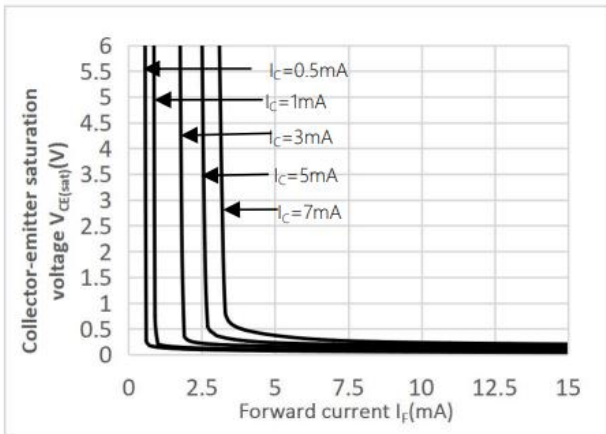
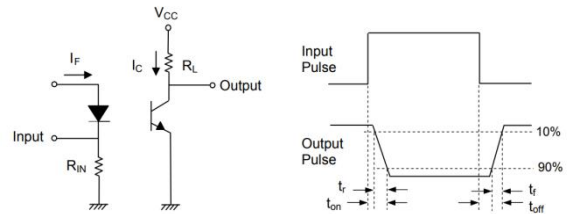
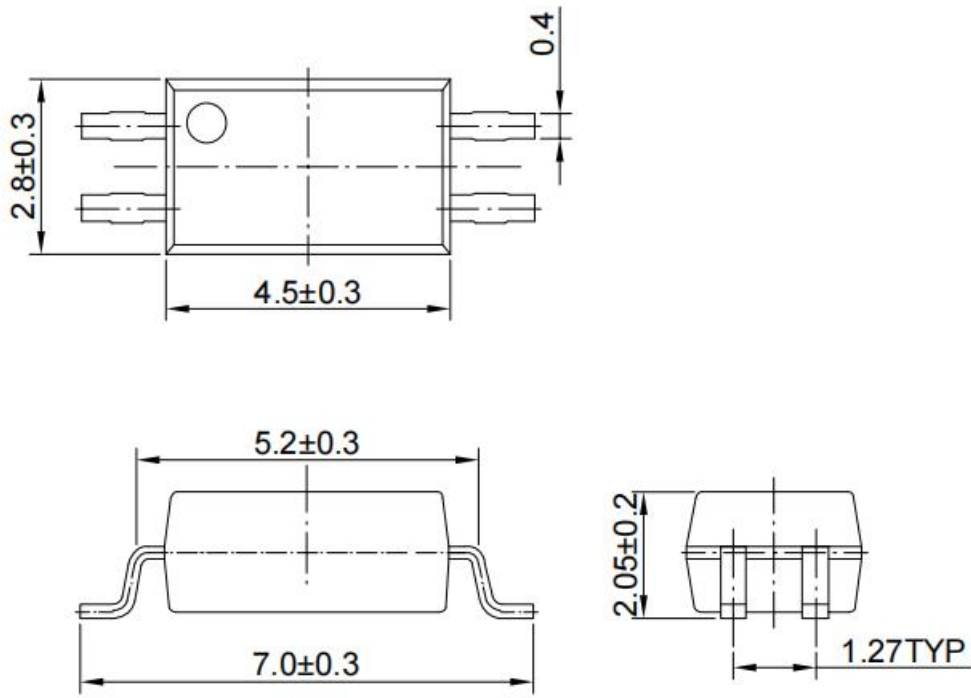

Fig.10 Switching Time Test Circuit & Waveforms





Outline Dimension



Unit: mm
Tolerance: ± 0.1 mm

Recommended solder pad Design

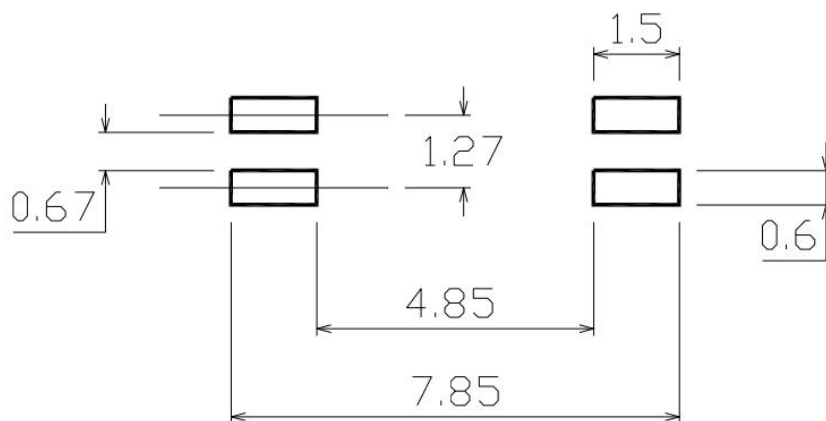

Unit: mm
Tolerance: ± 0.1 mm



Temperature Profile Of Soldering

1.IR Reflow soldering (JEDEC-STD-020D compliant)

Profile item	Conditon
Preheat	
-Temperature Min (TSmin)	150°C
-Temperature Max (TSmax)	200°C
-Time (min to max) (ts)	90 ± 30 sec
Soldering zone	
-Temperature (TL)	217°C
-Time (tL)	60-150 sec
Peak Temperature (TP)	260°C
-Time (TP-5°C to TP) (ts)	30 sec
Ramp-up rate	3°C / sec max
Ramp-down rate	3~6°C/ sec

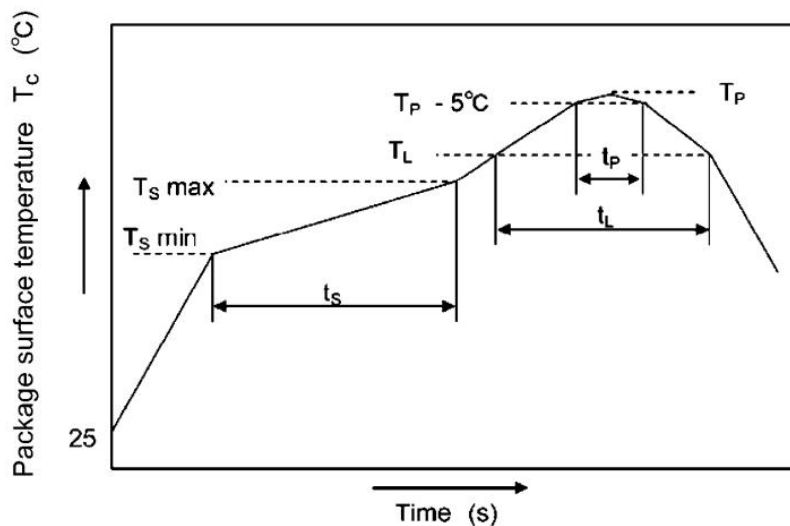

Notes:

One time soldering reflow is recommended within the condition of temperature and time profile shown below.
Do not solder more than three times.



2. Wave soldering (JEDEC22A111 compliant)

One time soldering is recommended within the condition.

Temperature: $260 \pm 0/-5^\circ\text{C}$.

Time: 10 sec.

Preheat temperature: 25 to 140°C .

Preheat time: 30 to 80 sec.

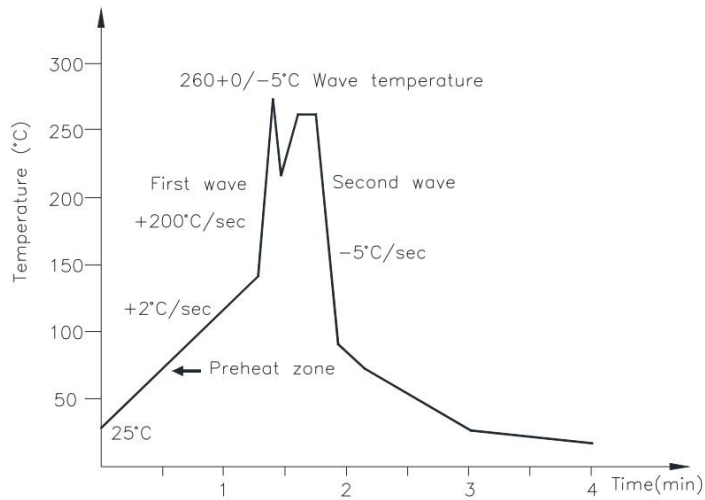

3. Hand soldering by soldering iron

Allow single lead soldering in every single process. One time soldering is recommended.

Temperature: $380 \pm 0/-5^\circ\text{C}$

Time: 3 sec max.



Attention

- Any and all HUA XUAN YANG ELECTRONICS products described or contained herein do not have specifications that can handle applications that require extremely high levels of reliability, such as life-support systems, aircraft's control systems, or other applications whose failure can be reasonably expected to result in serious physical and/or material damage. Consult with your HUA XUAN YANG ELECTRONICS representative nearest you before using any HUA XUAN YANG ELECTRONICS products described or contained herein in such applications.
- HUA XUAN YANG ELECTRONICS assumes no responsibility for equipment failures that result from using products at values that exceed, even momentarily, rated values (such as maximum ratings, operating condition ranges, or other parameters) listed in products specifications of any and all HUA XUAN YANG ELECTRONICS products described or contained herein.
- Specifications of any and all HUA XUAN YANG ELECTRONICS products described or contained herein stipulate the performance, characteristics, and functions of the described products in the independent state, and are not guarantees of the performance, characteristics, and functions of the described products as mounted in the customer's products or equipment. To verify symptoms and states that cannot be evaluated in an independent device, the customer should always evaluate and test devices mounted in the customer's products or equipment.
- HUA XUAN YANG ELECTRONICS CO.,LTD. strives to supply high-quality high-reliability products. However, any and all semiconductor products fail with some probability. It is possible that these probabilistic failures could give rise to accidents or events that could endanger human lives, that could give rise to smoke or fire, or that could cause damage to other property. When designing equipment, adopt safety measures so that these kinds of accidents or events cannot occur. Such measures include but are not limited to protective circuits and error prevention circuits for safe design, redundant design, and structural design.
- In the event that any or all HUA XUAN YANG ELECTRONICS products(including technical data, services) described or contained herein are controlled under any of applicable local export control laws and regulations, such products must not be exported without obtaining the export license from the authorities concerned in accordance with the above law.
- No part of this publication may be reproduced or transmitted in any form or by any means, electronic or mechanical, including photocopying and recording, or any information storage or retrieval system, or otherwise, without the prior written permission of HUA XUAN YANG ELECTRONICS CO.,LTD.
- Information (including circuit diagrams and circuit parameters) herein is for example only ; it is not guaranteed for volume production. HUA XUAN YANG ELECTRONICS believes information herein is accurate and reliable, but no guarantees are made or implied regarding its use or any infringements of intellectual property rights or other rights of third parties.
- Any and all information described or contained herein are subject to change without notice due to product/technology improvement, etc. When designing equipment, refer to the "Delivery Specification" for the HUA XUAN YANG ELECTRONICS product that you intend to use.