

Features

- Ultra Low On-Resistance
- $V_{DS}=100V$
- $R_{DS(ON)}$ (at $V_{GS}=10V$) < 160m Ω
- $R_{DS(ON)}$ (at $V_{GS} = 5V$) < 165m Ω
- Simulation Models
- Temperature Compensated PSPICE® and SABER™
- Electrical Models
- Spice and SABER Thermal Impedance Models
- Peak Current vs Pulse Width Curve
- UIS Rating Curve
- Switching Time vs R_{GS} Curves

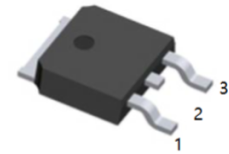

1.G 2.D 3.S
TO-252(DPAK) top view

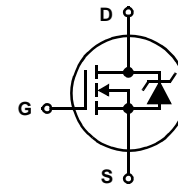

Absolute Maximum Ratings $T_C = 25^\circ C$, Unless Otherwise Specified

		HUF76609D3	UNITS
Drain to Source Voltage (Note 1)	V_{DSS}	100	V
Drain to Gate Voltage ($R_{GS} = 20k\Omega$) (Note 1)	V_{DGR}	100	V
Gate to Source Voltage	V_{GS}	± 16	V
Drain Current			
Continuous ($T_C = 25^\circ C$, $V_{GS} = 5V$)	I_D	10	A
Continuous ($T_C = 25^\circ C$, $V_{GS} = 10V$) (Figure 2)	I_D	10	A
Continuous ($T_C = 100^\circ C$, $V_{GS} = 5V$)	I_D	7	A
Continuous ($T_C = 100^\circ C$, $V_{GS} = 4.5V$) (Figure 2)	I_D	7	A
Pulsed Drain Current	I_{DM}	Figure 4	
Pulsed Avalanche Rating	UIS	Figures 6, 17, 18 Power	
Dissipation	P_D	49	W
Derate Above $25^\circ C$		0.327	W/ $^\circ C$
Operating and Storage Temperature	T_J, T_{STG}	-55 to 175	$^\circ C$
Maximum Temperature for Soldering			
Leads at 0.063in (1.6mm) from Case for 10s	T_L	300	$^\circ C$
Package Body for 10s, See Techbrief TB334	T_{pkg}	260	$^\circ C$

NOTE:

1. $T_J = 25^\circ C$ to $150^\circ C$.

Electrical Specifications $T_C = 25^\circ\text{C}$, Unless Otherwise Specified

PARAMETER	SYMBOL	TEST CONDITIONS	MIN	TYP	MAX	UNITS	
OFF STATE SPECIFICATIONS							
Drain to Source Breakdown Voltage	BV_{DSS}	$I_D = 250\mu\text{A}$, $V_{GS} = 0\text{V}$ (Figure 12)	100			V	
		$I_D = 250\mu\text{A}$, $V_{GS} = 0\text{V}$, $T_C = -40^\circ\text{C}$ (Figure 12)	90			V	
Zero Gate Voltage Drain Current	I_{DSS}	$V_{DS} = 95\text{V}$, $V_{GS} = 0\text{V}$			1	μA	
		$V_{DS} = 90\text{V}$, $V_{GS} = 0\text{V}$, $T_C = 150^\circ\text{C}$			250	μA	
Gate to Source Leakage Current	I_{GSS}	$V_{GS} = \pm 16\text{V}$			± 100	nA	
ON STATE SPECIFICATIONS							
Gate to Source Threshold Voltage	$V_{GS(TH)}$	$V_{GS} = V_{DS}$, $I_D = 250\mu\text{A}$ (Figure 11)	1		3	V	
Drain to Source On Resistance	$r_{DS(ON)}$	$I_D = 10\text{A}$, $V_{GS} = 10\text{V}$ (Figures 9, 10)		130	150	$\text{m}\Omega$	
		$I_D = 7\text{A}$, $V_{GS} = 5\text{V}$ (Figure 9)		135	160	$\text{m}\Omega$	
		$I_D = 7\text{A}$, $V_{GS} = 4.5\text{V}$ (Figure 9)		140	161	$\text{m}\Omega$	
THERMAL SPECIFICATIONS							
Thermal Resistance Junction to Case	$R_{\theta JC}$	TO-252			3.06	$^\circ\text{C}/\text{W}$	
Thermal Resistance Junction to Ambient	$R_{\theta JA}$				100	$^\circ\text{C}/\text{W}$	
SWITCHING SPECIFICATIONS ($V_{GS} = 4.5\text{V}$)							
Turn-On Time	t_{ON}	$V_{DD} = 50\text{V}$, $I_D = 7\text{A}$ $V_{GS} = 4.5\text{V}$, $R_{GS} = 20\Omega$ (Figures 15, 21, 22)			77	ns	
Turn-On Delay Time	$t_{d(ON)}$			10		ns	
Rise Time	t_r			41		ns	
Turn-Off Delay Time	$t_{d(OFF)}$			30		ns	
Fall Time	t_f			28		ns	
Turn-Off Time	t_{OFF}				87	ns	
SWITCHING SPECIFICATIONS ($V_{GS} = 10\text{V}$)							
Turn-On Time	t_{ON}	$V_{DD} = 50\text{V}$, $I_D = 10\text{A}$ $V_{GS} = 10\text{V}$, $R_{GS} = 24\Omega$ (Figures 16, 21, 22)			36	ns	
Turn-On Delay Time	$t_{d(ON)}$			6		ns	
Rise Time	t_r			18		ns	
Turn-Off Delay Time	$t_{d(OFF)}$			55		ns	
Fall Time	t_f			39		ns	
Turn-Off Time	t_{OFF}				141	ns	
GATE CHARGE SPECIFICATIONS							
Total Gate Charge	$Q_{g(TOT)}$	$V_{GS} = 0\text{V}$ to 10V	$V_{DD} = 50\text{V}$, $I_D = 7\text{A}$, $I_{g(REF)} = 1.0\text{mA}$ (Figures 14, 19, 20)		13	16	nC
Gate Charge at 5V	$Q_{g(5)}$	$V_{GS} = 0\text{V}$ to 5V			7.3	8.8	nC
Threshold Gate Charge	$Q_{g(TH)}$	$V_{GS} = 0\text{V}$ to 1V			0.5	0.6	nC
Gate to Source Gate Charge	Q_{gs}				1.4		nC
Gate to Drain "Miller" Charge	Q_{gd}				3.4		nC
CAPACITANCE SPECIFICATIONS							
Input Capacitance	C_{ISS}	$V_{DS} = 25\text{V}$, $V_{GS} = 0\text{V}$, $f = 1\text{MHz}$ (Figure 13)		425		pF	
Output Capacitance	C_{OSS}			75		pF	
Reverse Transfer Capacitance	C_{RSS}			22		pF	

Source to Drain Diode Specifications

PARAMETER	SYMBOL	TEST CONDITIONS	MIN	TYP	MAX	UNITS
Source to Drain Diode Voltage	V_{SD}	$I_{SD} = 7\text{A}$			1.25	V
		$I_{SD} = 4\text{A}$			1.0	V
Reverse Recovery Time	t_{rr}	$I_{SD} = 7\text{A}$, $dI_{SD}/dt = 100\text{A}/\mu\text{s}$			92	ns
Reverse Recovered Charge	Q_{RR}	$I_{SD} = 7\text{A}$, $dI_{SD}/dt = 100\text{A}/\mu\text{s}$			273	nC

Typical Performance Curves

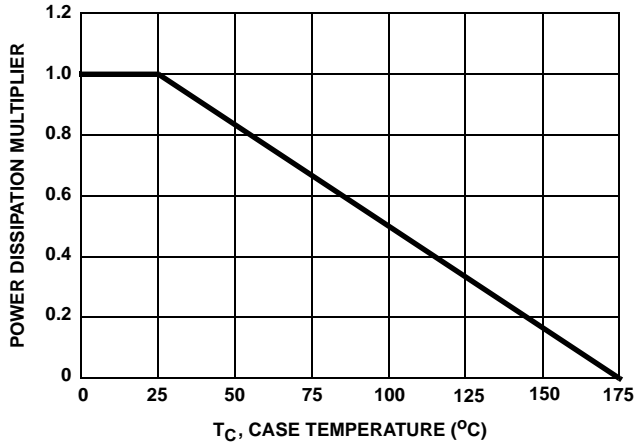

FIGURE 1. NORMALIZED POWER DISSIPATION vs CASE TEMPERATURE

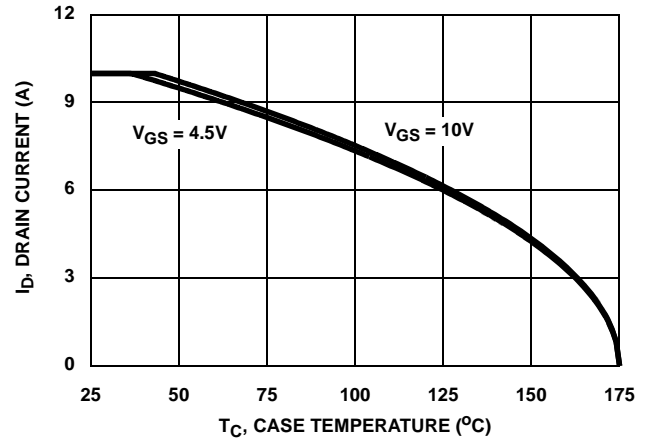

FIGURE 2. MAXIMUM CONTINUOUS DRAIN CURRENT vs CASE TEMPERATURE

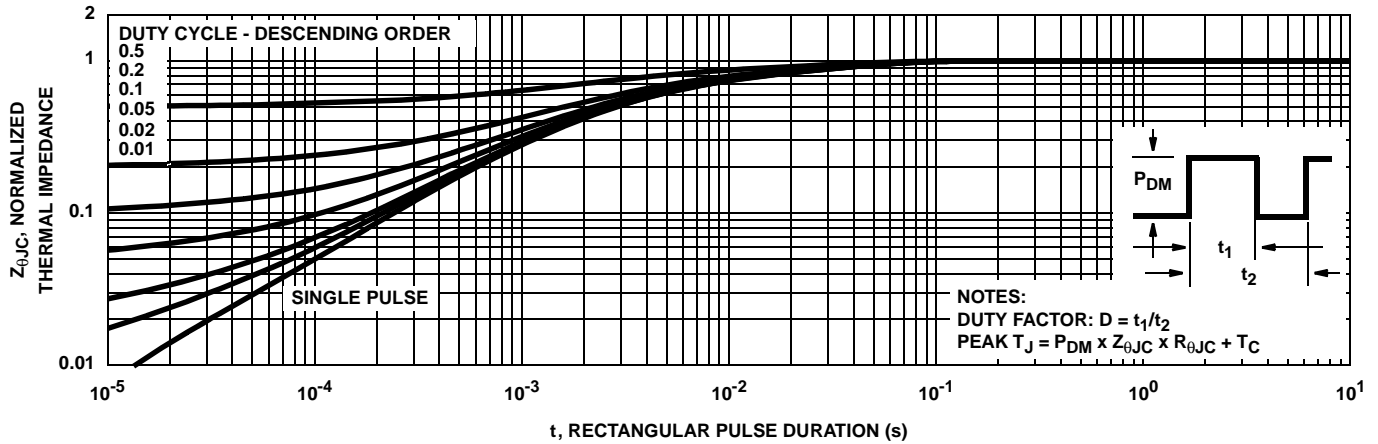

FIGURE 3. NORMALIZED MAXIMUM TRANSIENT THERMAL IMPEDANCE

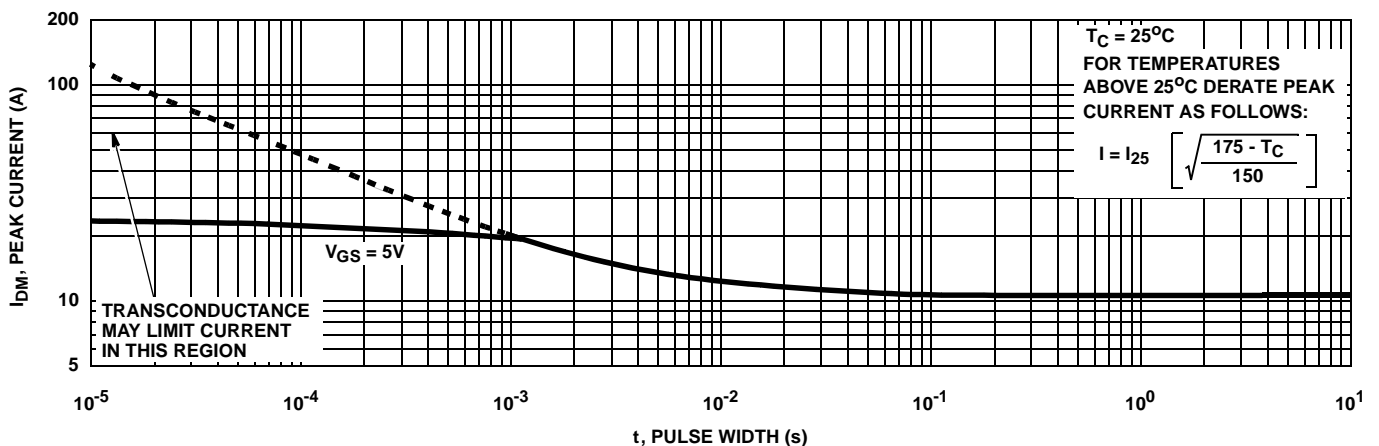

FIGURE 4. PEAK CURRENT CAPABILITY

Typical Performance Curves

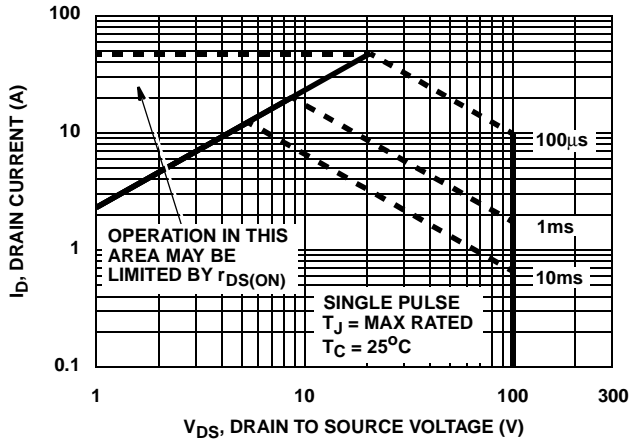

FIGURE 5. FORWARD BIAS SAFE OPERATING AREA

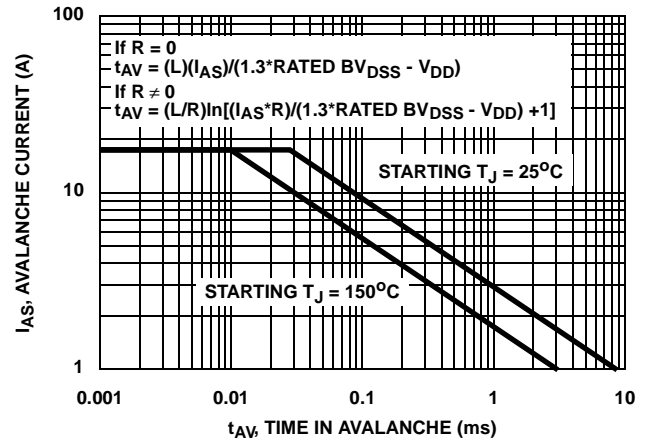

FIGURE 6. UNCLAMPED INDUCTIVE SWITCHING CAPABILITY

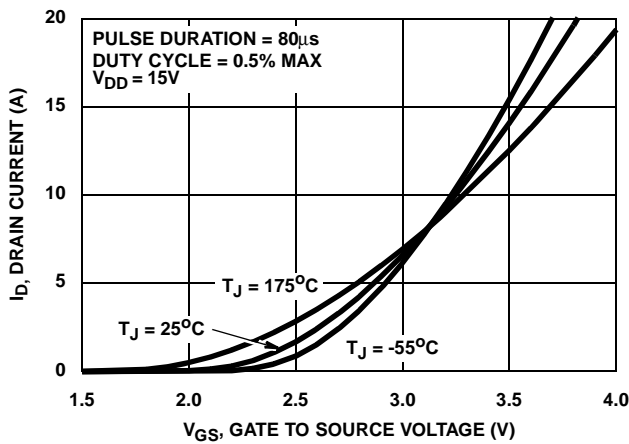

FIGURE 7. TRANSFER CHARACTERISTICS

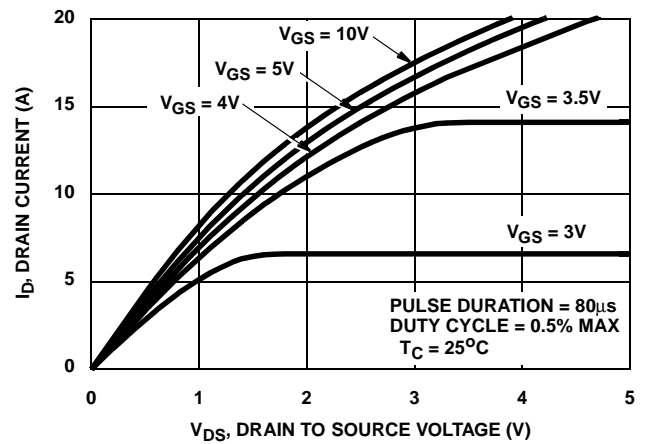

FIGURE 8. SATURATION CHARACTERISTICS

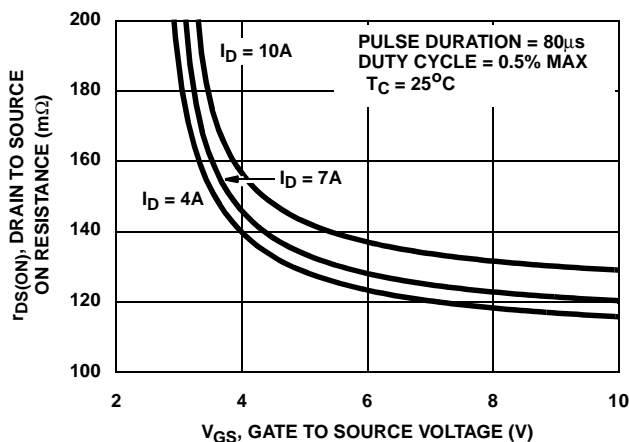

FIGURE 9. DRAIN TO SOURCE ON RESISTANCE vs GATE VOLTAGE AND DRAIN CURRENT

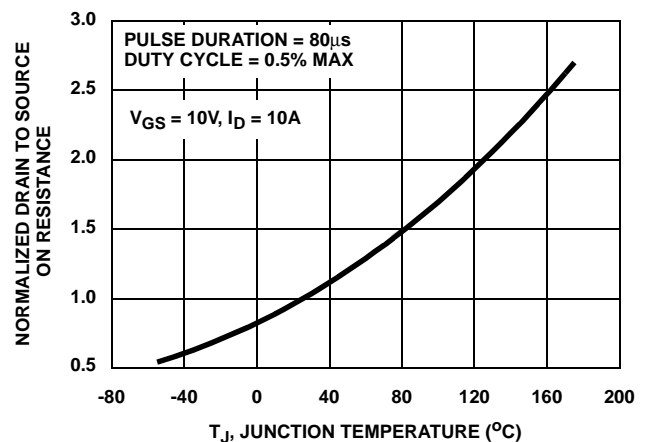

FIGURE 10. NORMALIZED DRAIN TO SOURCE ON RESISTANCE vs JUNCTION TEMPERATURE

Typical Performance Curves

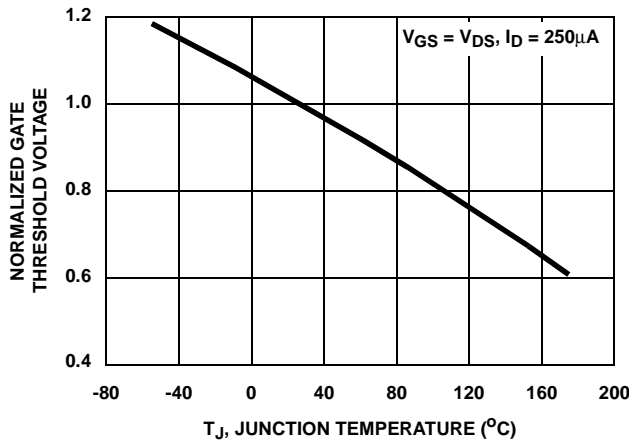

FIGURE 11. NORMALIZED GATE THRESHOLD VOLTAGE vs JUNCTION TEMPERATURE

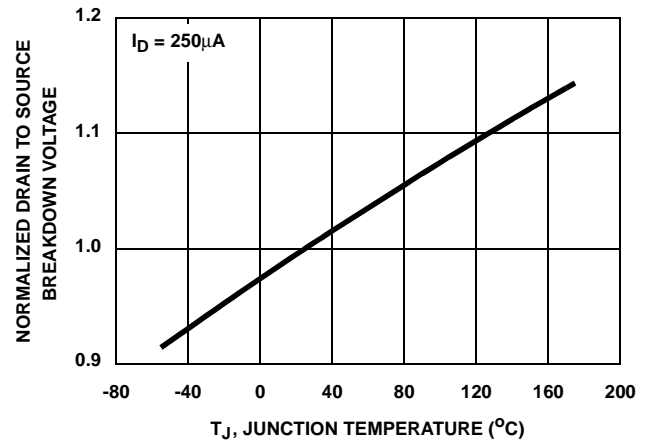

FIGURE 12. NORMALIZED DRAIN TO SOURCE BREAKDOWN VOLTAGE vs JUNCTION TEMPERATURE

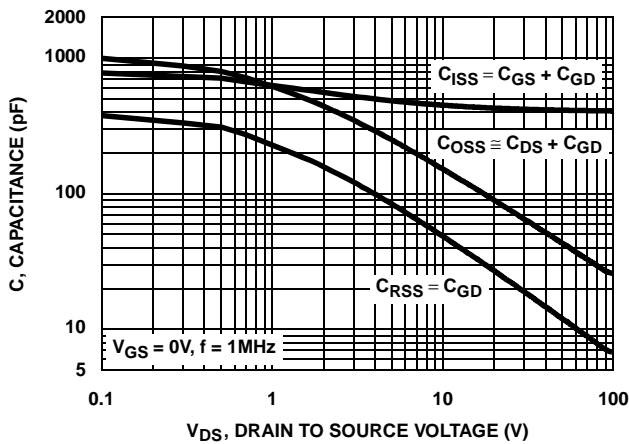

FIGURE 13. CAPACITANCE vs DRAIN TO SOURCE VOLTAGE

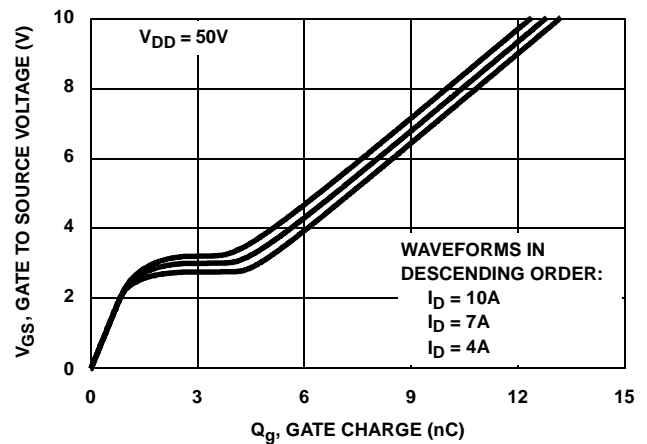

FIGURE 14. GATE CHARGE WAVEFORMS FOR CONSTANT GATE CURRENT

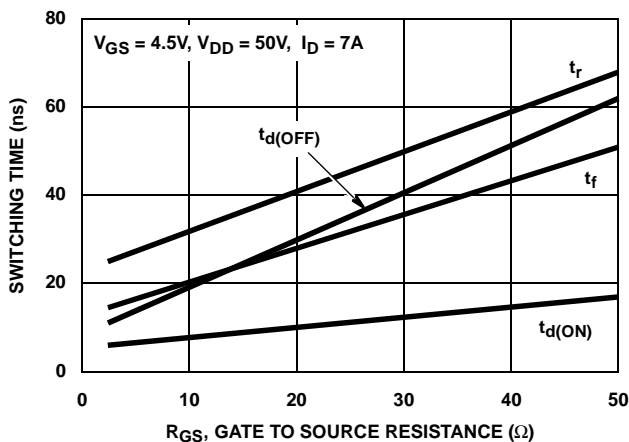

FIGURE 15. SWITCHING TIME vs GATE RESISTANCE

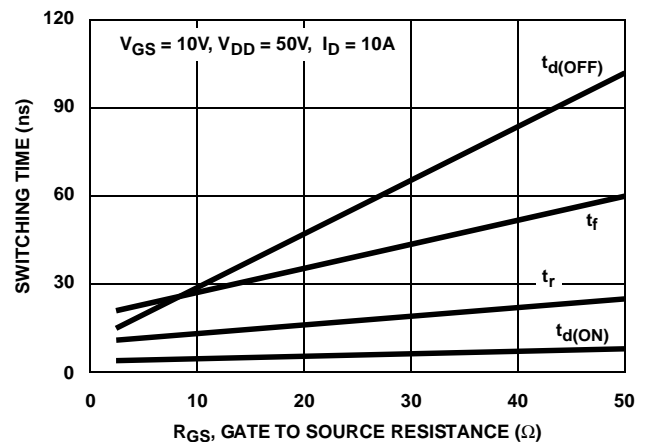
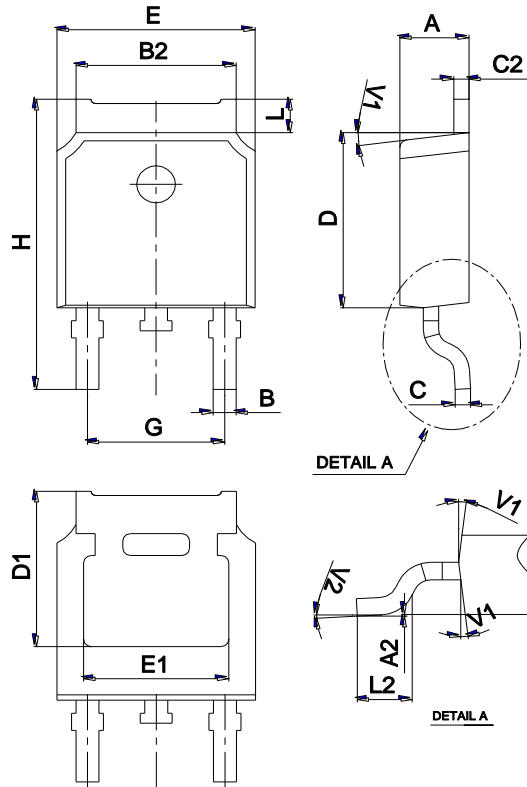

FIGURE 16. SWITCHING TIME vs GATE RESISTANCE

Package Mechanical Data TO-252



Ref.	Dimensions					
	Millimeters			Inches		
	Min.	Typ.	Max.	Min.	Typ.	Max.
A	2.10		2.50	0.083		0.098
A2	0		0.10	0		0.004
B	0.66		0.86	0.026		0.034
B2	5.18		5.48	0.202		0.216
C	0.40		0.60	0.016		0.024
C2	0.44		0.58	0.017		0.023
D	5.90		6.30	0.232		0.248
D1	5.30REF			0.209REF		
E	6.40		6.80	0.252		0.268
E1	4.63			0.182		
G	4.47		4.67	0.176		0.184
H	9.50		10.70	0.374		0.421
L	1.09		1.21	0.043		0.048
L2	1.35		1.65	0.053		0.065
V1		7°			7°	
V2	0°		6°	0°		6°

Marking

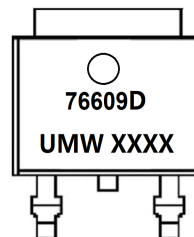

Ordering information

Order code	Package	Baseqty	Deliverymode
UMW HUF76609D3	TO-252	2500	Tape and reel