

SOT-223 Plastic-Encapsulate MOSFETS

CJT04N15 N-Channel Power MOSFET

$V_{(BR)DSS}$	$R_{DS(on)MAX}$	I_D
150V	160mΩ@10V	4A

SOT-223

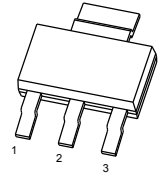

1. GATE
2. DRAIN
3. SOURCE

GENERAL DESCRIPTION

This CJT04N15 use advanced trench technology and design to provide excellent $R_{DS(ON)}$ with low gate charge. It can be used in a wide variety of applications.

FEATURE

- High density cell design for ultra low $R_{DS(ON)}$
- Fully characterized avalanche voltage and current
- Excellent package for good heat dissipation

MARKING

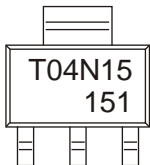

T04N15= Device code
151=Code

EQUIVALENT CIRCUIT

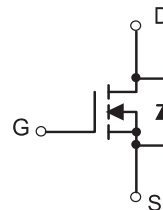

Maximum ratings ($T_a=25^{\circ}C$ unless otherwise noted)

Parameter	Symbol	Value	Unit
Drain-Source Voltage	V_{DS}	150	V
Gate-Source Voltage	V_{GS}	±20	
Continuous Drain Current	I_D	4	A
Pulsed Drain Current(note1)	I_{DM}	16	
Thermal Resistance from Junction to Ambient	$R_{\theta JA}$	125	$^{\circ}C/W$
Thermal Resistance from Junction to Case *	$R_{\theta JC}$	8.33	$^{\circ}C/W$
Junction Temperature	T_J	150	$^{\circ}C$
Storage Temperature Range	T_{STG}	-55 ~+150	
Maximum lead temperure for soldering purposes , 1/8"from case for 5 seconds	T_L	260	

* Device mounted on 1"×1" FR-4 PCB with high coverage 2oz Copper .

MOSFET ELECTRICAL CHARACTERISTICS

$T_a=25^\circ\text{C}$ unless otherwise specified

Parameter	Symbol	Test Condition	Min	Typ	Max	Unit
Off characteristics						
Drain-source breakdown voltage	$V_{(BR)DSS}$	$V_{GS} = 0V, I_D = 250\mu A$	150			V
Drain-source diode forward voltage(note2)	V_{SD}	$V_{GS} = 0V, I_S = 2.0A$			1.2	
Zero gate voltage drain current	I_{DSS}	$V_{DS} = 150V, V_{GS} = 0V$			1	μA
Gate-body leakage current (note2)	I_{GSS}	$V_{DS} = 0V, V_{GS} = \pm 20V$			± 100	nA
On characteristics (note2)						
Gate-threshold voltage	$V_{GS(th)}$	$V_{DS} = V_{GS}, I_D = 250\mu A$	1.5	2.0	2.5	V
Static drain-source on-resistance	$R_{DS(on)}$	$V_{GS} = 10V, I_D = 4.0A$		130	160	m Ω
Forward transconductance	g_{fs}	$V_{DS} = 15V, I_D = 4A$	5			S
Dynamic characteristics (note 3)						
Input capacitance	C_{iss}	$V_{DS} = 25V, V_{GS} = 0V, f = 1MHz$		900		pF
Output capacitance	C_{oss}			115		
Reverse transfer capacitance	C_{rss}			70		
Switching characteristics (note 3)						
Total gate charge	Q_g	$V_{DS} = 75V, V_{GS} = 10V, I_D = 1.5A$		19		nC
Gate-source charge	Q_{gs}			5.5		
Gate-drain charge	Q_{gd}			7		
Turn-on delay time (note3)	$t_{d(on)}$	$V_{DS} = 75V, V_{GS} = 10V, R_G = 6\Omega, I_D = 1.0A, R_L = 75\Omega$		8		ns
Turn-on rise time (note3)	t_r			10		
Turn-off delay time (note3)	$t_{d(off)}$			20		
Turn-off fall time (note3)	t_f			15		

Notes :

1. Repetitive Rating:Pulse width limited by maximum junction temperature.
2. Pulse Test : Pulse width $\leq 300\mu s$, duty cycle $\leq 2\%$.
3. These parameters have no way to verify.

Typical Characteristics

Output Characteristics

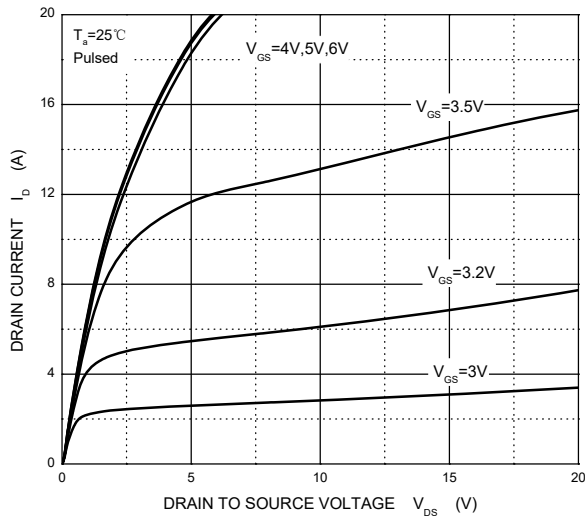

Transfer Characteristics

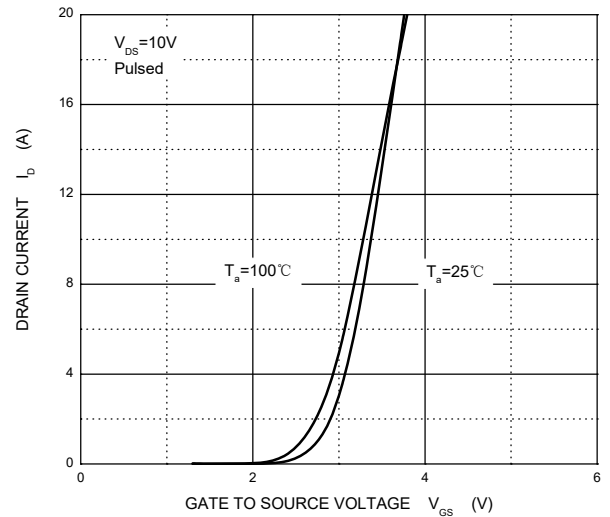

$R_{DS(ON)}$ — I_D

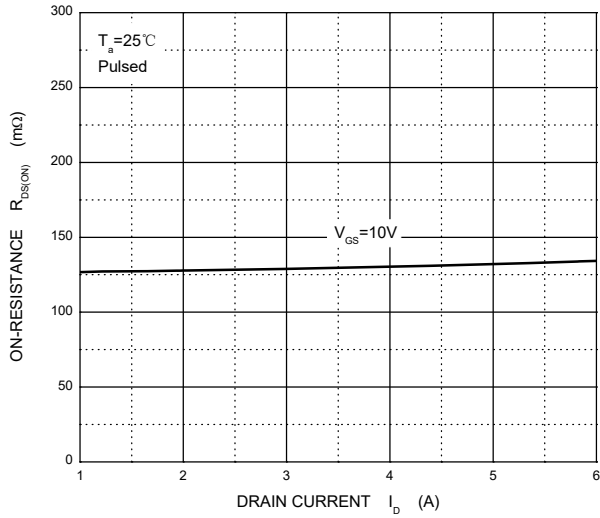

$R_{DS(ON)}$ — V_{GS}

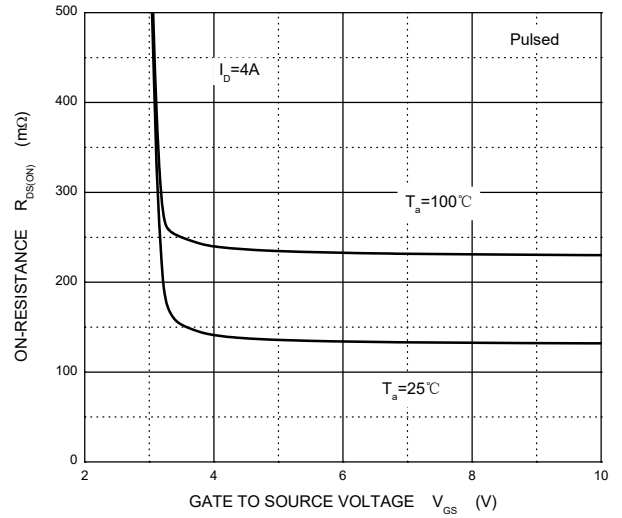

I_S — V_{SD}

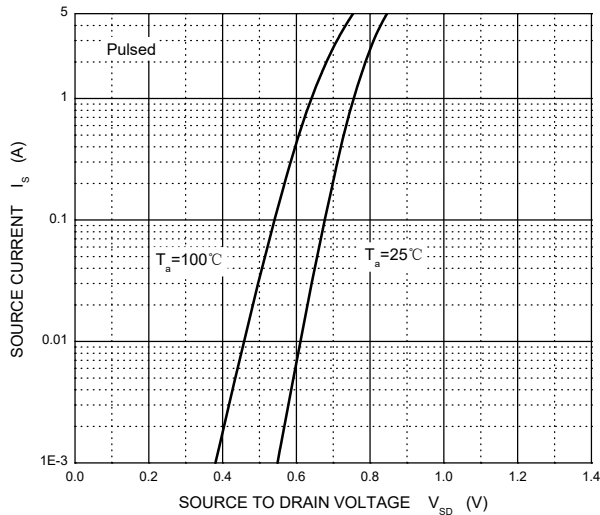

Threshold Voltage

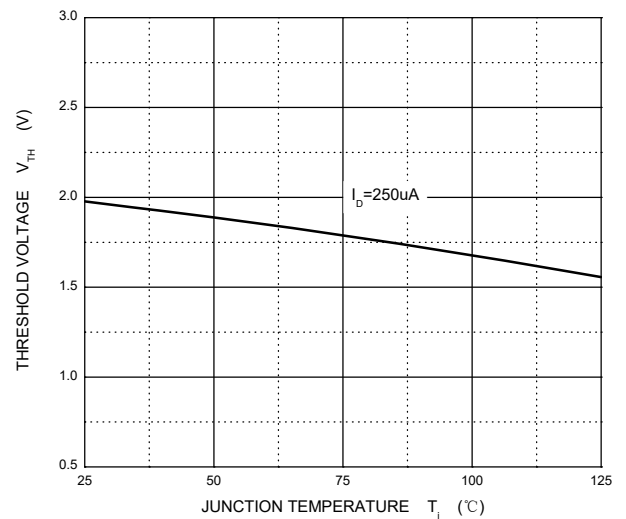

SOT-223 Package Outline Dimensions

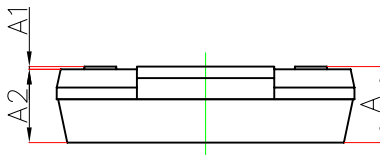
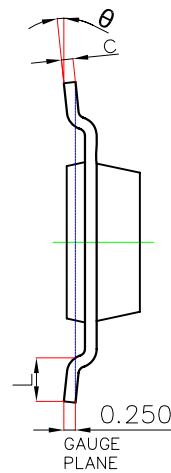
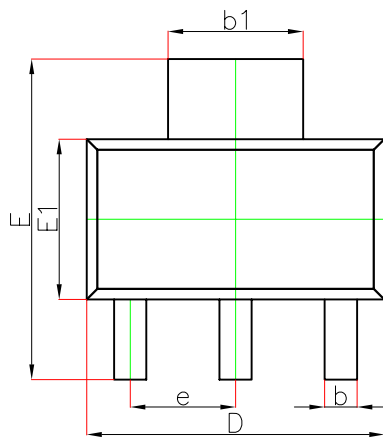

Symbol	Dimensions In Millimeters		Dimensions In Inches	
	Min.	Max.	Min.	Max.
A	—	1.800	—	0.071
A1	0.020	0.100	0.001	0.004
A2	1.500	1.700	0.059	0.067
b	0.660	0.840	0.026	0.033
b_1	2.900	3.100	0.114	0.122
c	0.230	0.350	0.009	0.014
D	6.300	6.700	0.248	0.264
E	6.700	7.300	0.264	0.287
E1	3.300	3.700	0.130	0.146
e	2.300(BSC)		0.091(BSC)	
L	0.750	—	0.030	—
θ	0°	10°	0°	10°

SOT-223 Suggested Pad Layout

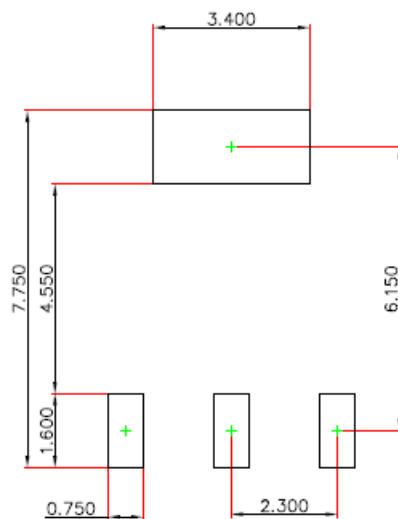

Note:

1. Controlling dimension: in millimeters.
2. General tolerance: ± 0.050 mm.
3. The pad layout is for reference purposes only.

NOTICE

JSCJ reserves the right to make modifications, enhancements, improvements, corrections or other changes without further notice to any product herein. JSCJ does not assume any liability arising out of the application or use of any product described herein.

SOT-223 Tape and Reel

SOT-223 Embossed Carrier Tape

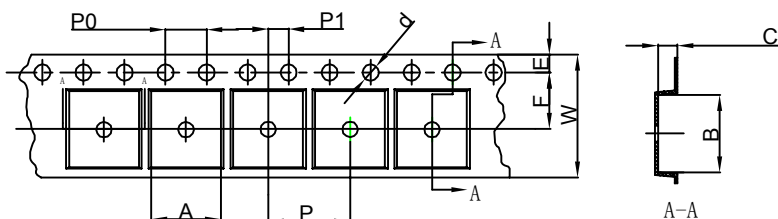

Packaging Description:

SOT-223 parts are shipped in tape. The carrier tape is made from a dissipative (carbon filled) polycarbonate resin. The cover tape is a multilayer film (Heat Activated Adhesive in nature) primarily composed of polyester film, adhesive layer, sealant, and anti-static sprayed agent. These reeled parts in standard option are shipped with 2,500 units per 13" or 33.0cm diameter reel. The reels are clear in color and is made of polystyrene plastic (anti-static coated).

Dimensions are in millimeter										
Pkg type	A	B	C	d	E	F	P0	P	P1	W
SOT-223	6.765	7.335	1.88	Ø1.50	1.75	5.50	4.00	8.00	2.00	12.00

SOT-223 Tape Leader and Trailer

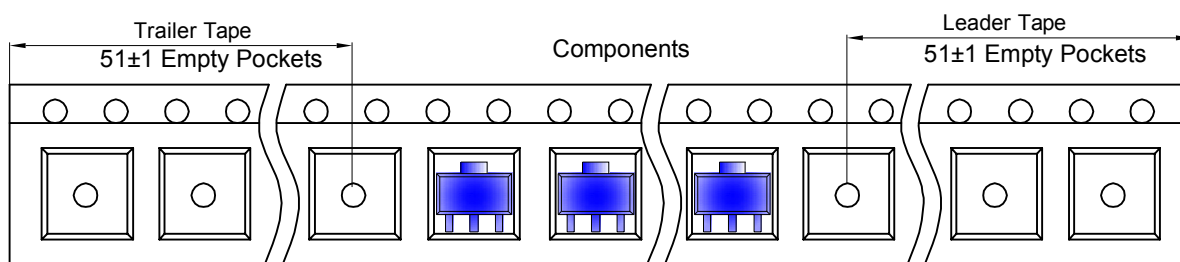

SOT-223 Reel

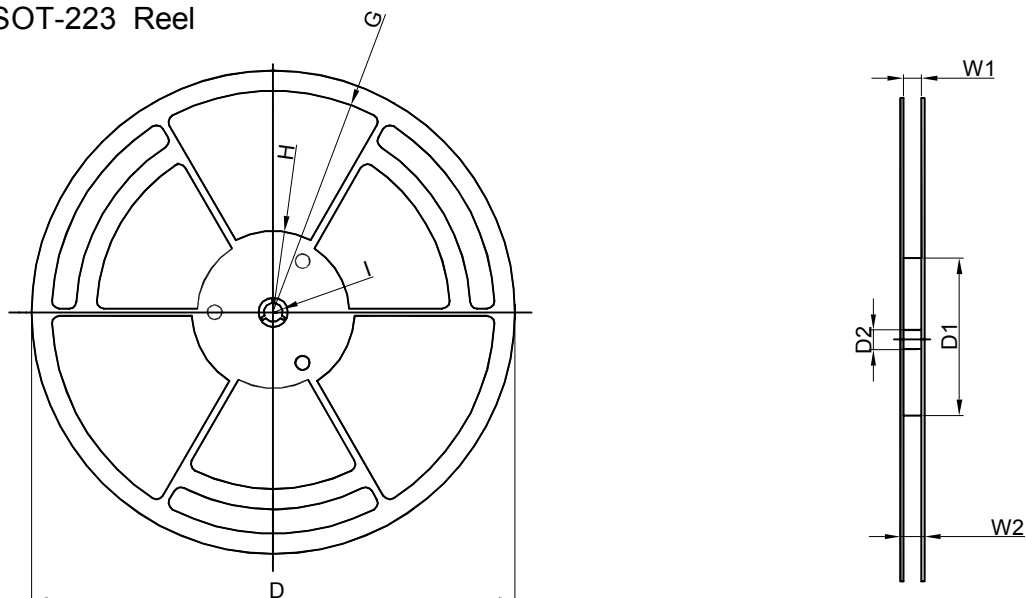

Dimensions are in millimeter								
Reel Option	D	D1	D2	G	H	I	W1	W2
13" Dia	Ø330.00	100.00	13.00	R151.00	R56.00	R6.50	12.40	17.60

REEL	Reel Size	Box	Box Size(mm)	Carton	Carton Size(mm)	G.W.(kg)
2,500 pcs	13 inch	2,500 pcs	336×336×48	20,000 pcs	445×355×365	