

## Medium Sensitivity Micropower Omnipolar Hall-effect Switch

### Features

- Medium sensitivity omnipolar operation
- Micropower operation:  
Typ 0.8 $\mu$ A (average:VDD=1.8V)
- On board voltage regulator for 1.6V to 5.5V range  
Magnetic threshold options (Sensitivity Bop, Brp) :  
- Bop= $\pm$ 32Gs, Brp= $\pm$ 27Gs
- Industry-leading ultra-low power consumption
- AW86512EDNTOB: 20Hz sampling rate options
- Wide operating temperature range: -40°C to 85°C
- Open-drain output
- WBTO92S-3L package

### Applications

- Smartphone.
- Notebook computer.
- Handheld gaming consoles.
- Bluetooth headset.
- DV.
- Contact-less switch, Level, proximity and position switches in consumer products.

### General Description

The AW86512EDNTOB device is an ultra-low-power switch Hall effect sensor with Open-drain output, designed for the most compact and battery-sensitive systems. The supply range of AW86512EDNTOB is 1.6V to 5.5V to support portable equipment.

When the magnetic field strength is greater than Bop, then the device output is pulled low; When the magnetic field strength is less than Brp, then the device output is pulled high; When the magnetic field strength is between Bop and Brp, then the device output remains in the previous state.

### Typical Application Circuit

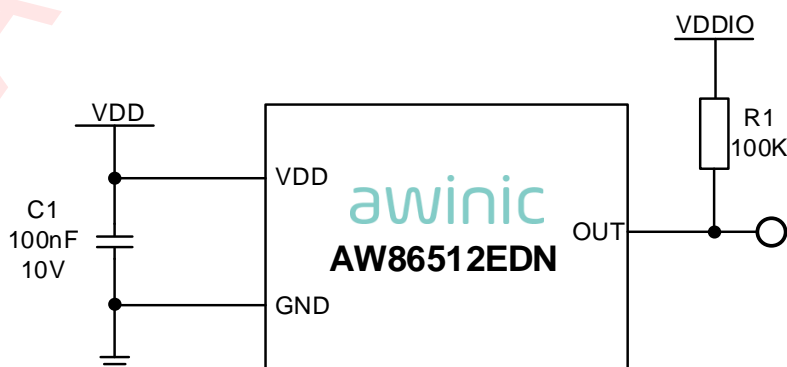
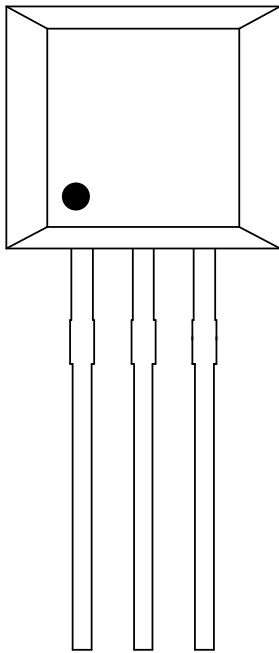

Figure 1 Typical Application Circuit of AW86512EDNTOB

## Pin Configuration And Top Mark

AW86512EDNTOB  
Top View



AW86512EDNTOB Marking  
Top View

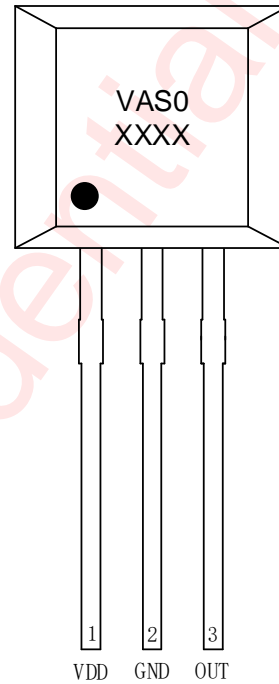

VAS0 - AW86512EDNTOB  
XXXX - Production Tracing Code

Figure 2 Pin Configuration And Top Mark

## Pin Definition

No.	NAME	DESCRIPTION
1	VDD	Power Supply
2	GND	Ground
3	OUT	Omnipolar open-drain output that responds to north and south magnetic The open drain output requires a resistor pullup

## Functional Block Diagram

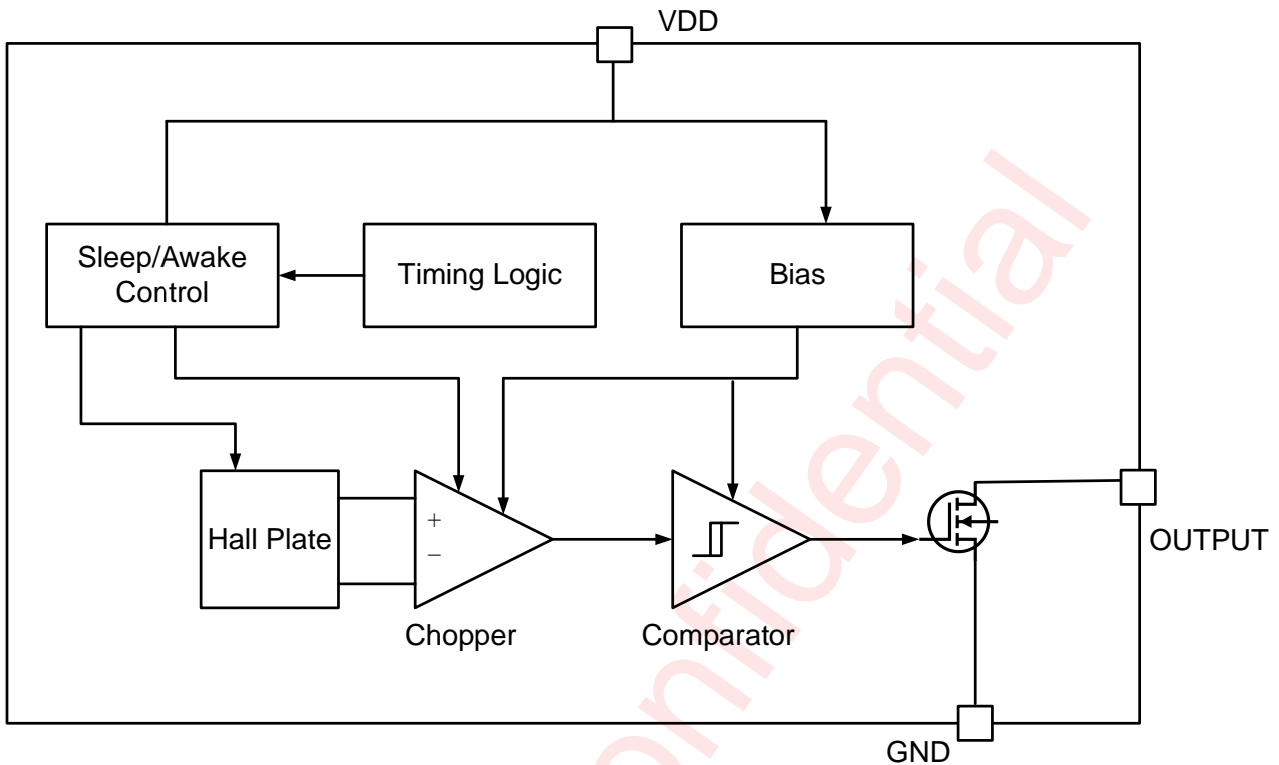

Figure 3 Functional Block Diagram of AW86512EDNTOB

## Ordering Information

Part Number	Temperature	Package	Marking	Moisture Sensitivity Level	Environmental Information	Delivery Form
AW86512EDNTOB	-40°C~85°C	WBTO92S-3L	VAS0	NA	ROHS+HF	10000 units

## Detailed Functional Description

When the magnetic field strength is greater than  $B_{op}$ , then the device output is pulled low; When the magnetic field strength is less than  $B_{rp}$ , then the device output is pulled high; When the magnetic field strength is between  $B_{op}$  and  $B_{rp}$ , then the device output remains in the previous state.

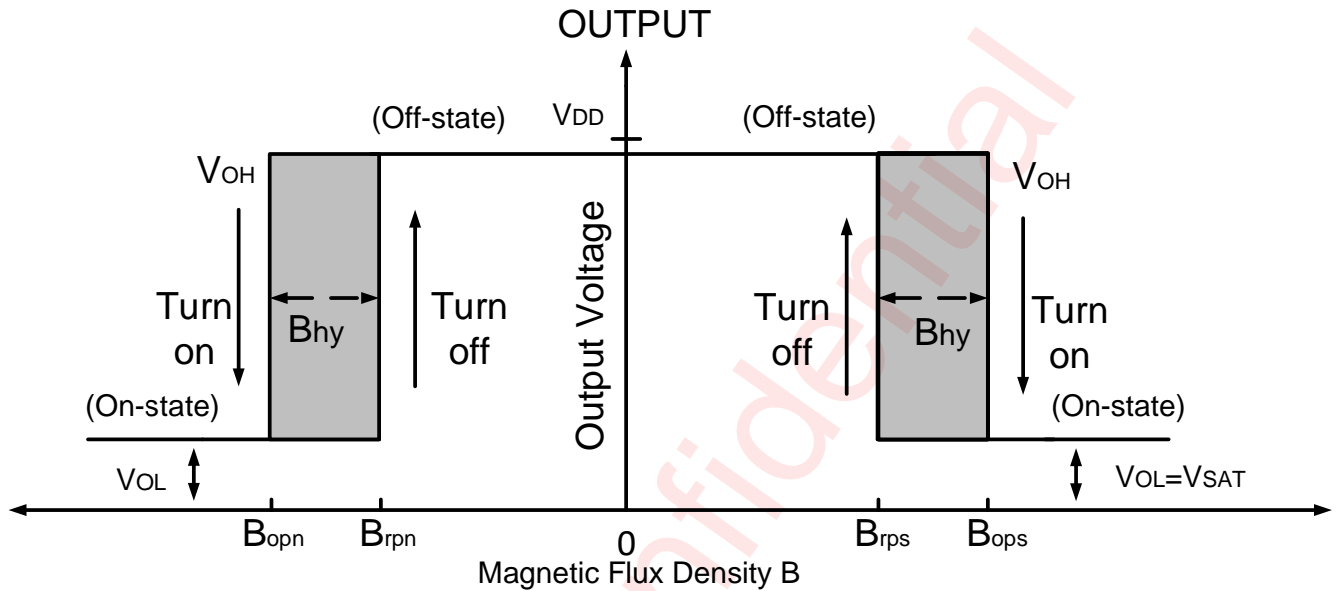

Figure 4 The Working Process of Omnipolar output

## Absolute Maximum Ratings

PARAMETERS	RANGE
Supply Voltage	-0.3V to 6V
Supply Current	4mA
Output Voltage	-0.4V to $V_{DD}+0.4V$
Output Current	4mA
Operating Ambient Temperature $T_A$	-40°C to 85°C
Storage Temperature $T_{STG}$	-65°C to 150°C
Junction temperature $T_J$	-50°C to 165°C
Magnetic Flux	No limit
Package Power Dissipation	230mW
Lead temperature (soldering 10 seconds)	260°C
ESD Rating <sup>(NOTE 2 3)</sup>	
HBM(Human Body Model)	±6kV
CDM(Charge Device Model)	±1.5kV
Latch-up	
Test Condition: JESD78E	+IT: 200mA -IT: 200mA

**NOTE1:** Conditions out of those ranges listed in "absolute maximum ratings" may cause permanent damages to the device. In spite of the limits above, functional operation conditions of the device should within the ranges listed in "recommended operating conditions". Exposure to absolute-maximum-rated conditions for prolonged periods may affect device reliability.

**NOTE2:** The human body model is a 100pF capacitor discharged through a 1.5kΩ resistor into each pin. Test method: ESDA/JEDEC JS -001-2017.

**NOTE3:** Charge Device Model test method: ESDA/JEDEC JS-002-2018.

## Electrical Characteristics

VDD=3.3V supply, T<sub>A</sub>= 25°C (unless otherwise noted)

Symbol	Characteristic	Test Conditions	Min	Typ	Max	Unit
V <sub>DD</sub>	Supply Voltage	Operating, T <sub>J</sub> < 165°C	1.6		5.5	V
I <sub>DD(awake)</sub> (Note1)	Supply Current	During awake period, T <sub>A</sub> = 25°C, VDD=3.3V	-	0.95	1.3	mA
I <sub>DD(sleep)</sub>		During sleep period, T <sub>A</sub> = 25°C, VDD = 3.3V	-	0.43	0.8	μA
I <sub>DD(avg)</sub> (Note1)	Average supply current	T <sub>A</sub> = 25°C, VDD = 1.8V, f <sub>s</sub> =20Hz	-	0.8	-	μA
		T <sub>A</sub> = 25°C, VDD = 3.3V, f <sub>s</sub> =20Hz	-		1.7	μA
V <sub>OL</sub>	Output low voltage(on)	I <sub>OUT</sub> = 1 mA	-	0.1	0.2	V
T <sub>awake</sub> (Note1)	Awake time	(note)	-	40	60	μs
T <sub>period</sub>	Period	f <sub>s</sub> =20Hz(sampling rate)		50	75	ms
D.C.	Duty cycle	-	-	0.08	-	%
f <sub>c</sub>	Chopping Frequency		-	500	-	kHz
I <sub>OFF</sub> (Note1)	Output Leakage Current	V <sub>OUT</sub> = 5.5 V; Switch state=off	-	-	0.1	μA

Note: Maximum and minimum parameters values over operating temperature range are not tested in production. They are guaranteed by design, characterization and process control. The magnetic field strength (Gauss) required to cause the switch to change state (operate and release) will be as specified in the magnetic characteristics. To test the switch against the specified magnetic characteristics, the switch must be placed in a uniform magnetic field.

Note1: Minimum and/or maximum limit is guaranteed by design and by statistical analysis of device characterization data. The specification is not guaranteed by production testing.

## Magnetic Characteristics

V<sub>DD</sub>=3.3V supply, T<sub>A</sub>=+25°C for typical values (unless otherwise noted)

(1 mT=10 Gauss)

Symbol	Characteristics	Test condition	Min	Typ	Max	Unit
Bops(south pole to part marking side)	Operation Point		23	32	41	Gauss
		V <sub>DD</sub> =1.6V to 5.5V, T <sub>A</sub> =-40°C to +85°C	20	32	44	
Bopn (north pole to part marking side)	Operation Point		-41	-32	-23	
		V <sub>DD</sub> =1.6V to 5.5V, T <sub>A</sub> =-40°C to +85°C	-44	-32	-20	
Brps(south pole to part marking side)	Release Point		18	27	36	
		V <sub>DD</sub> =1.6V to 5.5V, T <sub>A</sub> =-40°C to +85°C	15	27	39	
Brpn (north pole to part marking side)	Release Point		-36	-27	-18	
		V <sub>DD</sub> =1.6V to 5.5V, T <sub>A</sub> =-40°C to +85°C	-39	-27	-15	
Bhy ( Bopx - Brpx )	Hysteresis		-	5	-	

Notes: Typical data is at T<sub>A</sub>=+25°C, V<sub>DD</sub>=3.3V.

Maximum and minimum parameters values over operating temperature range are not tested in production. They are guaranteed by design, characterization and process control. The magnetic characteristics may vary with supply voltage, operating temperature and after soldering.

## Typical Characteristics

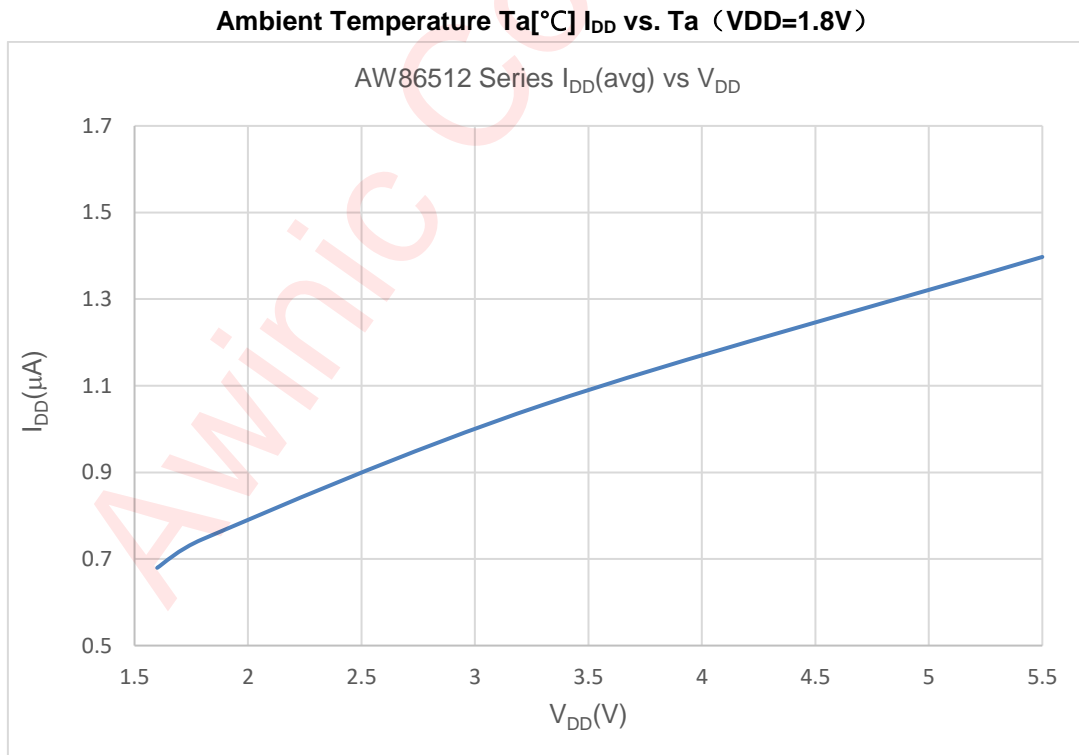
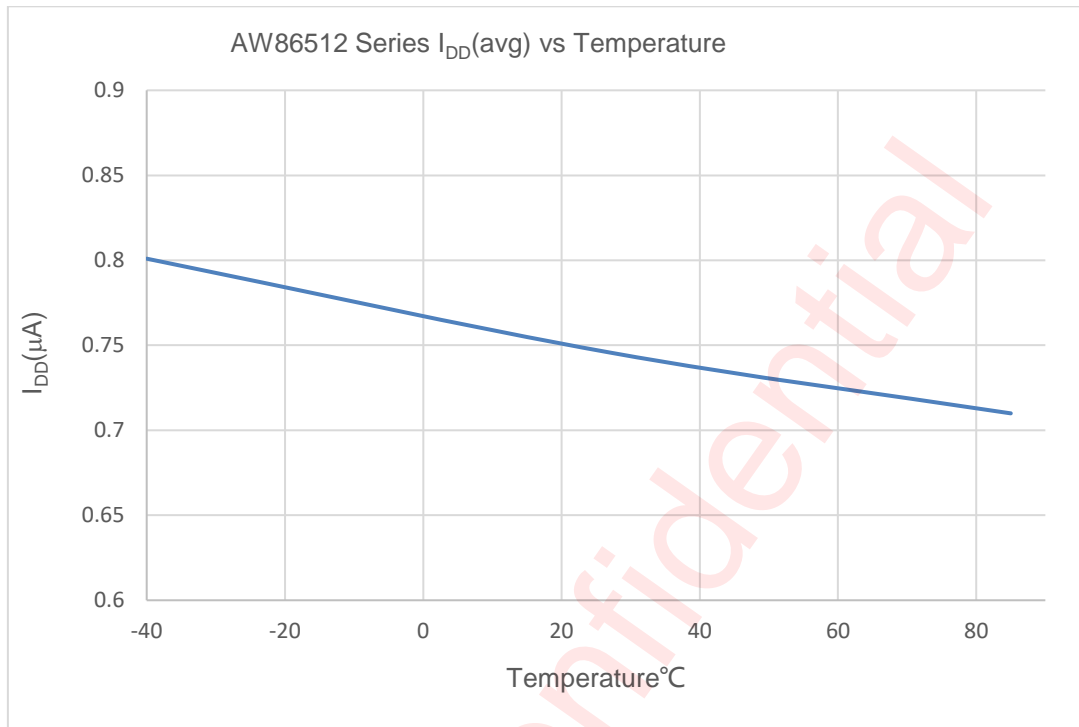

Average Supply Current vs. Supply Voltage ( $T_a=25^\circ\text{C}$ )

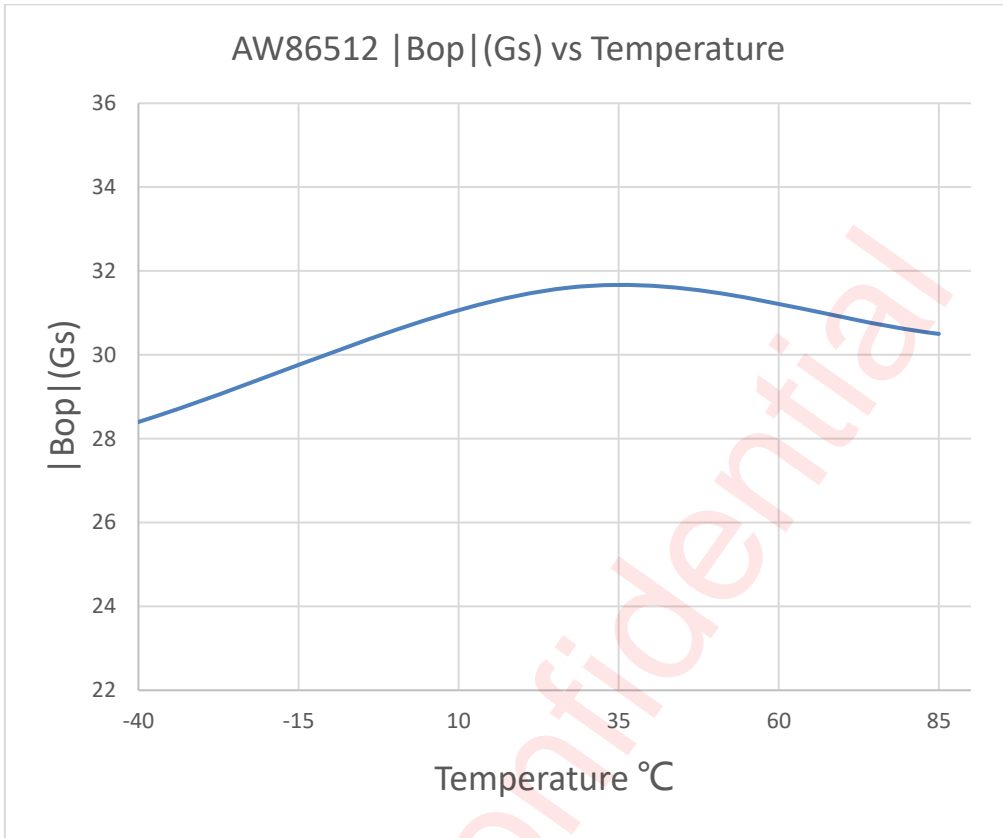

Ambient Temperature Ta[°C] |Bop| vs. Ta(V<sub>DD</sub>=3.3V)

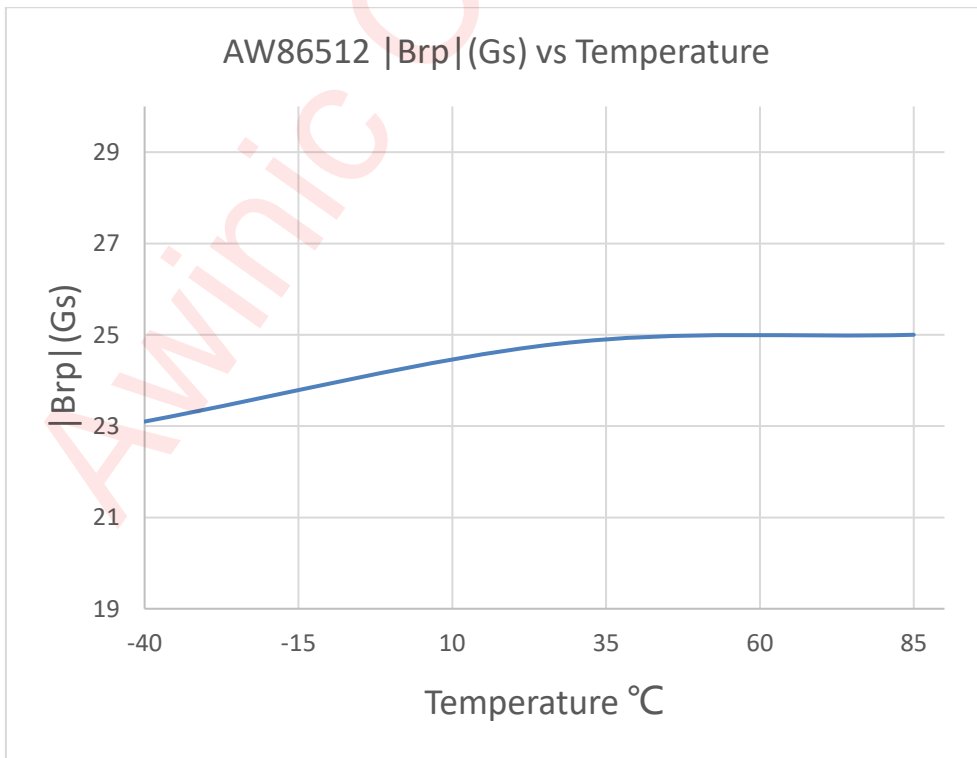

Ambient Temperature Ta[°C] |Brp| vs. Ta(V<sub>DD</sub>=3.3V)

## Application Information

1. It is recommended to connect an external capacitor of 100nF to VDD and GND. The noise of the injection device can be reduced.
2. The out pin of the chip is an open-drain output, and a pull-up resistor is required. A 100K resistor is recommended. The pull-up power supply depends on the IO power supply of the master controller. It can be powered separately. If the voltage of the master control power supply is the same as that of the chip power supply, the OUT can also be pulled up to the VDD power supply of the Hall chip.

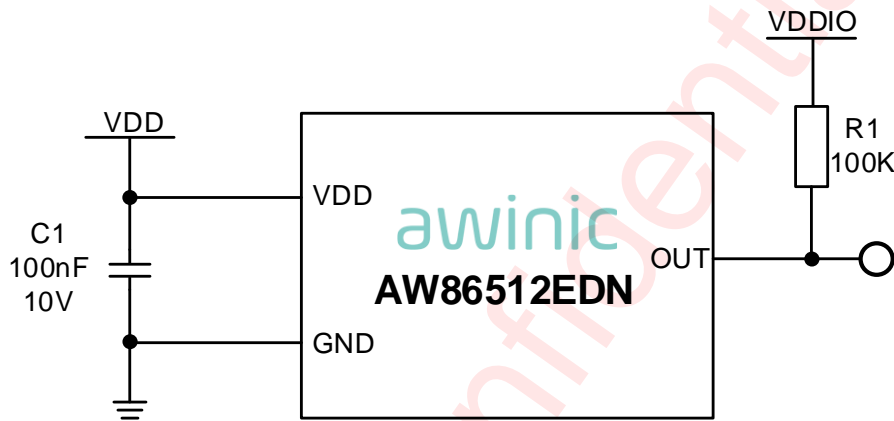
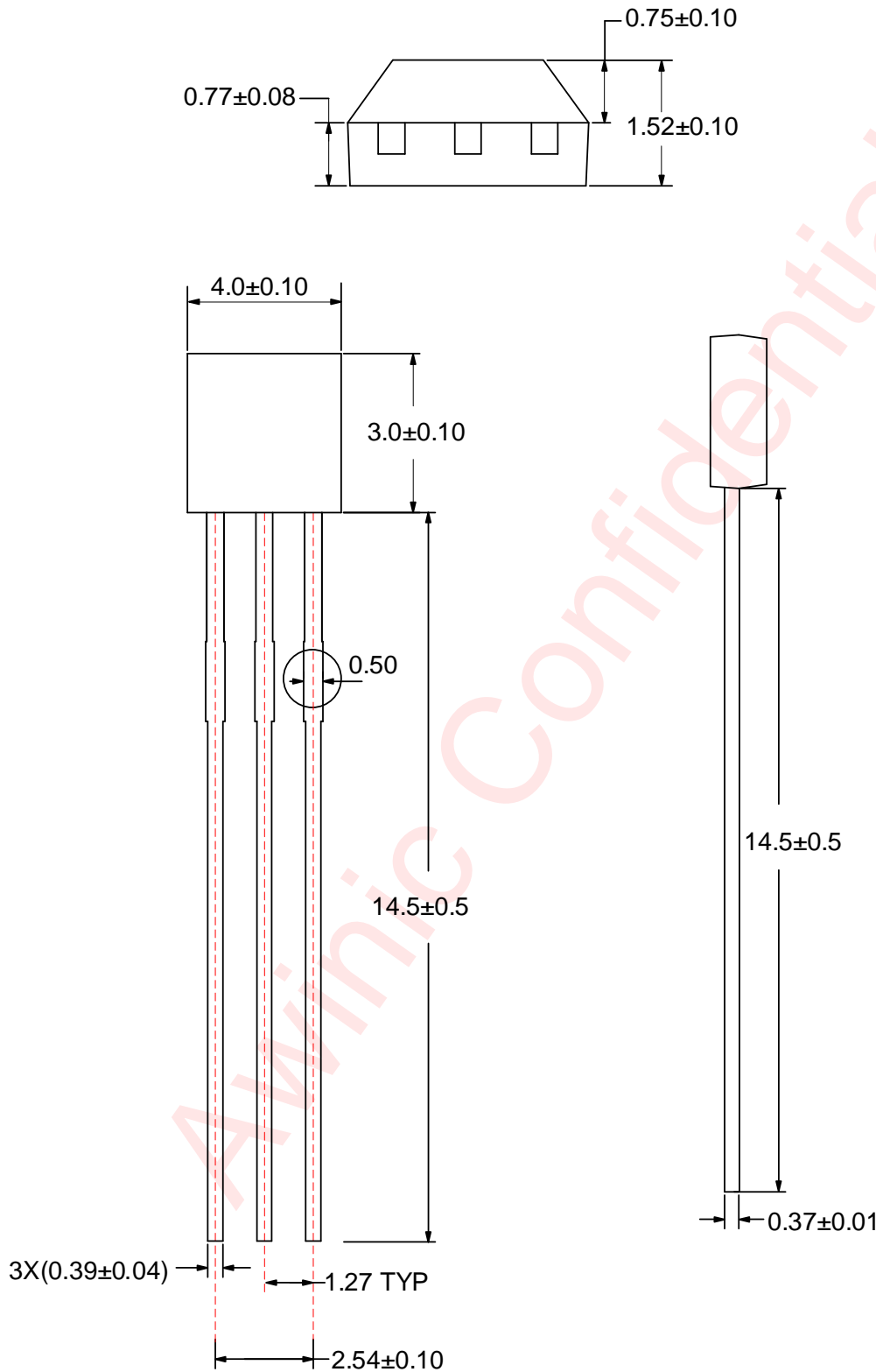

Figure 5 The Application Circuit of AW86512EDNTOB

Package Description



## Revision History

Version	Date	Change Record
V1.0	Dec. 2024	Officially released
V1.1	Apr. 2025	Change the Delivery Form to 10000 Uints

Awinic Confidential

## Disclaimer

All trademarks are the property of their respective owners. Information in this document is believed to be accurate and reliable. However, Shanghai AWINIC Technology Co., Ltd (AWINIC Technology) does not give any representations or warranties, expressed or implied, as to the accuracy or completeness of such information and shall have no liability for the consequences of use of such information.

AWINIC Technology reserves the right to make changes to information published in this document, including without limitation specifications and product descriptions, at any time and without notice. Customers shall obtain the latest relevant information before placing orders and shall verify that such information is current and complete. This document supersedes and replaces all information supplied prior to the publication hereof.

AWINIC Technology products are not designed, authorized or warranted to be suitable for use in medical, military, aircraft, space or life support equipment, nor in applications where failure or malfunction of an AWINIC Technology product can reasonably be expected to result in personal injury, death or severe property or environmental damage. AWINIC Technology accepts no liability for inclusion and/or use of AWINIC Technology products in such equipment or applications and therefore such inclusion and/or use is at the customer's own risk.

Applications that are described herein for any of these products are for illustrative purposes only. AWINIC Technology makes no representation or warranty that such applications will be suitable for the specified use without further testing or modification.

All products are sold subject to the general terms and conditions of commercial sale supplied at the time of order acknowledgement.

Nothing in this document may be interpreted or construed as an offer to sell products that is open for acceptance or the grant, conveyance or implication of any license under any copyrights, patents or other industrial or intellectual property rights.

Reproduction of AWINIC information in AWINIC data books or data sheets is permissible only if reproduction is without alteration and is accompanied by all associated warranties, conditions, limitations, and notices. AWINIC is not responsible or liable for such altered documentation. Information of third parties may be subject to additional restrictions.

Resale of AWINIC components or services with statements different from or beyond the parameters stated by AWINIC for that component or service voids all express and any implied warranties for the associated AWINIC component or service and is an unfair and deceptive business practice. AWINIC is not responsible or liable for any such statements.