

AR0144_CSP_Demo3Head

Page	Description
1	Title Page
2	Block Diagram
3	Pinout
4	Sensor
5	Power
6	Clock and Reset
7	External Interfaces

Rev	Who	Date	Description
Rev 0.0	Joe KK	05/07/12	Initial
Rev 0.1	skumar	10/26/15	Initial
Rev 0.2	skumar	11/04/15 11/09/15	- Replaced C&K switch (PTS635SL25SMTRLFS) with TE switch part 147873-2 - Swapped parallel data signal at RP1,RP2,RP3 and RP4



ON Semiconductor®

Title Page		
Document Name	AR0144-CSP_Demo3Head	Rev 0.2
Date:	Monday, November 09, 2015	Sheet 1 of 7

Block Diagram

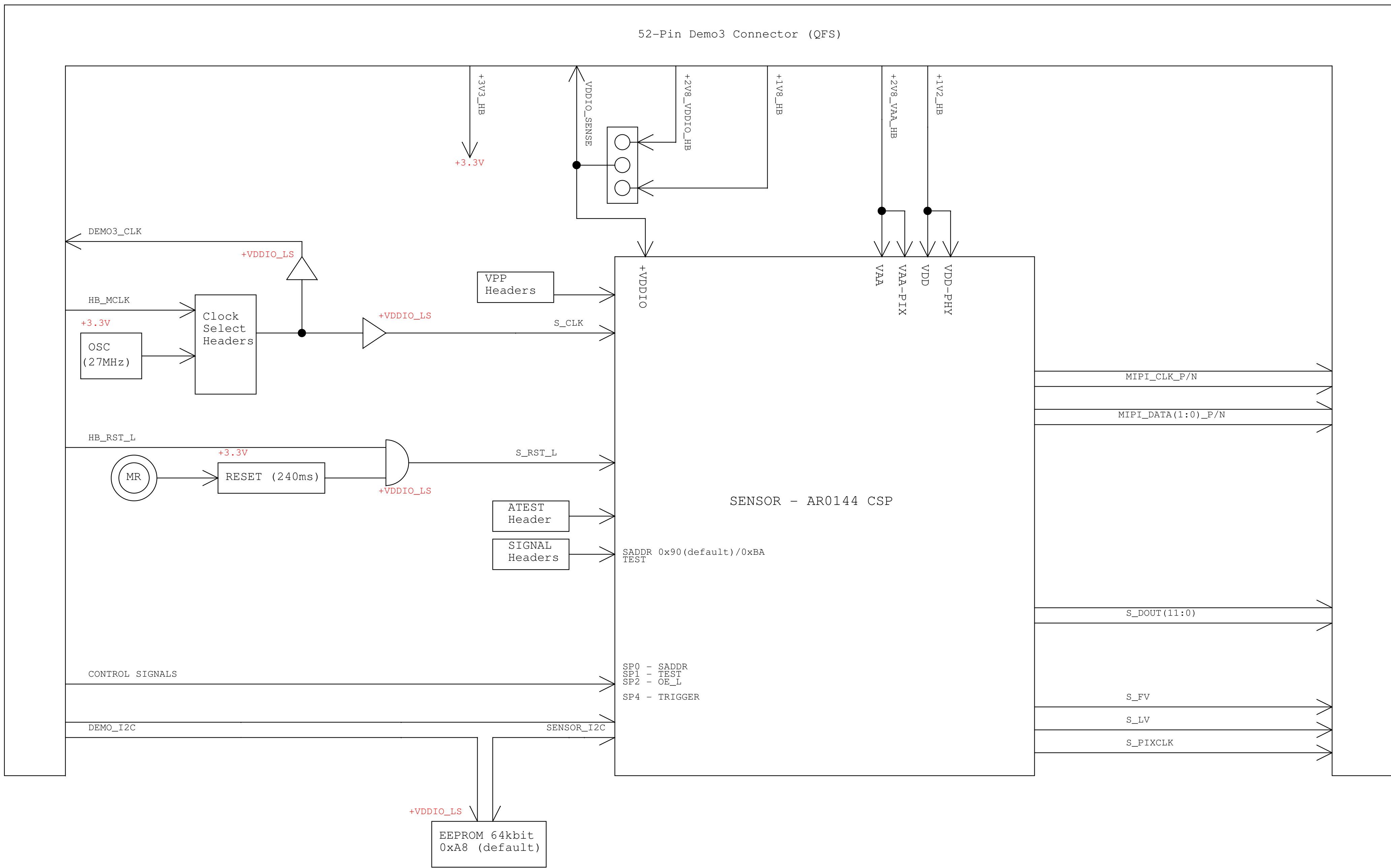

ON Semiconductor®

Title		
Block Diagram		
Size	Document Name	Rev
C	AR0144-CSP_Demo3Head	0.2
Date:		Sheet
Tuesday, November 03, 2015		2 of 7

Pinout

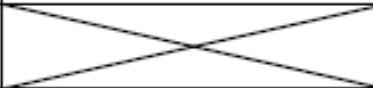
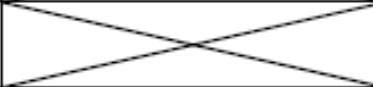
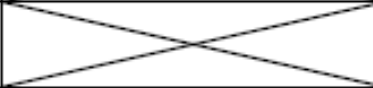
	1	2	3	4	5	6	7	8	9
A	DGND	VDDIO2V8R1V8	DVDD1V2	DATA1_P	CLK_P	DATA0_P	SHUTTER	TEST	
B	LINE_VALID	DVDD1V2	EXTCLK	DATA1_N	CLK_N	DATA0_N	SADDR	VDDIO2V8R1V8	
C	DOUT11	VDDIO2V8R1V8	PIXCLK	FRAME_VALID	DVDD1V2PHY	DVDD1V2	SCL	VDDIO2V8R1V8	
D	DOUT7	DOUT8	DOUT9	DOUT10	DGND	DGND	OUTPUT_ENABLE_N	DVDD1V2	AGND
E	DOUT5	DOUT6	VDDIO2V8R1V8	DOUT4	DOUT3	SDA	TRIGGER	DGND	VAAHV_NPIX
F	DGND	DVDD1V2	DOUT2	DOUT1	DOUT0	FLASH	DGND	DGND	VAAPIX_2V8
G	RESET_N	VAA2V8	AGND	DVDD1V2	DVDD1V2	DVDD1V2	AGND	VAA2V8	ATEST
H	VAA2V8	VAA2V8	AGND	DGND	DGND	DGND	AGND	VAA2V8	VAA2V8

TOP SIDE VIEW



ON Semiconductor®

Title		Pinout	
Size	Document Name	Rev	
C	AR0144-CSP_Demo3Head	0.2	
Date:	Tuesday, November 03, 2015	Sheet	3 of 7

Sensor

5	+5V0		+5V0	5
5	+3V3		+3V3	5,6
5	+VDDIO_LS		+VDDIO_LS	5,6,7
5	VDD		VDD	
5	VDD-PHY		VDD-PHY	
5	VDD-IO		VDD-IO	
5	VAA		VAA	
5	VAA-PIX		VAA-PIX	

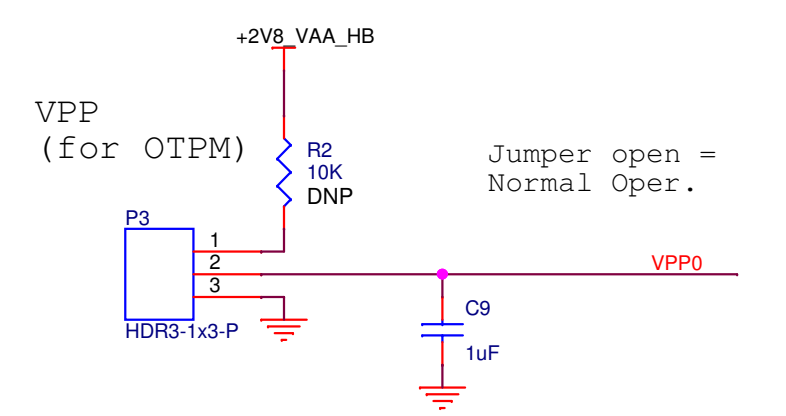
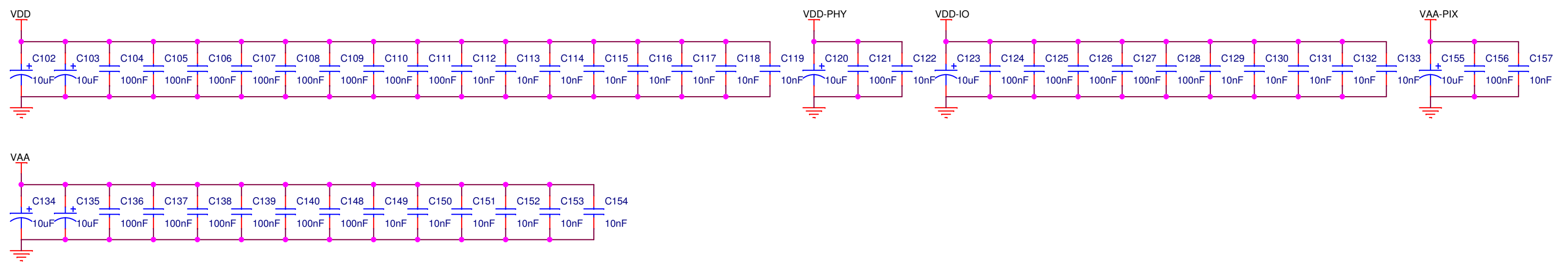

Layout Note

Place C101 near BGA Pin ATEST1

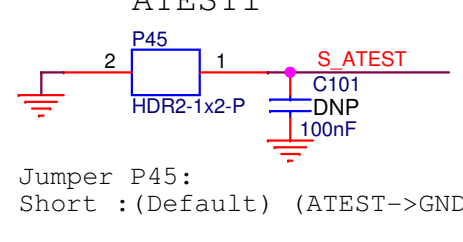

TRIGGER

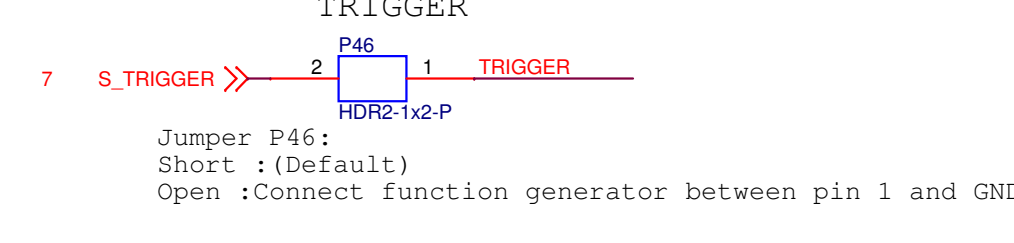

SADDR

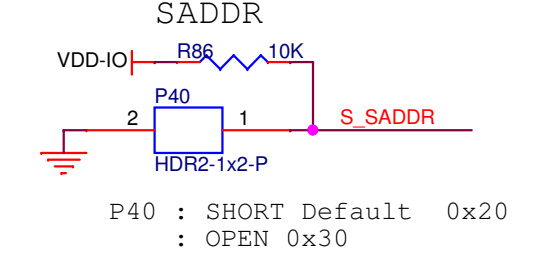

FLASH

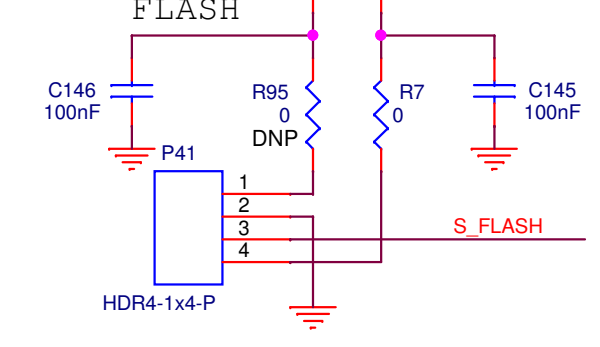

TEST

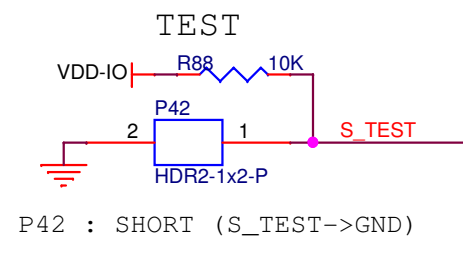

OE_L

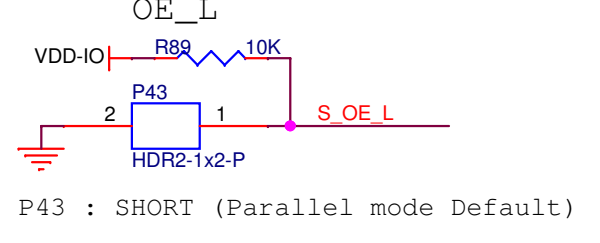

SHUTTER

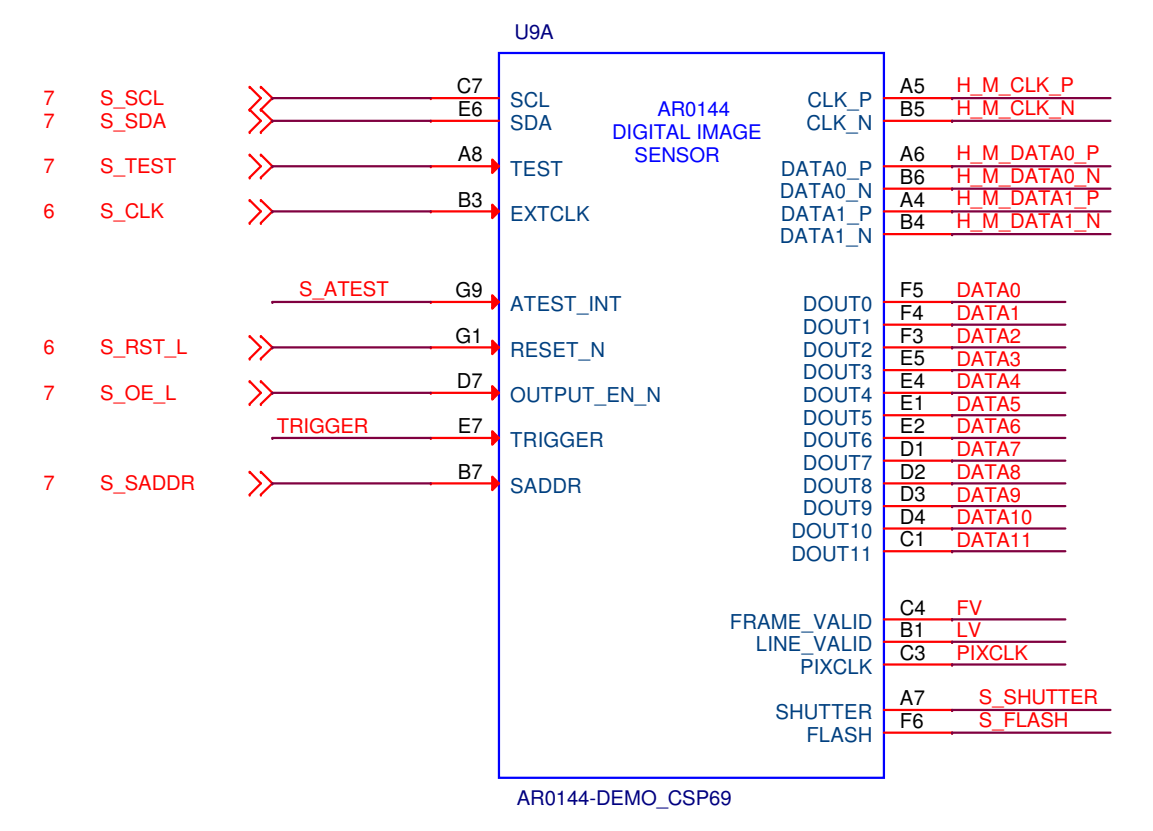
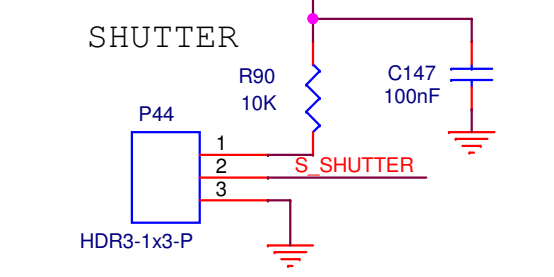

(Note for layout: - Place these testpads near the Demo3 I/F connector at the top side of PCB)

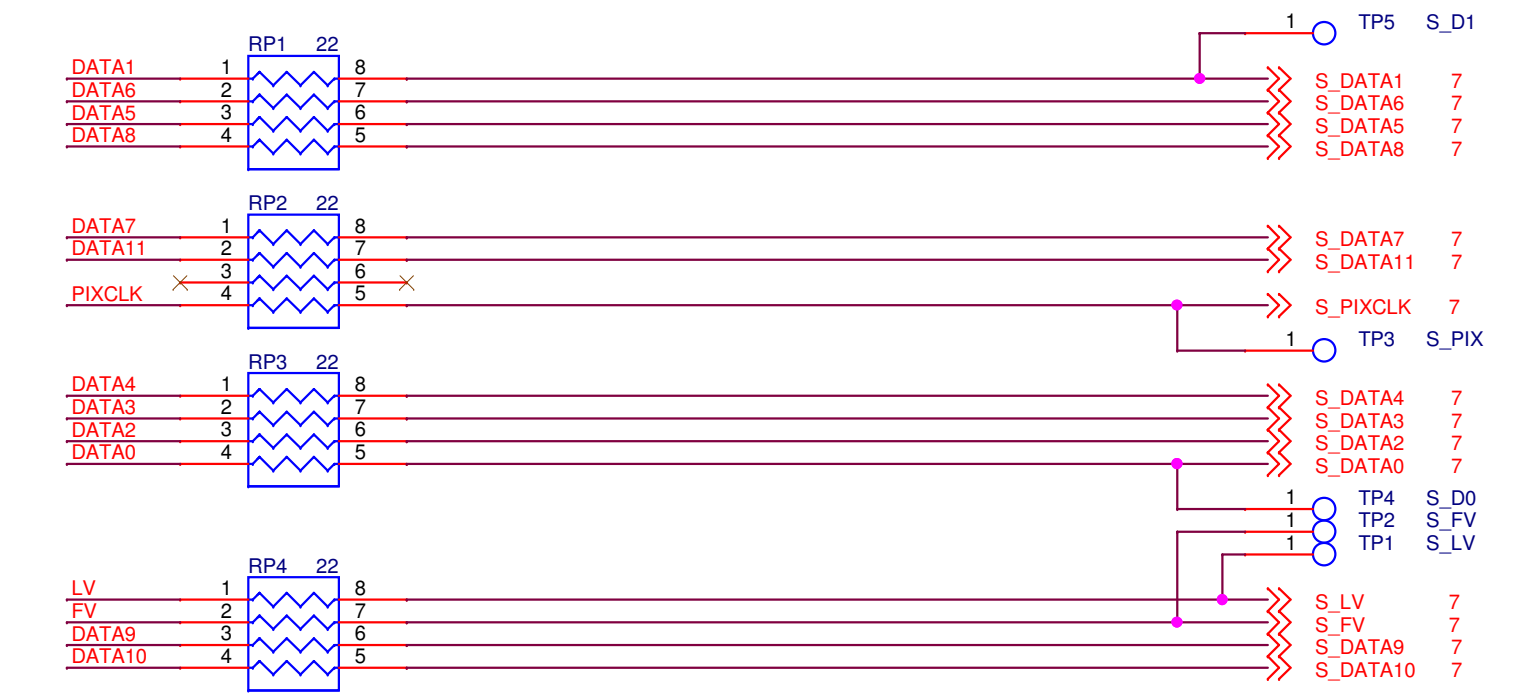
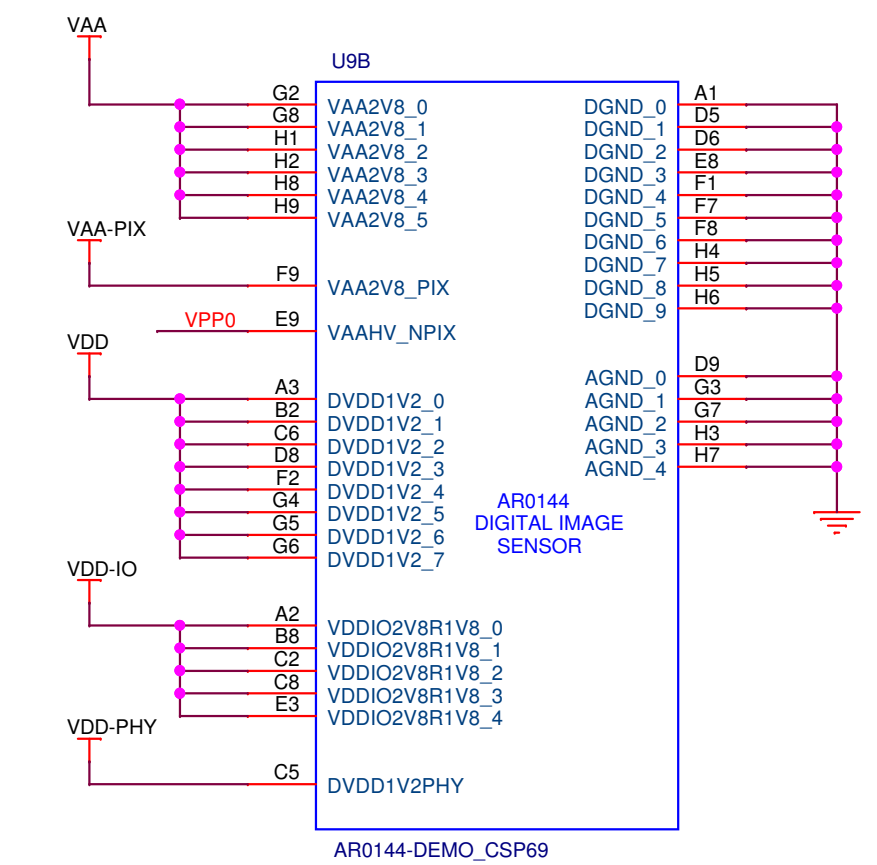
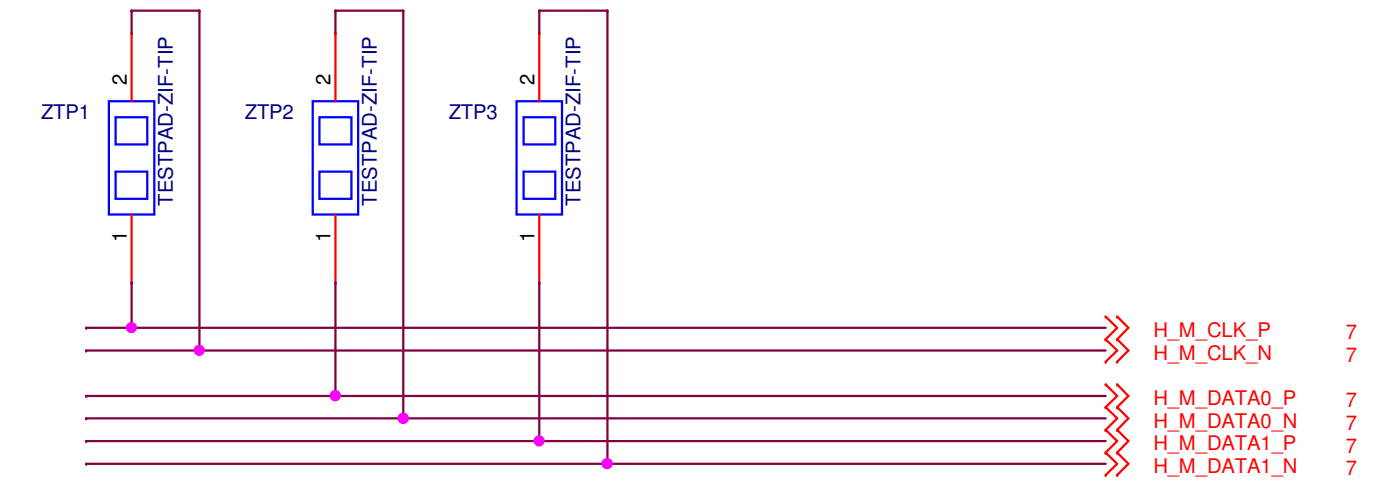

Tripod Mount

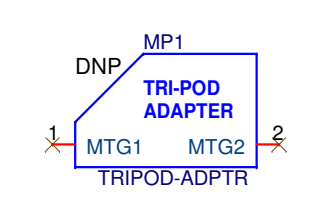

Socket/Lens Mount

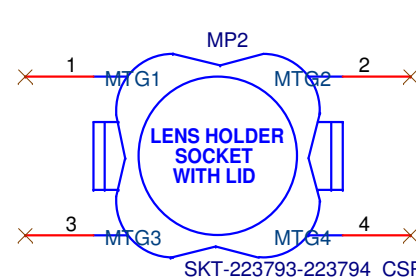

ON ON Semiconductor®

Title: Sensor

Size C Document Name: AR0144-CSP_Demo3Head Rev: 0.2

Date: Monday, November 09, 2015 Sheet: 4 of 7

Debug Headers: Cut away the shorted trace and mount header for power debugging

Power

VDD 1.2V SUPPLY

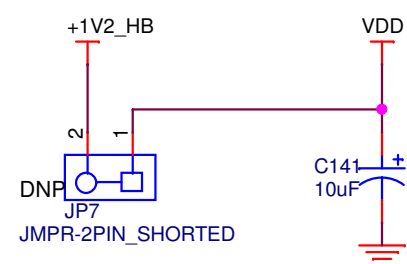

VDD-PHY 1.2V SUPPLY

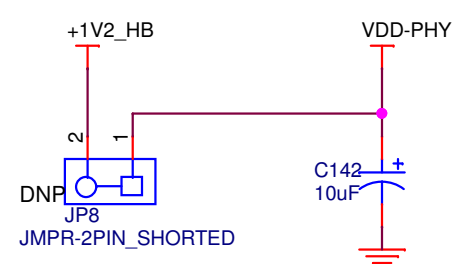

VAA 2.8V SUPPLY

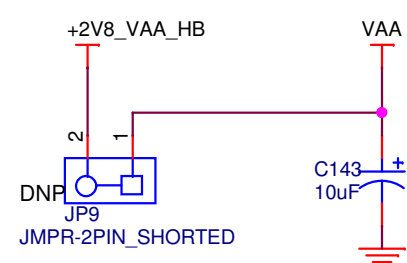

VAA-PIX 2.8V SUPPLY

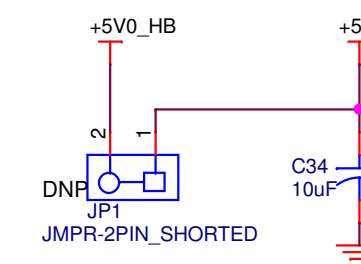
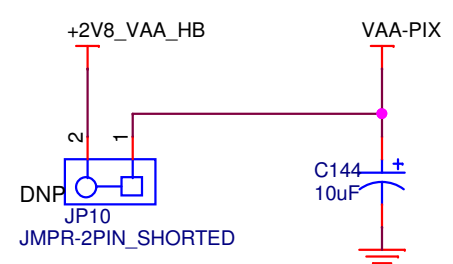

PERIPHERAL 3.3V SUPPLY

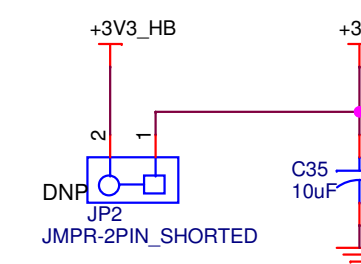

VDDIO & VDDIO_LS 1.8V/2.8V SUPPLY

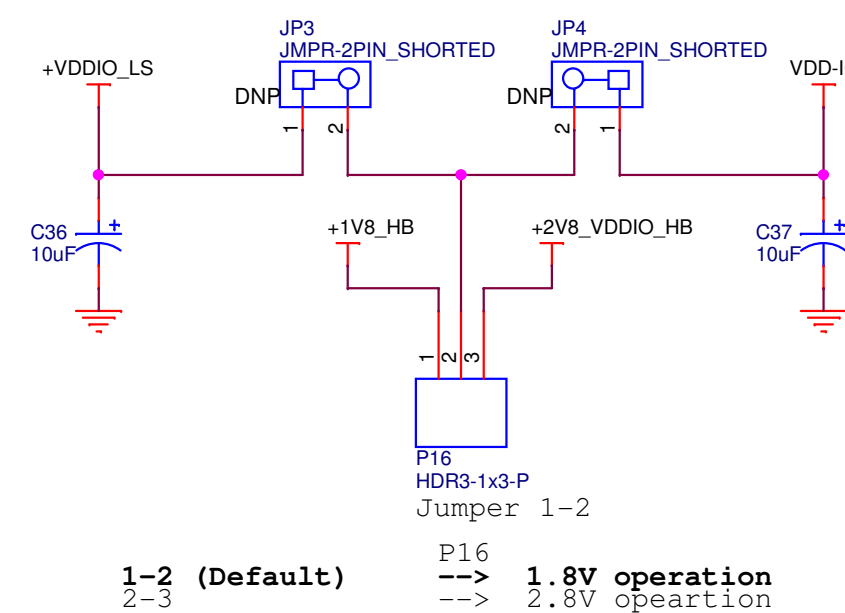

+5V0_HB	7	+5V0_HB	7
+3V3_HB	7	+3V3_HB	7
+2V8_VAA_HB	4,7	+2V8_VAA_HB	4,7
+2V8_VDDIO_HB	7	+2V8_VDDIO_HB	7
+1V8_HB	7	+1V8_HB	7
+1V2_HB	7	+1V2_HB	7
+5V0	4	+5V0	4
+3V3	4,6	+3V3	4,6
+VDDIO_LS	6,7	+VDDIO_LS	6,7
4	VDD	VDD	
4	VDD-PHY	VDD-PHY	
4	VDD-IO	VDD-IO	
4	VAA	VAA	
4	VAA-PIX	VAA-PIX	

5V LED

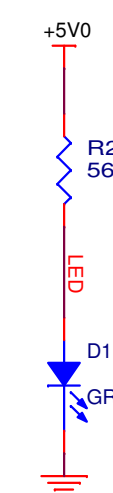

Layout Note
(Mount LED on
bottom side of PCB)

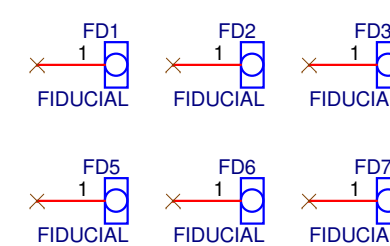

Ground Testpoints

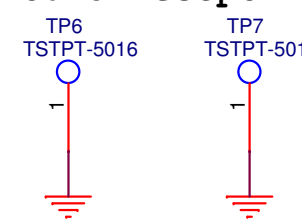

Mounting Holes

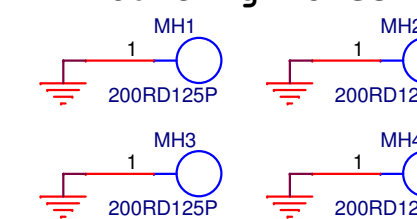



ON Semiconductor

Title		Power
Size	Document Name	Rev
C	AR0144-CSP_Demo3Head	0.2
Date:	Wednesday, November 04, 2015	Sheet 5 of 7

Clock and Reset

+5V0	4,5
+3V3	4,5
+VDDIO_LS	5,7

CLOCK CIRCUIT

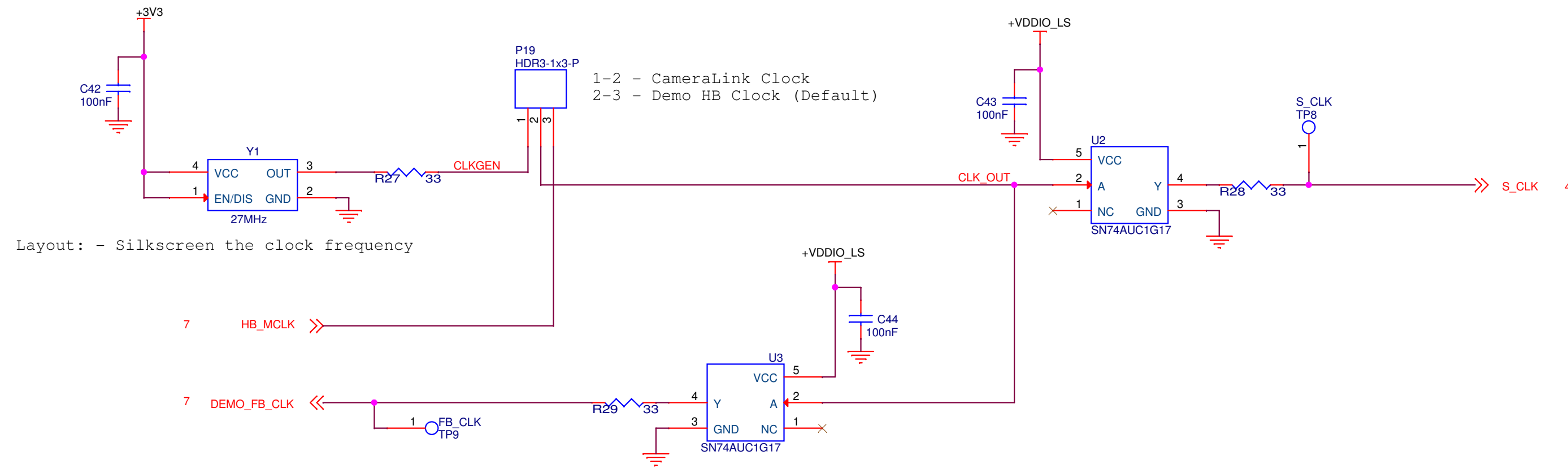

RESET CIRCUIT

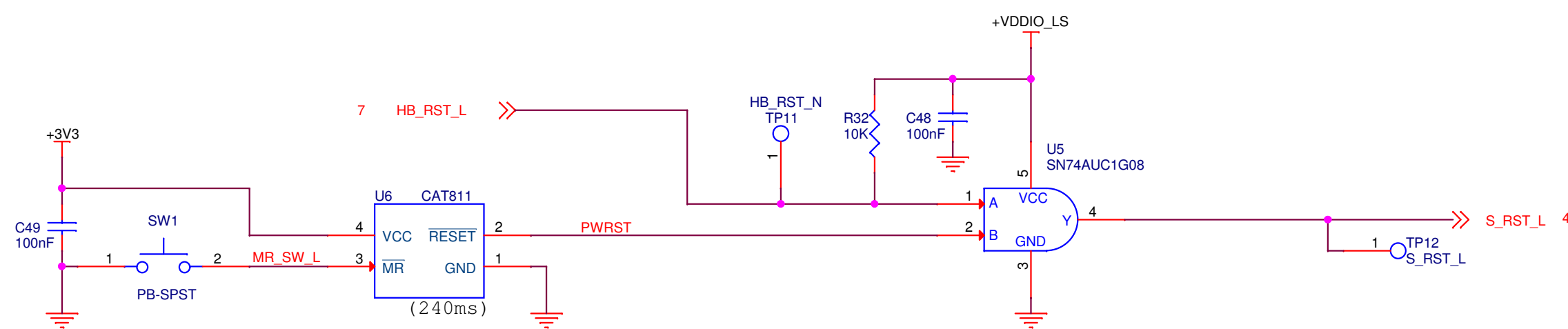

ON Semiconductor®

Title		
Clock and Reset		
Size	Document Name	Rev
C	AR0144-CSP_Demo3Head	0.2
Date:	Monday, November 09, 2015	Sheet 6 of 7

External Interface

+5V0_HB	5	+5V0_HB	5
+3V3_HB	5	+3V3_HB	5
+2V8_VAA_HB	4,5	+2V8_VAA_HB	4,5
+2V8_VDDIO_HB	5	+2V8_VDDIO_HB	5
+1V8_HB	5	+1V8_HB	5
+1V2_HB	5	+1V2_HB	5
+3V3_VDDIO_LS	4,5,6	+3V3_VDDIO_LS	4,5,6
+VDDIO_LS	5,6	+VDDIO_LS	5,6

DEMO3 BASEBOARD I/F

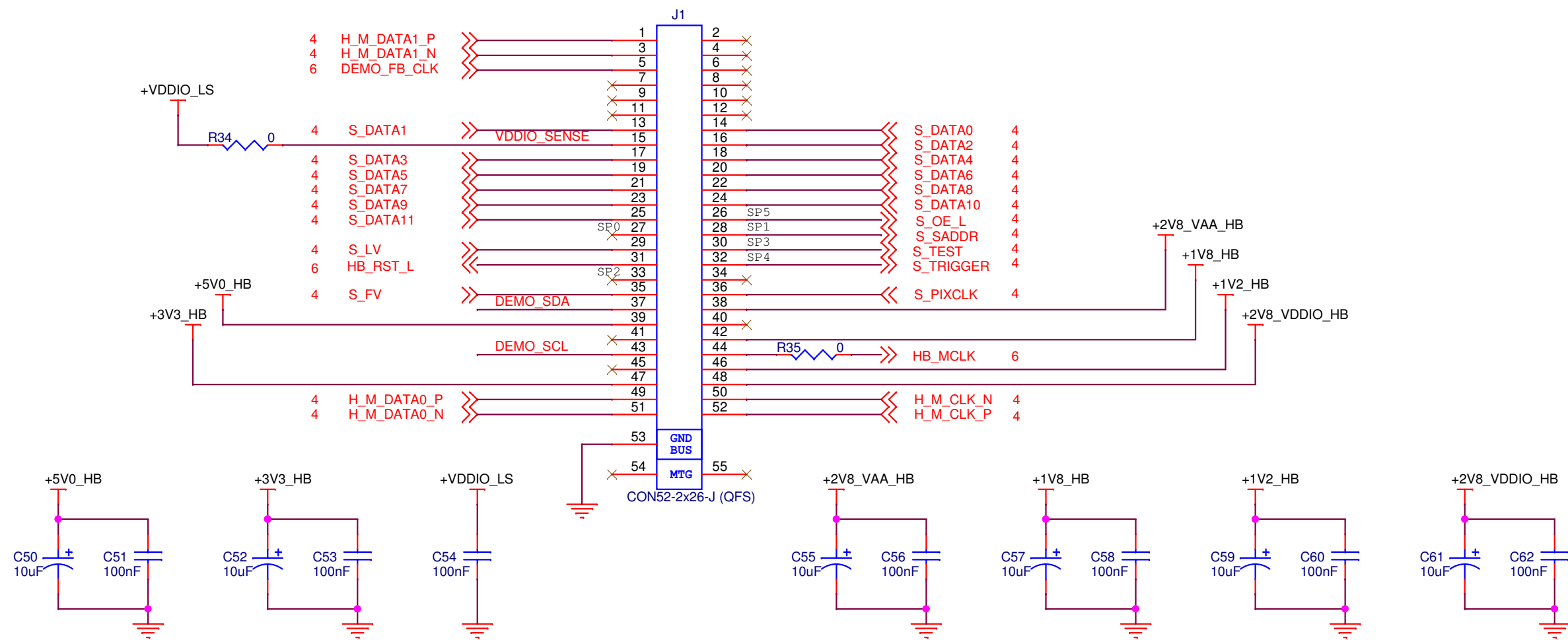

I2C DEBUG

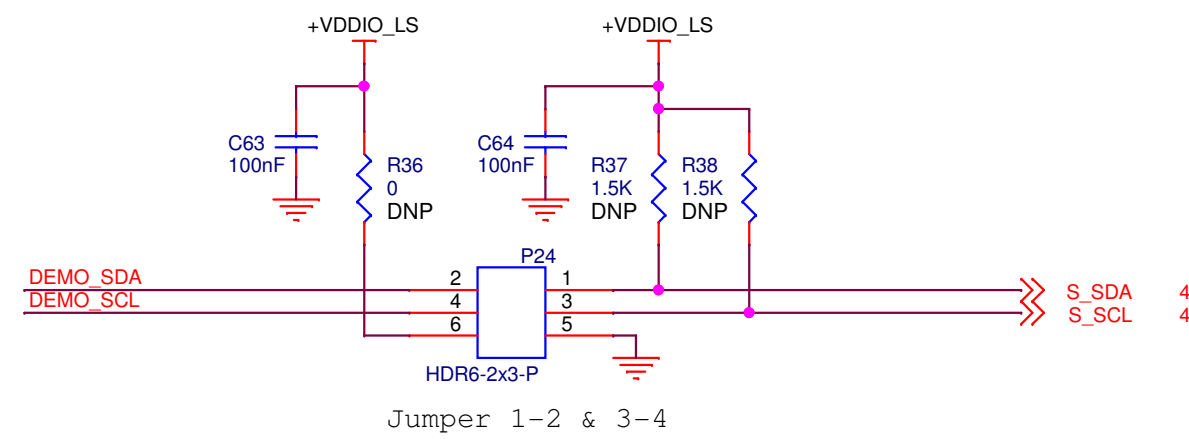

LENS CORRECTION EEPROM

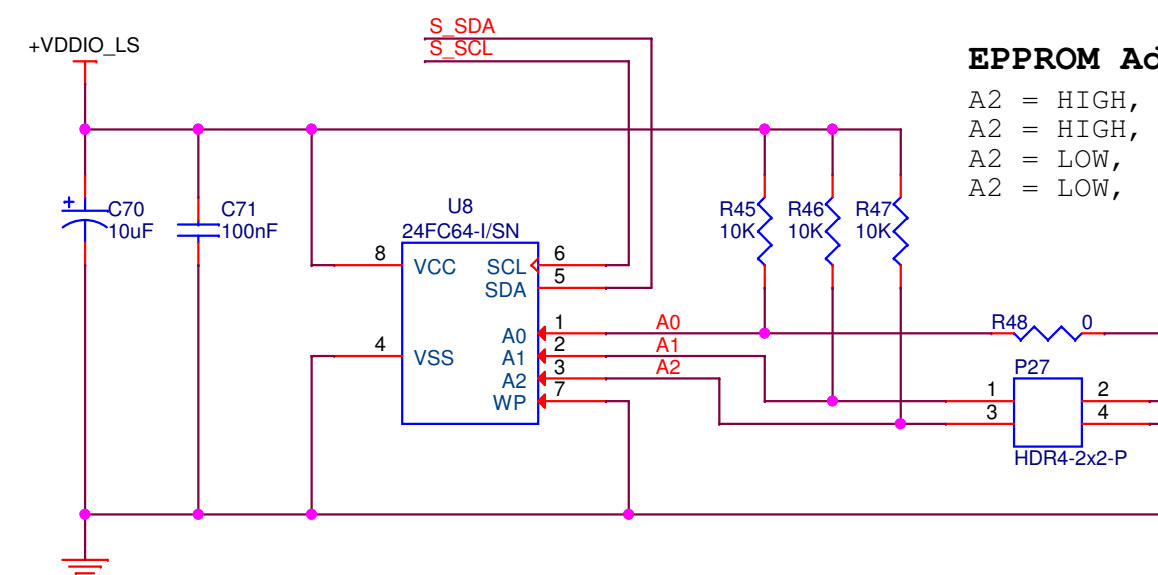

EPPROM Address Switch Settings:
 A2 = HIGH, A1 = LOW, A0 = LOW; Address => 0xA8 (default)
 A2 = HIGH, A1 = HIGH, A0 = LOW; Address => 0xAC
 A2 = LOW, A1 = HIGH, A0 = LOW; Address => 0xA4
 A2 = LOW, A1 = LOW, A0 = LOW; Address => 0xA0



ON Semiconductor®		
Title	External Interface	
Size	Document Name	Rev
C	AR0144-CSP_Demo3Head	0.2
Date:	Wednesday, November 04, 2015	Sheet 7 of 7

Mouser Electronics

Authorized Distributor

Click to View Pricing, Inventory, Delivery & Lifecycle Information:

[ON Semiconductor:](#)

[AR0144CSSM20SUKAH3-GEVB](#)