

Programmable Current Limit Switches

FEATURES

- Wide input voltage range from 2.7V to 6.5V
- Maximum input DC voltage is 24V
- Integrated low $R_{ds(on)}$ switch: 50m Ω
- Programmable current limit from 250mA to 3A
- $\pm 7\%$ current limit accuracy at $T_A=+25^\circ\text{C}$
- 7.5V input overvoltage shutdown
- 150ns overvoltage lockout response
- 5.4V overvoltage clamp
- Built-in soft start
- Thermal shutdown protection
- Fault output
- Enable interface pin
- DFN 2mmx2mmx0.75mm-6L

APPLICATIONS

- White goods, Appliances
- Set-top boxes, DVD and Gaming consoles
- HDD and SSD drives
- Adapter power devices
- Smart meters, Gas analyzers
- Smart load switches/USB switches

GENERAL DESCRIPTION

AW35019A is a smart e-Fuse with robust overcurrent and overvoltage protection. The wide operating voltage allows control of many popular DC buses.

AW35019A uses N-channel MOSFET as power switch, and allows the user to program the current-limit threshold between 250mA to 3A with an external resistor when the load exceeds the current-limit threshold.

AW35019A can withstand 24V DC voltage. In the event that an incorrect voltage is IN, the output clamps to 5.4V to protect the load. If the voltage at IN exceeds 7.5V, the device disconnects the load to prevent damage to the device and/or load.

Additional features include enable, under-voltage, over-temperature, output discharge and fault flag output are provided to monitor system status.

TYPICAL APPLICATION CIRCUIT

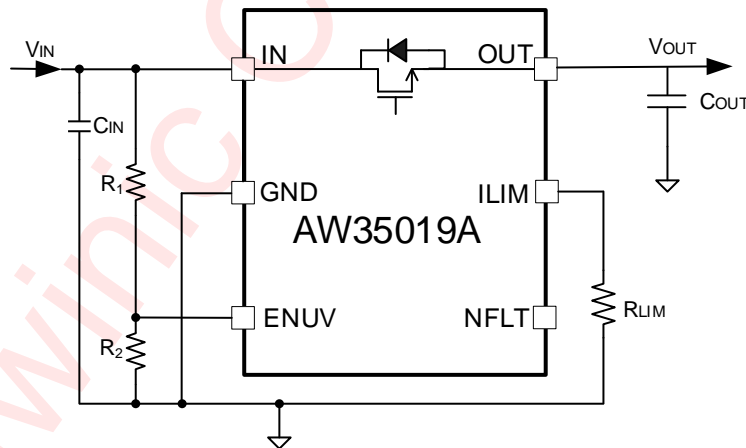

Figure 1 Typical application circuit

Pin Configuration

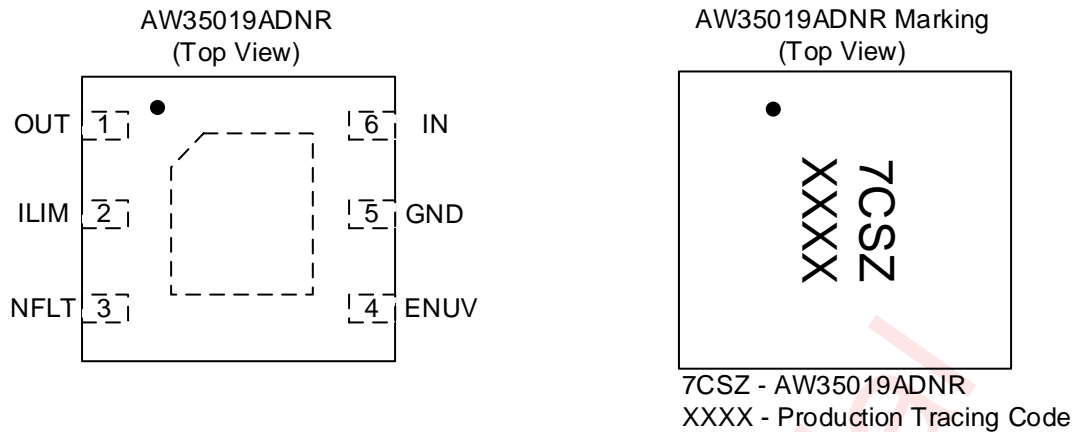

Figure 2 Pin Configuration

PIN DEFINITION

Pin	Name	Description
1	OUT	Power output.
2	ILIM	A resistor from this pin to GND. Setting threshold of limit current.
3	NFLT	Active-low open-drain output, connect a pull up resistor to high. Asserted low during over voltage, UVLO, short circuit, over temperature, fast-trip and current limit.
4	ENUV	Logic-level control input. When this pin is driven high, the power switch is enabled. When this pin is driven low, the power switch turns off. This pin can set the programmable threshold of UVLO.
5	GND	Ground.
6	IN	Power input, supply voltage of the device.

FUNCTIONAL BLOCK DIAGRAM

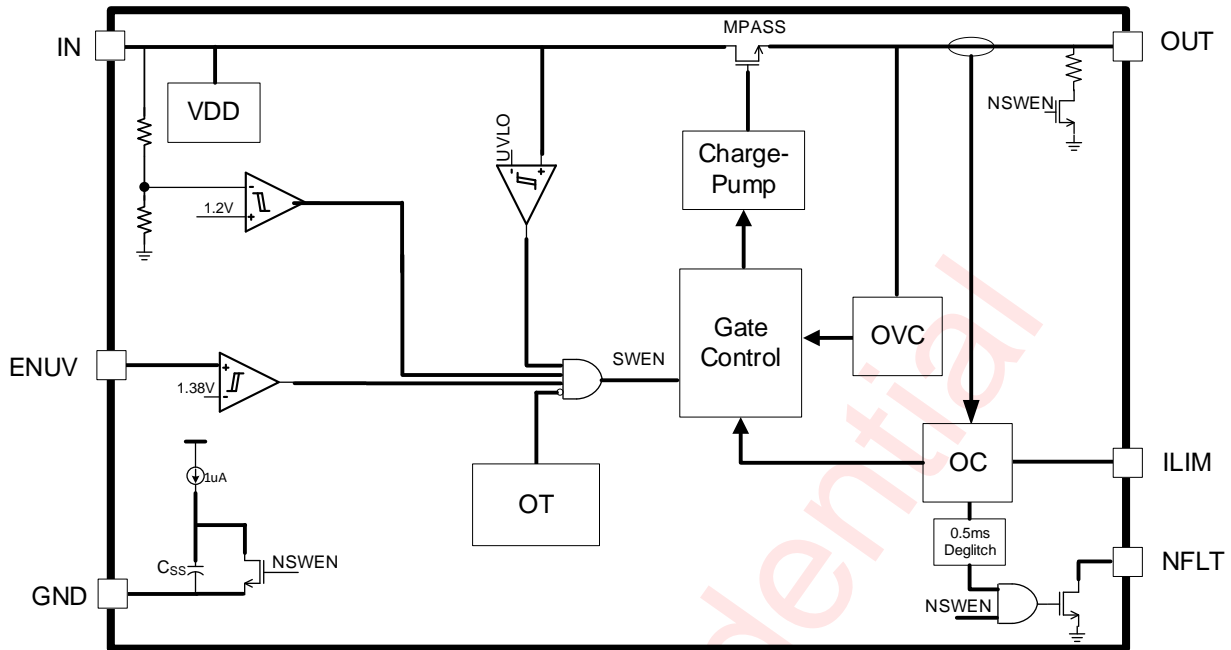

Figure 3 Functional Block Diagram

TYPICAL APPLICATION CIRCUITS

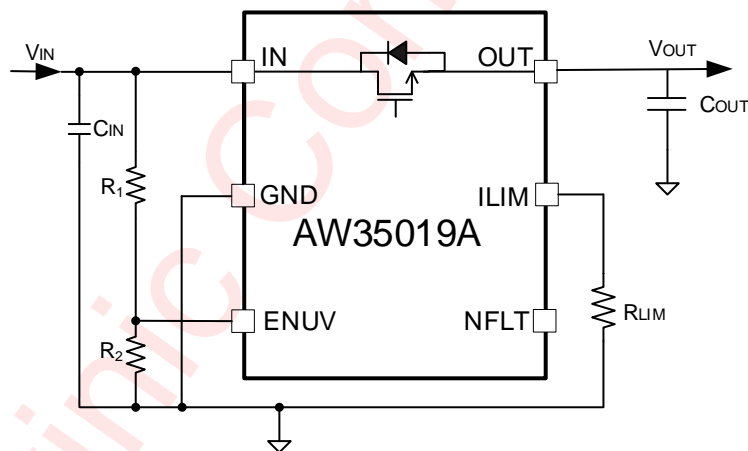

Figure 4 Application circuit

Notice for Typical Application Circuits:

1. Place C_{IN} as close as possible to IN.
2. Place C_{OUT} as close as possible to OUT.
3. Place R_{LIM} as close as ILIM.
4. If NFLT is not used, it can be left floating.
5. IN, OUT support 3A current, the connection lines should be as wide as possible.

ORDERING INFORMATION

Part Number	Temperature	Package	Marking	Moisture Sensitivity Level	Environmental Information	Delivery Form
AW35019ADNR	-40°C ~ 85°C	DFN 2mmx2mm-6L	7CSZ	MSL1	ROHS+HF	3000 units/ Tape and Reel

ABSOLUTE MAXIMUM RATINGS (NOTE 1)

Symbol	Parameter	Condition	Min.	Max.	Unit
V _{IN}	Power voltage		-0.3	28	V
V _{OUT}	OUT voltage		-0.3	28	V
V _{ENUV}	ENUV input voltage		-0.3	28	V
V _{NFLT}	NFLT output voltage		-0.3	28	V
V _{ILIM}	ILIM voltage		-0.3	6	V
T _{JMAX}	Maximum operating junction temperature			140	°C
T _{STG}	Storage temperature		-65	150	°C
T _{LEAD}	Soldering temperature	At leads, 10 seconds		260	°C

NOTE1: Conditions out of those ranges listed in “absolute maximum ratings” may cause permanent damages to the device. In spite of the limits above, functional operation conditions of the device should within the ranges listed in “recommended operating conditions”. Exposure to absolute-maximum-rated conditions for prolonged periods may affect device reliability.

THERMAL INFORMATION

Symbol	Parameter	Condition	Value	Unit
R _{θJA}	Thermal resistance from junction to ambient <small>(NOTE 1)</small>	In free air	78	°C/W

NOTE1: Thermal resistance from junction to ambient is highly dependent on PCB layout.

ESD AND LATCH-UP RATINGS

Symbol	Parameter	Condition	Value	Unit
V _{ESD}	Human body model	ESDA/JEDEC JS-001-2017	±2	kV
	Charged device model	ESDA/JEDEC JS-002-2018	±1.5	kV
I _{Latch-up}	Latch up	JESD78E	±200	mA

RECOMMENDED OPERATING CONDITIONS

Symbol	Parameter	Min.	Typ.	Max.	Unit
V _{IN}	Power voltage	2.7		6.5	V
V _{ENUV}	ENUV input voltage	0		6.5	V
V _{NFLT}	NFLT output voltage	0		5.5	V
V _{ILIM}	ILIM voltage	0		5.5	V
I _{OUT}	Current limit	0.25		3	A
T _A	Ambient temperature	-40		85	°C

ELECTRICAL CHARACTERISTICS

$T_A = -40^{\circ}\text{C}$ to 85°C , $V_{IN} = 2.7\text{V}$ to 6.5V , $V_{ENUV}=2\text{V}$, $R_{ILIM}=100\text{k}\Omega$, $C_{IN} = 0.1\mu\text{F}$, $C_{OUT} = 1\mu\text{F}$, unless otherwise noted.

Symbol	Description	Test Conditions	Min.	Typ.	Max.	Unit
Power supply and internal UVLO						
V_{UVLO}	Power under voltage lockout	V_{IN} rising	2.45	2.55	2.65	V
V_{UVLO_HYS}	Power under voltage lockout hysteresis			100		mV
I_{Q_OFF}	Supply current, disable	$V_{ENUV}=0\text{V}$, $V_{IN}=5\text{V}$		0.4	1	μA
I_{Q_ON}	Supply current, enable	$V_{ENUV}=2\text{V}$, $V_{IN}=5\text{V}$		370	500	μA
Input over-voltage protection						
V_{IN_OVLO}	OVP trip level	V_{IN} rising	7	7.5	8	V
		Hysteresis		0.12		V
Enable and under voltage lockout input(ENUV)						
V_{ENR}	ENUV threshold voltage, rising		1.33	1.38	1.46	V
V_{ENF}	ENUV threshold voltage, falling		1.27	1.33	1.39	V
I_{EN}	EN input leakage current	$0\text{V} \leq V_{ENUV} \leq 5\text{V}$		0	0.5	μA
Discharge						
R_{DCHG}	OUT discharge resistance	$V_{OUT}=5\text{V}$, $V_{ENUV}=0\text{V}$		600		Ω
Power MOSFET switch						
R_{ON}	Switch on resistance	$I_{OUT}=0.1\text{A}$	30	50	70	m Ω
Current limit programming (ILIM)						
I_{LIM}	Current limit	$R_{ILIM}=50\text{k}\Omega$, $T_A=25^{\circ}\text{C}$	1.86	2.00	2.14	A
		$R_{ILIM}=200\text{k}\Omega$, $T_A=25^{\circ}\text{C}$	0.45	0.50	0.55	A
		$R_{ILIM}=300\text{k}\Omega$, $T_A=25^{\circ}\text{C}$	0.28	0.33	0.38	A
$I_{FAST-TRIP}$	Fast-trip comparator threshold	R_{ILIM} in k Ω			$2 \times I_{LIM}$	A
Voltage Clamp, OUT						
V_{OVC}	OUT clamp voltage threshold	$C_{OUT} = 1\mu\text{F}$, $R_L=100\Omega$, $V_{IN}=6.5\text{V}$	5.0	5.4	5.9	V

ELECTRICAL CHARACTERISTICS (CONTINUED)

$T_A = -40^{\circ}\text{C}$ to 85°C unless otherwise noted. Typical values are guaranteed for $V_{IN} = 2.7\text{V}$ to 6.5V , $C_{IN} = 0.1\mu\text{F}$, $C_{OUT} = 1\mu\text{F}$, $V_{ENUV} = 2\text{V}$, $R_{ILIM} = 100\text{k}\Omega$, unless otherwise noted.

Symbol	Description	Test Conditions	Min.	Typ.	Max.	Unit
Fault flag(NFLT): active low						
RNFLT	NFLT pull down resistance	$V_{ENUV} = 0\text{V}$, $I_{NFLT} = 100\text{mA}$	19	27	35	Ω
INFLT	NFLT input leakage current	Device not in fault condition, $V_{NFLT} = 0\text{V}$, 5V		0	0.5	μA
Thermal shutdown						
T_{SDN}	Thermal shutdown threshold	Temperature rising		140		$^{\circ}\text{C}$
T_{SDN_HYS}	Hysteresis	Temperature falling		20		$^{\circ}\text{C}$
Enable and under voltage lockout input						
t_{OFF_DLY}	Turn off delay	$E_{NUV} = 0$ to V_{OUT} falling		3		μs
t_{ON_DLY}	Turn on delay	$E_{NUV} = 1$ to $V_{OUT} = 1\text{V}$		170		μs
Over voltage protection input						
t_{OVP_DLY}	Turn off delay for OVLO	$C_{OUT} = 1\mu\text{F}$, $R_L = 100\Omega$, $V_{IN} > V_{IN_OVLO}$ to V_{OUT} stop rising, V_{IN} initial 5V , 20V surge test, $T_A = 25^{\circ}\text{C}$		150		ns
Current limit programming(ILIM)						
$t_{FAST_TRIP_DLY}$	Fast trip comparator delay	$I_{OUT} > I_{FAST_TRIP}$		1		μs
Thermal shutdown(TSD)						
t_{TSD_DLY}	Retry delay after thermal shutdown recovery	$V_{IN} = 5\text{V}$		130		ms
Fault flag(NFLT): active low						
t_{NFLT}	NFLT assertion due to overcurrent condition			1		ms

TIMING DIAGRAM

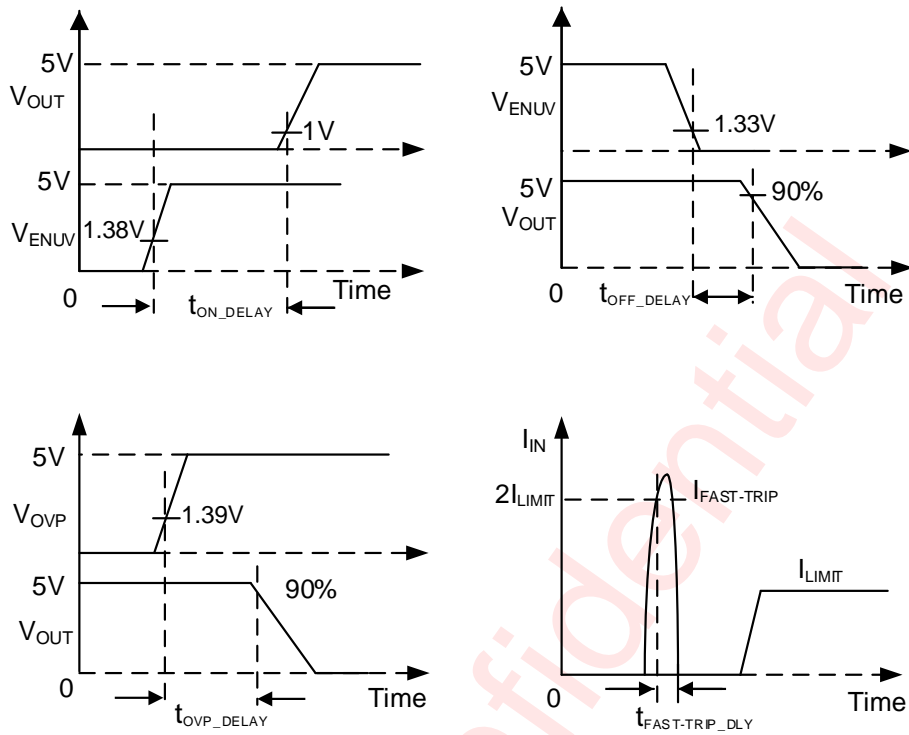

Figure 5 Timing Diagram

TYPICAL CHARACTERISTICS

Ambient temperature is 25°C, $V_{IN}=2.7V$ to $24V$, $C_{IN} = 0.1\mu F$, $C_{OUT} = 1\mu F$, $V_{ENUV}=2V$, $R_{ILIM}=100k\Omega$, unless otherwise noted.

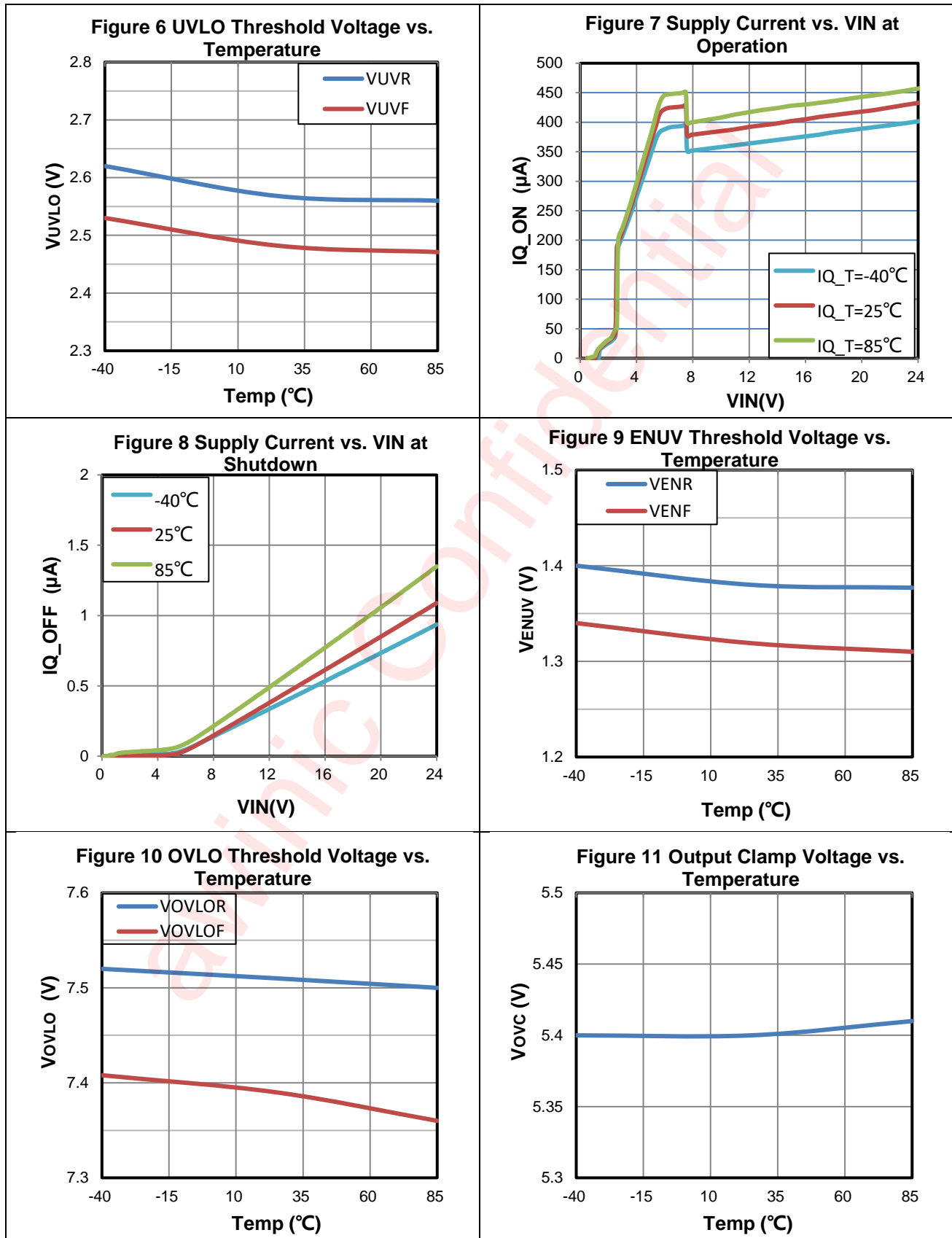

Figure 12 Output Ramp Time vs. Temperature

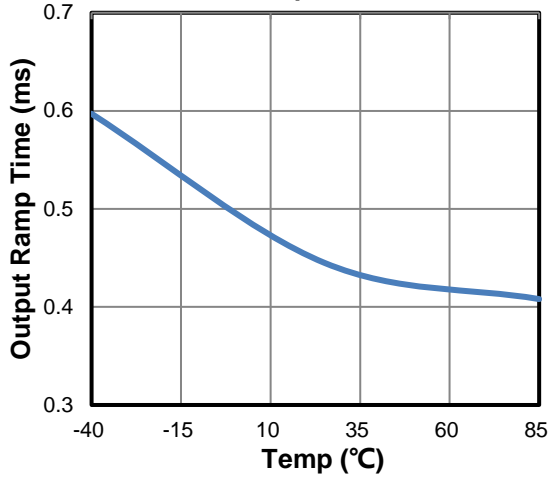

Figure 13 Current Limit vs. Temperature

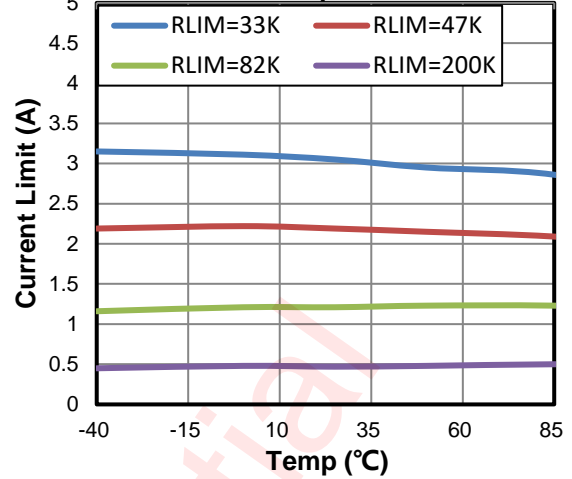

Figure 14 RDSON vs. Temperature

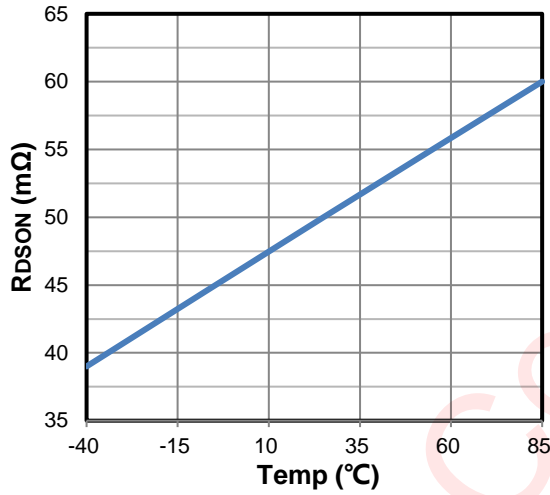

Figure 15 Current Limit vs. Current Limit Resistor

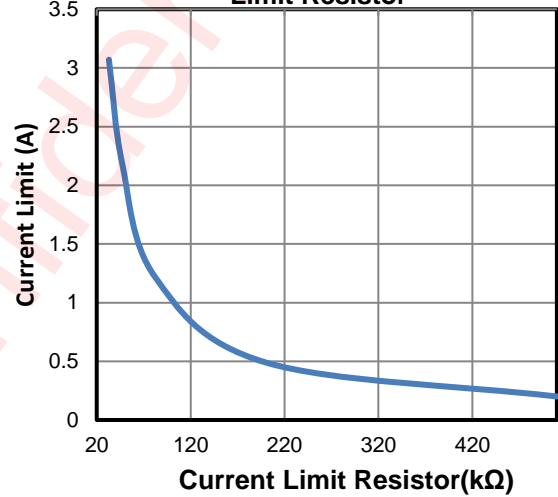

Figure 16 ENUV Turn-On Delay: ENUV↑ to Output Ramp↑

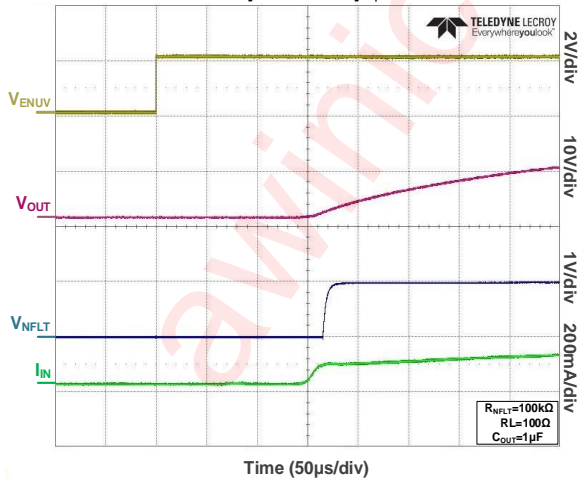
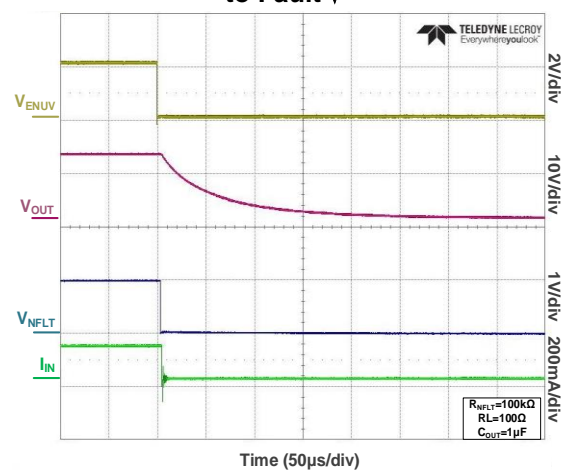

Figure 17 ENUV Turn-Off Delay: ENUV ↓ to Fault ↓



DETAILED FUNCTIONAL DESCRIPTION

The AW35019A is a smart e-Fuse with enhanced built-in protection circuitry. It provides robust protection for all systems and applications powered from 2.7V to 6.5V.

For hot-plug-in boards, the device provides in-rush current control and programmable output ramp rate. AW35019A integrate over-current and short-circuit protections. The precision over-current limit helps to minimize over design of the input power supply, while the fast response short-circuit protection immediately isolates the load from input when a short circuit is detected. The device allows the user to program the over-current limit threshold between 0.25A and 3A via an external resistor. The device provides precision monitoring of voltage bus for brown-out and over-voltage conditions of voltage bus for brown-out and over-voltage conditions and asserts fault for downstream system. AW35019A is designed to protect systems such as White Goods, STBs, DTVs, Smart Meters and Gas Analyzers.

The additional features include:

Over-temperature protection to safely shutdown in the event of an over-current event.

Fault reporting for brown-out and over voltage, UVLO, short circuit, over temperature, fast-trip and current limit.

Enable

ENUV enables the control circuits, and power switch when $V_{ENUV} > 1.38V$. It turns off power switch when $V_{ENUV} < 1.33V$. When V_{ENUV} is low, it will reset AW35019A that have latched off due to a fault condition.

Over-voltage protection

AW35019A has internal over-voltage protection, and its threshold voltage is 7.5V. When over voltage event happens, power switch is turned off to protect downstream load.

Over-load and short-circuit protection

Load current is monitored by sensing voltage across an internal sense resistor. Current limit threshold is programmed by connecting external resistor R_{LIM} to GND.

$$I_{LIM} = 1.0 * 10^5 / R_{LIM}$$

When over load happens, current is limited to the current limit threshold. If current limit keeps on for 0.5ms, current limit decreases to I_{LIM_ST} . I_{LIM_ST} is start-up current limit value. During soft-start, power switch current limit value I_{LIM_ST} is small, I_{LIM_ST} is about 50%* I_{LIM} .

But when a transient short-circuit event happens, the current through the device increases very rapidly. Current limit amplifier cannot respond quickly. So a fast-trip comparator is also integrated to shut down power switch within 1 μ s. The fast-trip threshold current is $2 * I_{LIM}$. Fast-trip comparator shuts down power switch for only a few microseconds, then the device attempts to soft start power switch.

Output-voltage clamp (OVC)

When $5.4V < V_{IN} < 7.5V$, the output-voltage clamp (OVC) circuit clamps the output voltage to 5.4V. Within this V_{IN} range, the over-current protection remains active, but current limit is I_{LIM_ST} .

NFLT Fault Report

NFLT pin is asserted low during over-voltage, under-voltage, thermal shut down, over load and current limit. It is de-asserted after the fault condition is removed and then recover normal operation. It's recommended to be pulled up by 100k Ω pull-up resistor to input. During normal operation, NFLT is pulled up to logic high by pull-up resistor, when fault event happens, NFLT will output logic low.

Thermal shutdown

When the junction temperature rises to approximately 140°C, thermal shutdown (TSD) protection turns off the load switch for cooling the device until the junction temperature falls to approximately 120°C.

Output discharge

A discharge resistor with 600Ω is connected to the OUT terminal when power switch is turned off. The discharge resistor dissipates stored charge and leakage current on OUT. The pull-down capability decreases as V_{IN} decreases.

awinic Confidential

PCB LAYOUT CONSIDERATION

To obtain the optimal performance of AW35019A, PCB layout should be considered carefully. Here are some guidelines:

1. Place C_{IN} as close as possible to IN.
2. Place C_{OUT} as close as possible to OUT.
3. Place R_{LIM} as close as ILIM.
4. IN, OUT support 3A current, the connection lines should be as wide as possible.
5. Connect the IN and OUT pads to a large IN and OUT plane respectively to achieve better thermal performance.

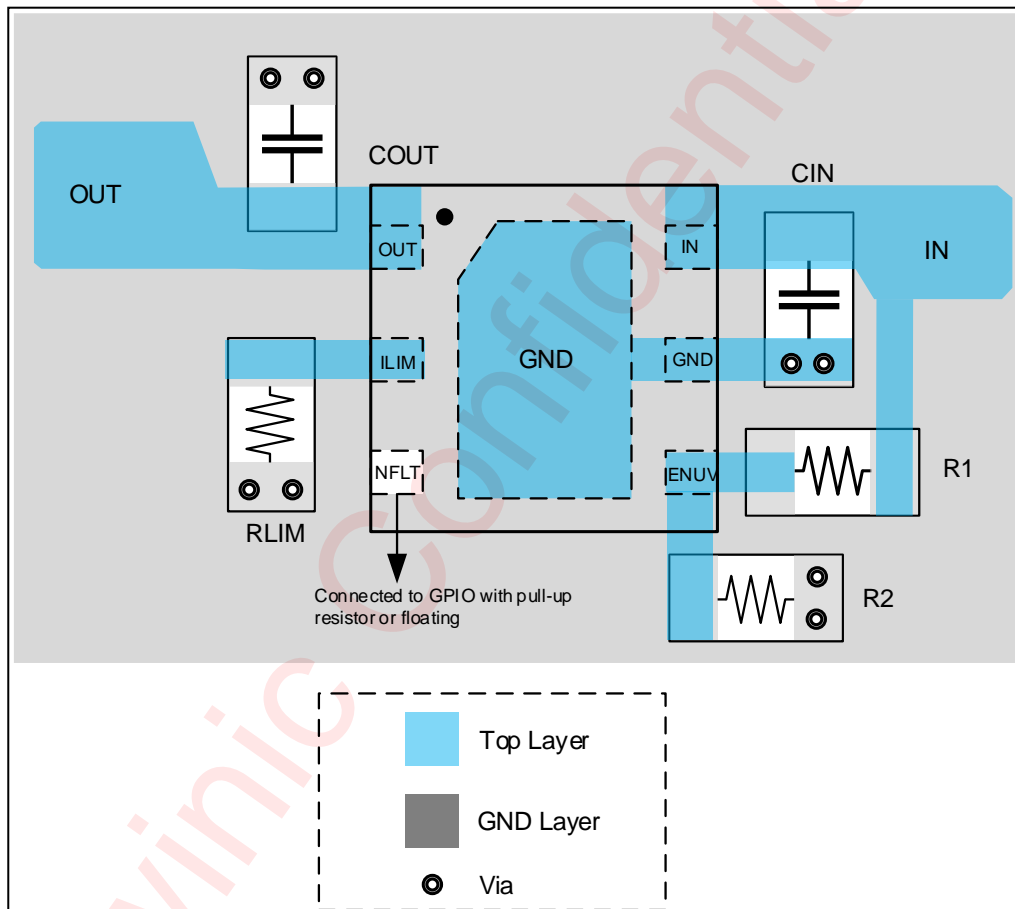
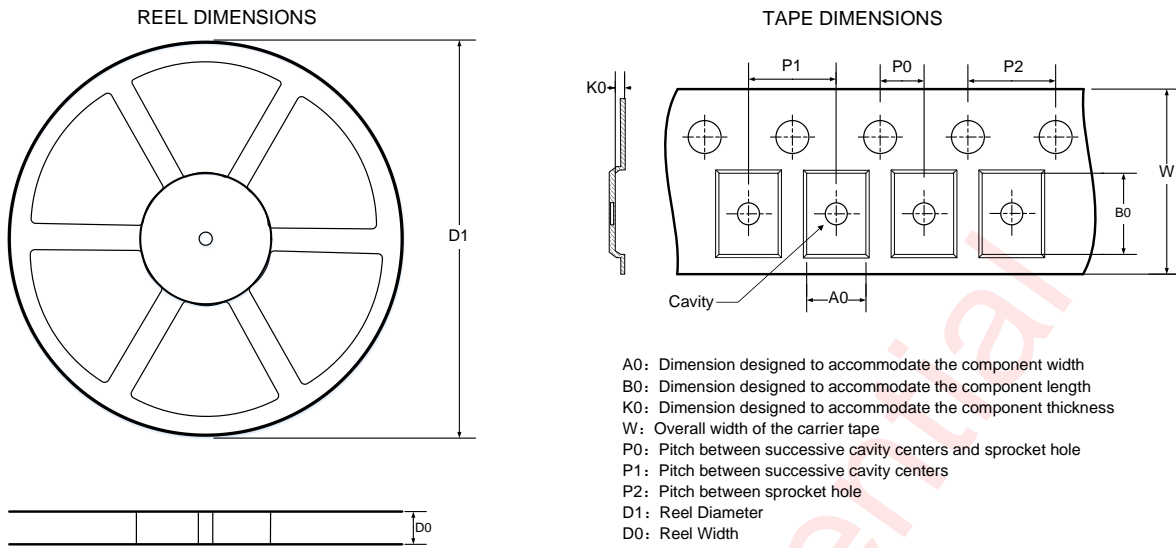
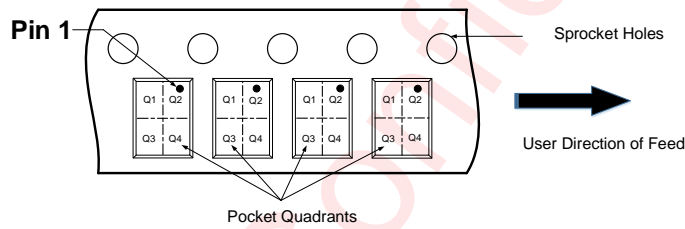

Figure 18 External Components Placements and PCB Layout Example

TAPE AND REEL INFORMATION



QUADRANT ASSIGNMENTS FOR PIN 1 ORIENTATION IN TAPE



Note: The above picture is for reference only. Please refer to the value in the table below for the actual size

DIMENSIONS AND PIN1 ORIENTATION

D1 (mm)	D0 (mm)	A0 (mm)	B0 (mm)	K0 (mm)	P0 (mm)	P1 (mm)	P2 (mm)	W (mm)	Pin1 Quadrant
178	8.4	2.25	2.25	0.95	2	4	4	8	Q2

All dimensions are nominal

PACKAGE DESCRIPTION

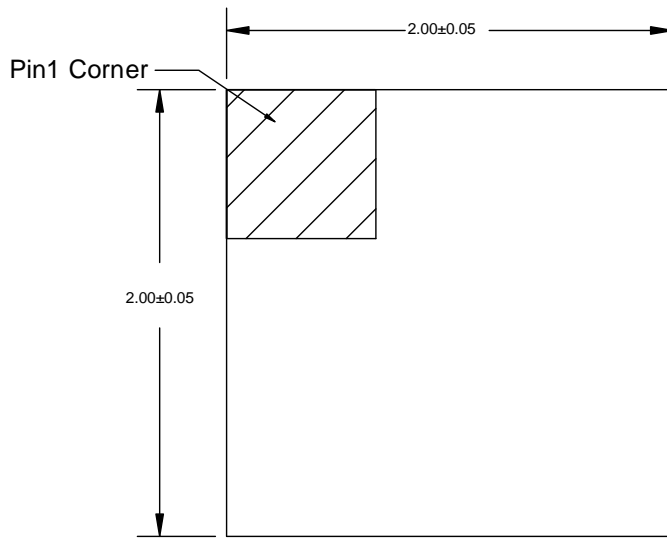

Top View

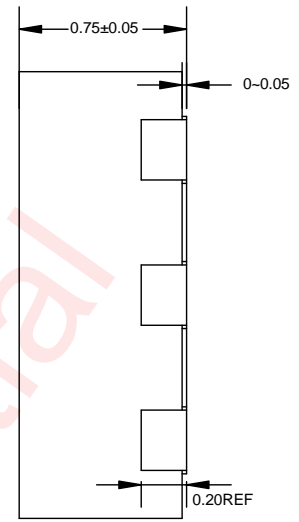

Side View



Side View

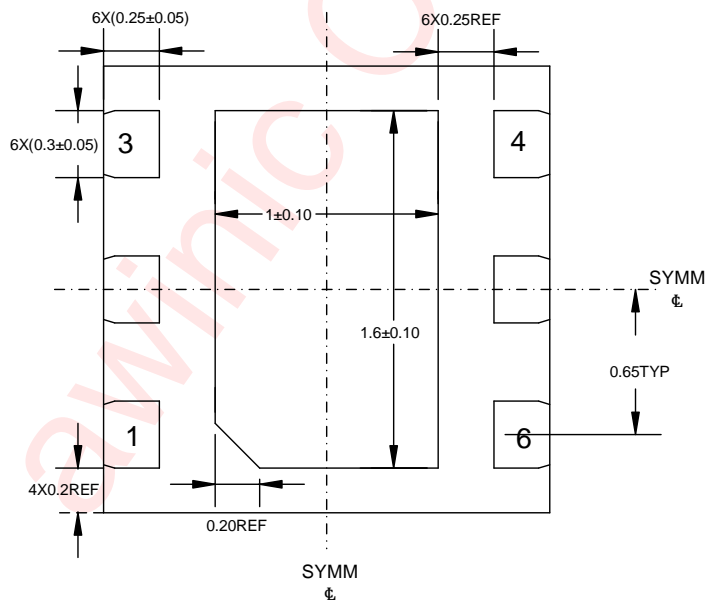

Bottom View

Unit: mm

LAND PATTERN DATA

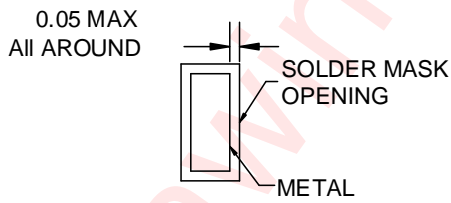
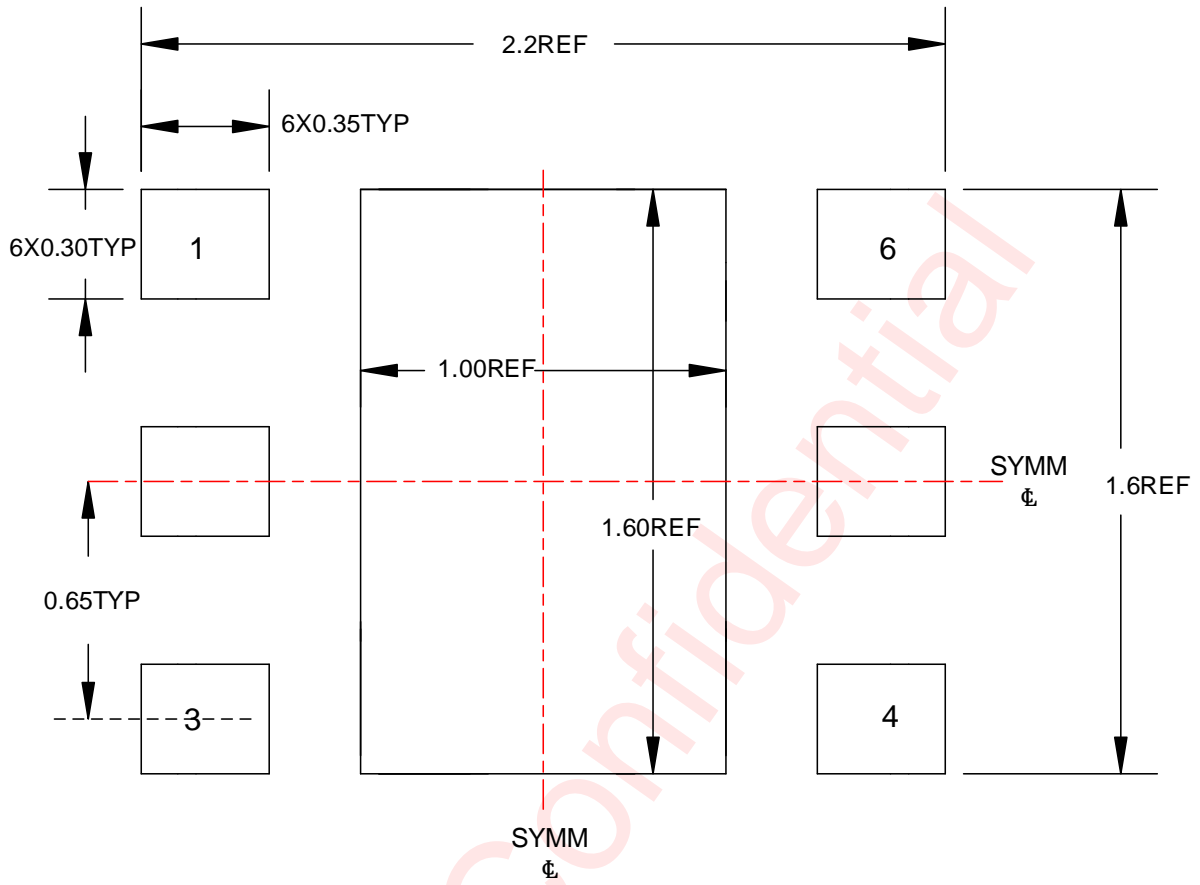

NON SOLDER MASK DEFINED

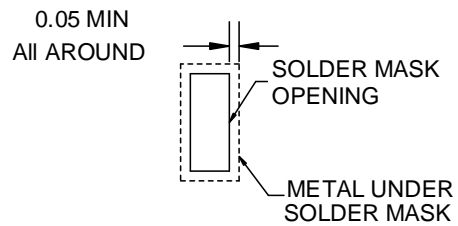

SOLDER MASK DEFINED

Unit: mm

REVISION HISTORY

Version	Date	Change Record
V1.0	January 2021	First version.
V1.1	July 2022	<ol style="list-style-type: none">1. I_{LIM_ST} update description2. Update accuracy of I_{LIMIT}3. Update IQ4. Update page14

awinic Confidential

DISCLAIMER

Information in this document is believed to be accurate and reliable. However, Shanghai AWINIC Technology Co., Ltd (AWINIC Technology) does not give any representations or warranties, expressed or implied, as to the accuracy or completeness of such information and shall have no liability for the consequences of use of such information.

AWINIC Technology reserves the right to make changes to information published in this document, including without limitation specifications and product descriptions, at any time and without notice. Customers shall obtain the latest relevant information before placing orders and shall verify that such information is current and complete. This document supersedes and replaces all information supplied prior to the publication hereof.

AWINIC Technology products are not designed, authorized or warranted to be suitable for use in medical, military, aircraft, space or life support equipment, nor in applications where failure or malfunction of an AWINIC Technology product can reasonably be expected to result in personal injury, death or severe property or environmental damage. AWINIC Technology accepts no liability for inclusion and/or use of AWINIC Technology products in such equipment or applications and therefore such inclusion and/or use is at the customer's own risk.

Applications that are described herein for any of these products are for illustrative purposes only. AWINIC Technology makes no representation or warranty that such applications will be suitable for the specified use without further testing or modification.

All products are sold subject to the general terms and conditions of commercial sale supplied at the time of order acknowledgement.

Nothing in this document may be interpreted or construed as an offer to sell products that is open for acceptance or the grant, conveyance or implication of any license under any copyrights, patents or other industrial or intellectual property rights.

Reproduction of AWINIC information in AWINIC data books or data sheets is permissible only if reproduction is without alteration and is accompanied by all associated warranties, conditions, limitations, and notices. AWINIC is not responsible or liable for such altered documentation. Information of third parties may be subject to additional restrictions.

Resale of AWINIC components or services with statements different from or beyond the parameters stated by AWINIC for that component or service voids all express and any implied warranties for the associated AWINIC component or service and is an unfair and deceptive business practice. AWINIC is not responsible or liable for any such statements.