

Single Cell Li-ion Battery Charger

Features

- High-Accuracy Voltage and Current Regulation
- Charge Voltage Regulation Accuracy: $\pm 0.5\%$ (0°C to 50°C)
- Charge Current Accuracy: $\pm 10\%$
- Maximum 28V Input Voltage Rating with Over-Voltage Protection
- Complete Charge Process with Pre-Charge, Constant Current Charging(CC) and Constant Voltage Charging(CV)
- Programmable CC Charge current
- Programmable Charge Termination and Autonomous Recharge
- Wide Range Fast Charge Current: 5mA~800mA
- Strong Robust Protection: VBUS OVP, Battery OVP, Reverse Leakage Protection, Thermal Protection
- Less than 1 μ A Leakage current from the Battery when Input Power absented or Charger Disabled
- Fully Integrated Dynamic Input Power Management
- DFN 2mm X2mm X0.75mm-8L package
- IEC62368-1 Approved-File No.BE-37454

Applications

- Smart Handheld Devices
- Wearable Devices
- Smart Watches
- Fitness Accessories
- Wireless Remote

General Description

The AW32005ZXXX is a highly-integrated Li-Ion/Li-Polymer battery linear charger. The AW32005ZXXX is targeted at space limited portable applications. The chip can take input power from either an AC adaptor or a USB port to charge the battery. The charger accepts an input voltage up to 28V but is disabled when the input voltage exceeds the OVP threshold, typically 6.8V (AW32005L) /13.5V (AW32005H), to prevent excessive power dissipation.

The charge process of AW32005ZXXX includes: Pre-Charge, Constant Current Charging and Constant Voltage Regulation. The charge current and the termination charge current are programmable with external resistors. The charge process runs automatically and recharging occurs when the battery voltage drops below VBAT_REG-VRCH after charge done status. In all charge phases, an internal control loop monitors the IC junction temperature and reduces the charge current if an internal temperature threshold is exceeded. Additionally, input over voltage protection, input under voltage lockout protection and input headroom voltage detection are integrated for good input source monitor.

AW32005ZXXX support status indication function using the CHG and PPR pin which allow simple interface to a microprocessor or LEDs. The chip consume less than 1 μ A leakage from battery when Input Power absented or Charger Disabled. It is available DFN-2x2-8L package.

Typical Application Circuit

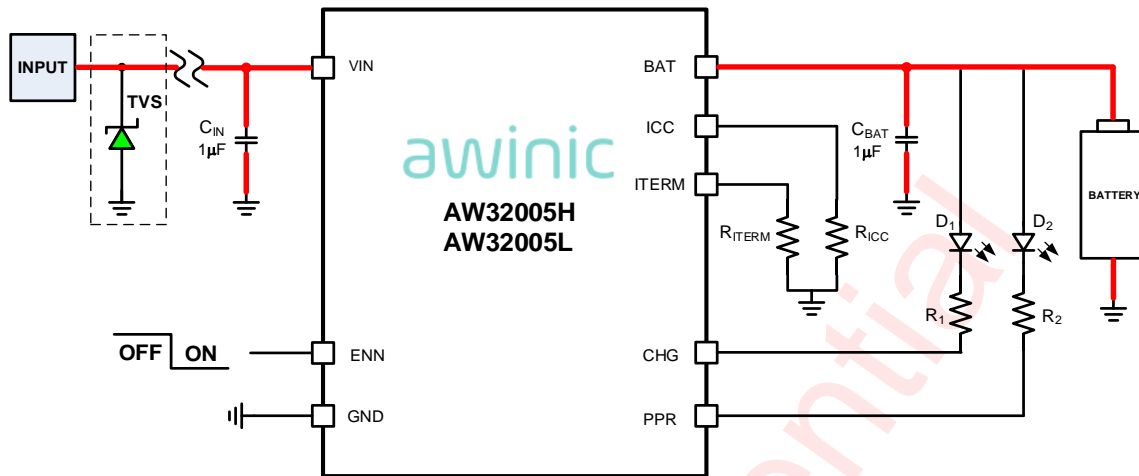

Figure 1 Typical Application Circuit of AW32005H/AW32005L

Name Rule

AW32005 Z XXX DNR

Output Voltage

E.g.
420: Output Voltage 4.2V

Ovp Voltage

L: 6.8V
H: 13.5V

Device Comparison Table

PART No.	OVP VOLTAGE	VBAT VOLTAGE
AW32005L420DNR	6.80 V	4.20 V
AW32005L435DNR	6.80 V	4.35 V
AW32005L440DNR	6.80 V	4.40 V
AW32005L444DNR	6.80 V	4.44 V
AW32005H420DNR	13.5 V	4.20 V
AW32005H435DNR	13.5 V	4.35 V
AW32005H440DNR	13.5 V	4.40 V
AW32005H444DNR	13.5 V	4.44 V

Awinic Confidential

Pin Configuration and Top Mark

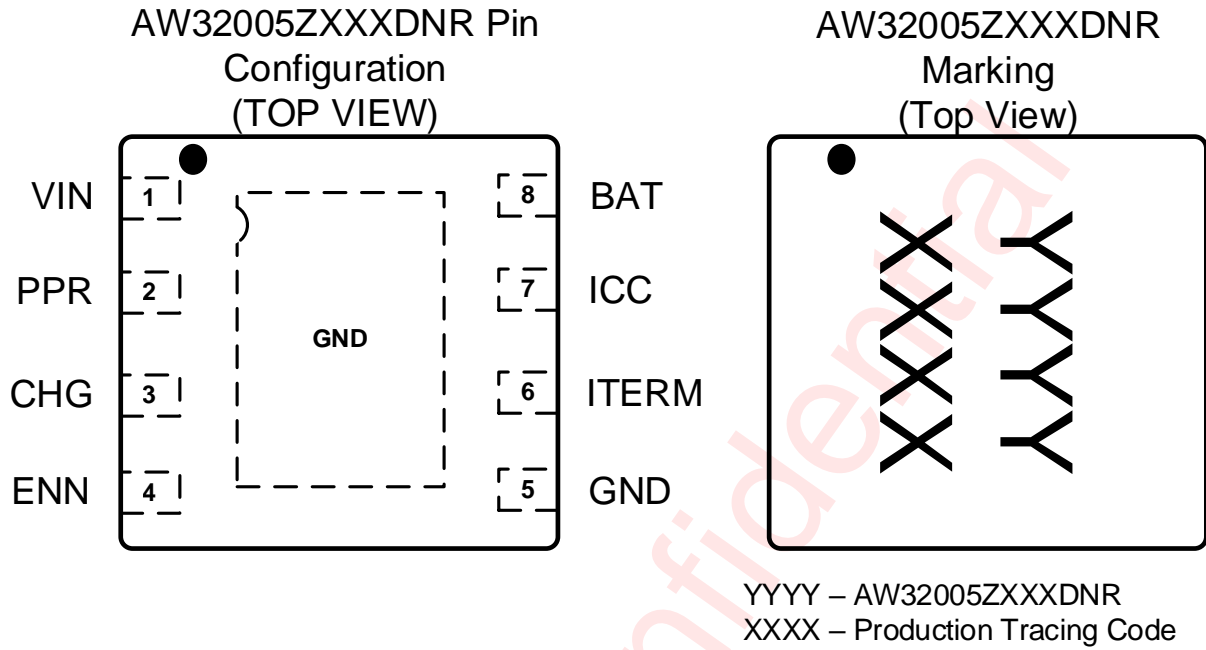

Figure 2 Pin Configuration and Top Mark

Pin Definition

No.	NAME	DESCRIPTION
1	VIN	Power Input. The absolute maximum input voltage is 28V. A 1μF or larger value X5R ceramic capacitor is recommended to be placed very close to the input pin for decoupling purpose. Additional capacitance may be required to provide a stable input voltage.
2	PPR	Open-Drain Power Presence Indication. The open-drain MOSFET turns on when the input voltage is above the POR threshold and off otherwise. This pin is capable to sink 15mA current to drive an LED. This pin is independent on the pin input.
3	CHG	Open-Drain Charge Indication. This pin outputs a logic low when a charge cycle starts and turns to high impedance when the full-of-charge (FOC) condition is qualified. This pin is capable to sink 15mA current to drive an LED. When the charger is disabled, the CHG pin outputs high impedance.
4	ENN	Enable Input. This is a logic input pin to disable or enable the charger. Drive high to disable the charger. When this pin is driven to low or left floating, the charger is enabled. This pin has an internal 1.7MΩ pull-down resistor.
5	GND	System Ground.
6	ITERM	Full-of-Charge (FOC) Current Programming Pin. Connect a resistor between this pin and the GND pin to set the FOC current. The FOC current I_{TERM} can be programmed by the following equation: $I_{TERM} = \frac{10530}{R_{ITERM}} + 2.9 \text{ (mA)}$ where R_{ITERM} is in kΩ.
7	ICC	Charge-Current Programming and Monitoring Pin. Connect a resistor between this pin and the GND pin to set the charge current limit determined by the following equation: $I_{CC} = \frac{12000}{R_{ICC}} \text{ (mA)}$ where R_{ICC} is in kΩ. The resistor should be located very close to this pin. The ICC pin voltage also monitors the actual charge current during the entire charge cycle, including the trickle, constant-current, and constant-voltage phases. When disabled, $V_{ICC} = 0V$.
8	BAT	Charger Output Pin. Connect this pin to the battery. A 1μF or larger X5R ceramic capacitor is recommended for decoupling and stability purposes. When the ENN pin is pulled to logic high, the BAT output is disabled.

Ordering Information

Part Number	Temperature	Package	Marking	Moisture Sensitivity Level	Environmental Information	Delivery Form
AW32005L420DNR	-40°C~85°C	DFN2mm x 2mm x 0.75mm-8L	36T7	MSL1	ROHS+HF	3000 units/ Tape and Reel
AW32005L435DNR	-40°C~85°C	DFN2mm x 2mm x 0.75mm-8L	36UD	MSL1	ROHS+HF	3000 units/ Tape and Reel
AW32005L440DNR	-40°C~85°C	DFN2mm x 2mm x 0.75mm-8L	UFCG	MSL1	ROHS+HF	3000 units/ Tape and Reel
AW32005L444DNR	-40°C~85°C	DFN2mm x 2mm x 0.75mm-8L	2ABM	MSL1	ROHS+HF	3000 units/ Tape and Reel
AW32005H420DNR	-40°C~85°C	DFN2mm x 2mm x 0.75mm-8L	WEFE	MSL1	ROHS+HF	3000 units/ Tape and Reel
AW32005H435DNR	-40°C~85°C	DFN2mm x 2mm x 0.75mm-8L	6NVF	MSL1	ROHS+HF	3000 units/ Tape and Reel
AW32005H440DNR	-40°C~85°C	DFN2mm x 2mm x 0.75mm-8L	PT7F	MSL1	ROHS+HF	3000 units/ Tape and Reel
AW32005H444DNR	-40°C~85°C	DFN2mm x 2mm x 0.75mm-8L	STL5	MSL1	ROHS+HF	3000 units/ Tape and Reel

Absolute Maximum Ratings^(NOTE1)

PARAMETERS		MIN	MAX	UNIT
Input voltage range V_{IN} (with respect to GND)	V_{IN}	-0.5	28	V
Other pins voltage range (with respect to GND)	ENN, BAT, PPR, CHG, ICC, ITERM	-0.3	6	V
Operating free-air temperature range		-40	85	°C
Operating junction temperature T_J		-40	150	°C
Storage temperature T_{STG}		-65	150	°C
Lead temperature (Soldering 10 seconds)			260	°C

NOTE1: Conditions out of those ranges listed in "absolute maximum ratings" may cause permanent damages to the device. In spite of the limits above, functional operation conditions of the device should within the ranges listed in "recommended operating conditions". Exposure to absolute-maximum-rated conditions for prolonged periods may affect device reliability.

ESD Rating and Latch Up

PARAMETERS	VALUE	UNIT
HBM (Human Body Model) ^(NOTE 2)	±6	kV
CDM ^(NOTE 3)	±1.5	kV
Latch-Up ^(NOTE 4)	+IT: 200 -IT: -200	mA

NOTE2: The human body model is a 100pF capacitor discharged through a 1.5kΩ resistor into each pin. Test method: ESDA/JEDEC JS-001-2017

NOTE3: Test method: ESDA/JEDEC JS-002-2018

NOTE4: Test method: JESD78E

Recommended Operating Conditions

PARAMETERS	MIN	TYP	MAX	UNIT
Supply voltage range V_{IN} (AW32005LXXX)	4		6.8	V
Supply voltage range V_{IN} (AW32005HXXX)	4		13.5	V
Charge current I_{CHG}	5		800	mA
Termination charge current I_{TERM}	2.9		60	mA
Battery regulated voltage V_{BAT_REG}	3.52		4.52	V
Operating junction temperature T_J	-40		125	°C

Thermal Information

PARAMETERS	VALUE	UNIT
Junction-to-ambient thermal resistance θ_{JA}	122.6	°C/W

Electrical Characteristics

$V_{IN}=5V$, $V_{BAT}=4.35V$, $T_J=25^{\circ}C$ for typical values (unless otherwise noted)

PARAMETER		TEST CONDITION	MIN	TYP	MAX	UNIT	
INPUT SOURCE AND BATTERY PROTECTION							
V_{IN_UVLO}	UVLO threshold voltage, entry UVLO		V_{IN} falling	3.5	3.6	3.7	V
	Hysteresis for UVLO		V_{IN} rising		300		mV
	Deglitch time for V_{IN_UVLO}		Exits UVLO		30		ms
V_{IN_OVP}	V_{IN_OVP} threshold voltage	AW32005LXXX	V_{IN} rising	6.6	6.8	7	V
		AW32005HXXX		13.1	13.5	13.9	V
	V_{IN_OVP} hysteresis		V_{IN} falling from above V_{IN_OVP}		350		mV
V_{IN_Clamp}	V_{IN} Clamp voltage		V_{IN} rising	5.25	5.5	5.7	V
			V_{IN} falling	5.05	5.3	5.5	V
V_{HDRM}	Input vs. battery voltage headroom threshold		V_{IN} rising	80	130	170	mV
	Input vs. battery voltage headroom threshold hysteresis		V_{IN} falling		60		mV
CHARGE PROCESS							
V_{OREG}	Output regulation voltage	AW32005Z420DNR	$V_{IN}=5V$, $R_{ICC}=300K$	4.18	4.20	4.22	V
		AW32005Z435DNR		4.33	4.35	4.37	V
		AW32005Z444DNR		4.42	4.44	4.46	V
	Output regulation voltage accuracy		$T_J=0^{\circ}C\sim 50^{\circ}C$	-0.5		0.5	%
V_{RCH}	Recharge threshold		V_{BAT} falling	140	200	260	mV
	V_{RCH} hysteresis				50		mV
V_{BAT_OVP}	Battery OVP threshold voltage		V_{BAT} threshold over V_{OREG} to turn off charger during charge	80	130	180	mV
	V_{BAT_OVP} hysteresis				50		mV
V_{BAT_PRE}	Pre charge to fast charge threshold		$V_{OREG} < 3.56$	2.4	2.5	2.6	V
			$3.60 < V_{OREG} < 3.88$	2.45	2.55	2.65	V
			$3.92 < V_{OREG} < 4.2$	2.5	2.6	2.7	V
			$4.24 < V_{OREG} < 4.52$	2.55	2.65	2.75	V
	V_{BAT_PRE} hysteresis		V_{BAT} falling		200		mV
DYNAMIC POWER MANAGEMENT							
V_{IN_DPM}	Dynamic power management clamps V_{IN}			V_{OREG}	$V_{OREG} + 0.2$	$V_{OREG} + 0.4$	V

PARAMETER		TEST CONDITION	MIN	TYP	MAX	UNIT	
POWER MOSFET ON-RESISTANCE							
R _{dson}	IN to BAT Power MOS on resistance	Power MOS fully turn on	350	420	450	mΩ	
STANDBY CURRENT							
I _{IN_Q}	Input quiescent current	V _{IN} =5V, ENN=0, charge enable, I _{CHG} =8mA;	800	1030	1800	μA	
		V _{IN} =5V, ENN=1, charge disabled, I _{CHG} =0;	0.8	1	1.6	μA	
		V _{IN} =5V, ENN=0, charge done;	30	55	100	μA	
I _{BAT_INOFF}	Battery current when V _{IN} =0	V _{IN} =0V, V _{BAT} =4.2V	-1	0	1	μA	
I _{BAT_CHGDN}	Battery charge done current	V _{IN} =5V, ENN=0, charge done, I _{CHG} =0;	0	0.1	1	μA	
CHARGE CURRENT							
I _{CHG}	Output charge regulation current programmable range		V _{BAT_PRE} <V _{BAT} <V _{OREG}	5		800	mA
	Accuracy for charge current regulation	AW32005ZXXXDNR (except for AW32005L420DNR & AW32005L440DNR)	I _{CHG} =40mA	38	40	42	mA
			I _{CHG} =200mA	186	200	216	mA
			I _{CHG} =400mA	390	400	410	mA
			I _{CHG} >40mA	-10		10	%
	Accuracy for charge current regulation	AW32005L420DNR & AW32005L440DNR	I _{CHG} =20mA	17.5	20	22.5	mA
			I _{CHG} =62mA	54.25	62	69.75	mA
			I _{CHG} =74mA	64.75	74	83.25	mA
			I _{CHG} =86mA	75.25	86	96.75	mA
			I _{CHG} >98mA & 30mA<I _{CHG} <50mA	-10		10	%
I _{PRE}	Pre-charge current	V _{BAT} < V _{BAT_PRE}		20		%I _{CHG}	
I _{TERM}	Termination charge current threshold, programmable	R _{TERM} Float or Short	1.4	2.9	4.4	mA	
		R _{TERM} =5M ohm	3	5	7	mA	
		R _{TERM} =500K ohm	23	25	27	mA	
T _{TERM}	Termination deglitch time	I _{CHG} <I _{TERM} ,		3.2		s	
LOGIC INPUT AND OUTPUTS							
V _{ENN_H}	ENN PIN Logic Input High		0.77	0.83	0.89	V	
V _{ENN_L}	ENN PIN Logic Input Low		0.68	0.72	0.76	V	
R _{ENN}	ENN Pin Internal Pull - Down Resistance	V _{ENN} =5.5V	1.1	1.7	2.4	MΩ	
R _{CHG}	CHG Pin On-Resistance when LOW	I _{CHG} =5mA	28	35.5	42	Ω	

PARAMETER		TEST CONDITION	MIN	TYP	MAX	UNIT
I _{LEAK_CHG}	CHG Pin Leakage Current when High Impedence	V _{CHG} =5.5V			0.1	μA
R _{PPR}	PPR Pin On-Resistance when LOW	I _{PPR} =5mA	28	35.5	42	Ω
I _{LEAK_PPR}	PPR Pin Leakage Current when High Impedence	V _{PPR} =5.5V			0.1	μA
THERMAL PROTECTION						
T _{J_REG}	Junction temperature regulation	Junction temperature rising		120		°C
T _{OTP}	Overheating shutdown protection temperature	Junction temperature rising		150		°C
	Thermal hysteresis for T _{OTP}	Junction temperature falling		20		°C

Typical Characteristics

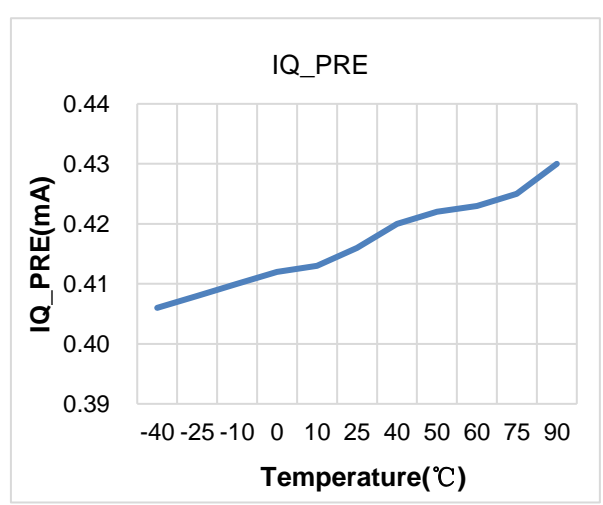
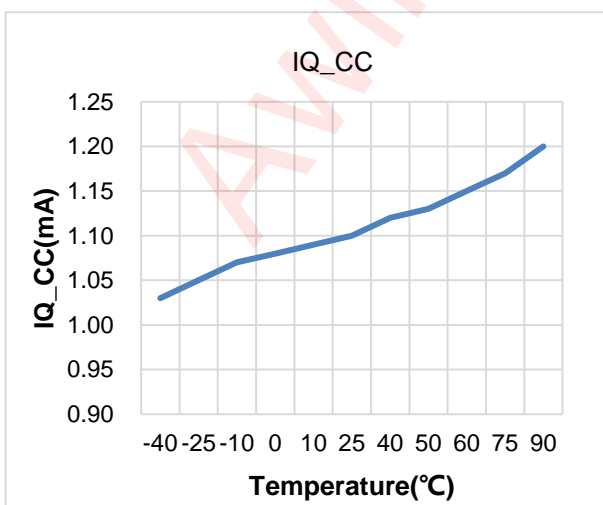
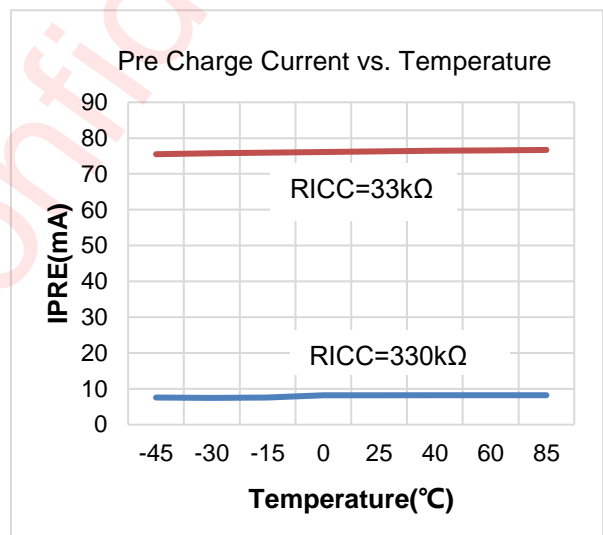
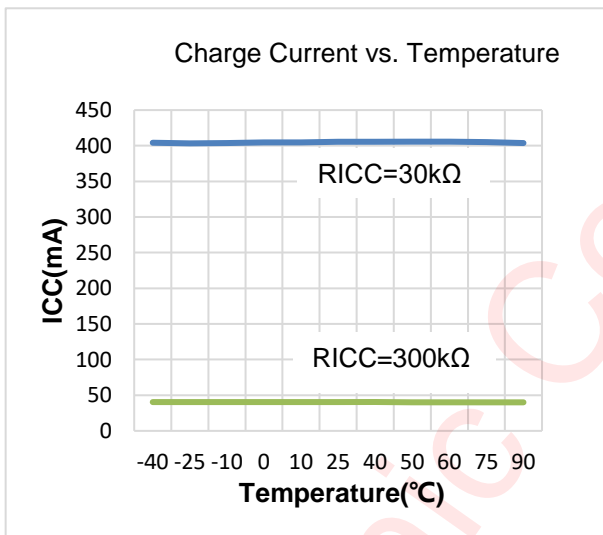
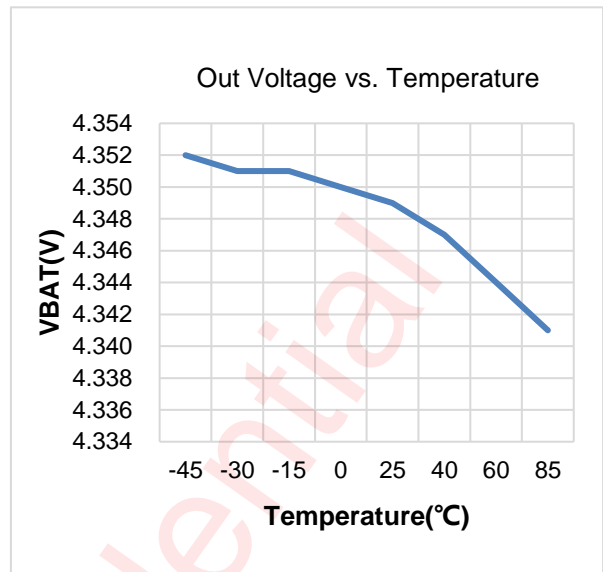
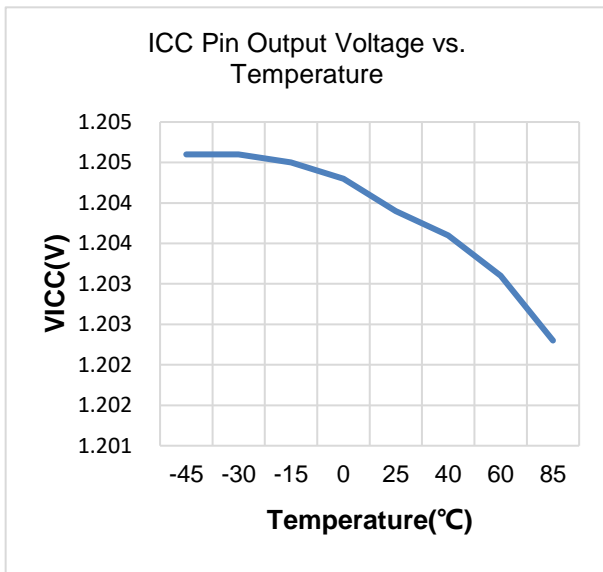

Typical Characteristics (Continued)

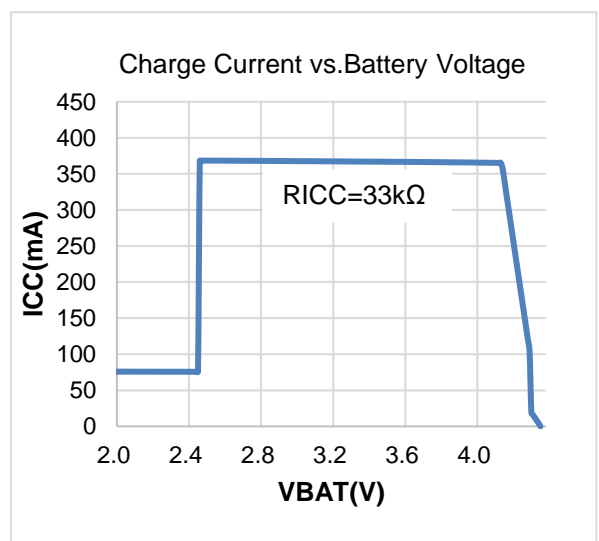
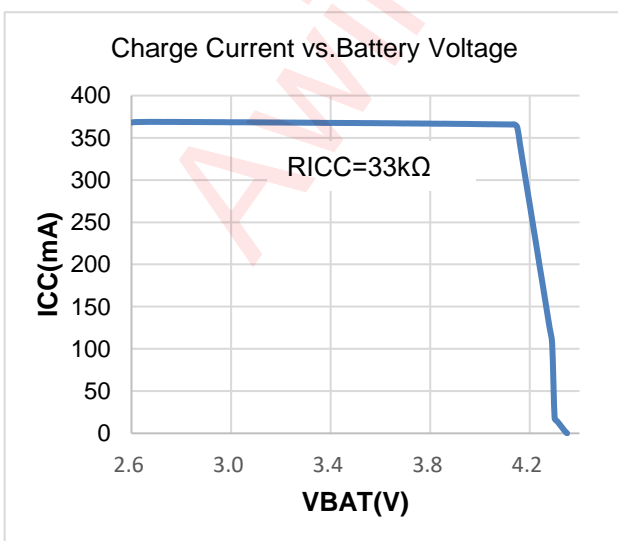
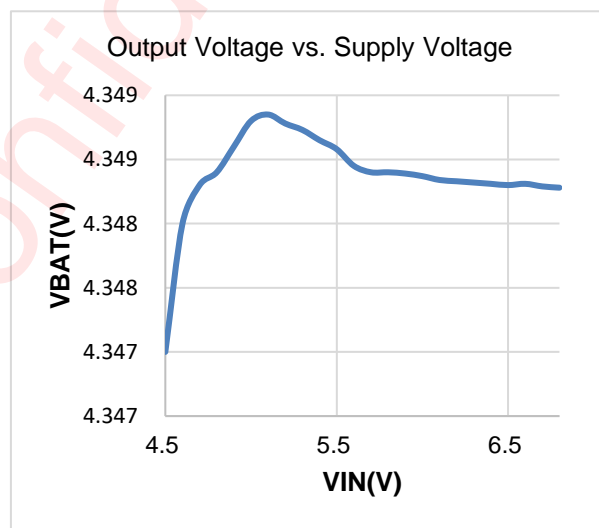
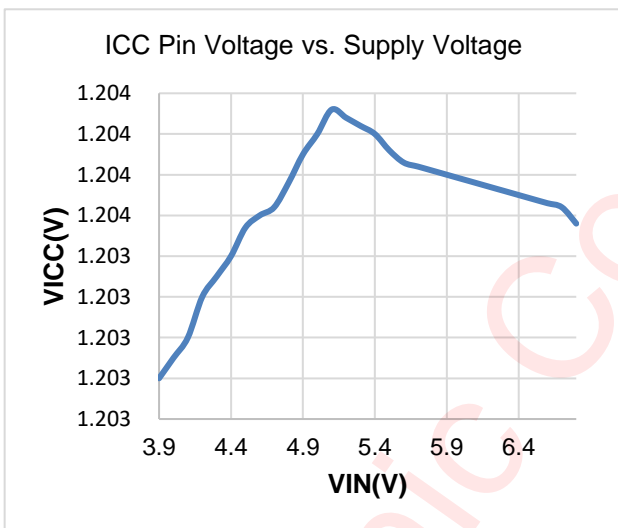
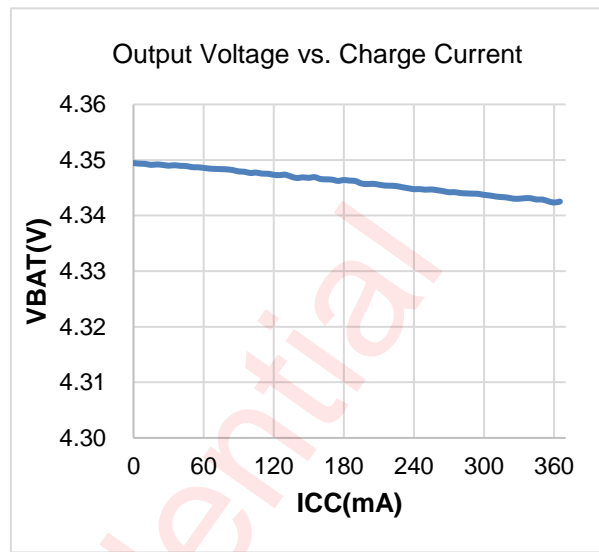
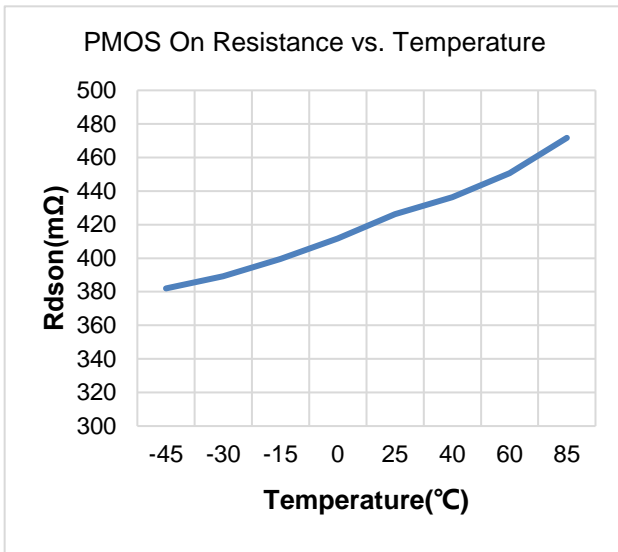

Typical Characteristics (Continued)

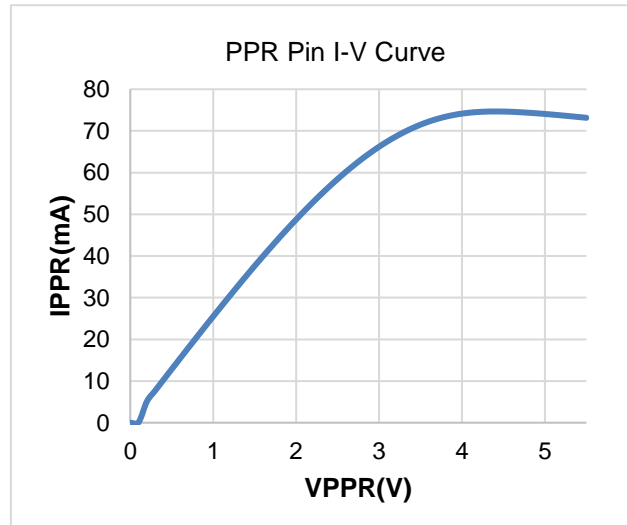
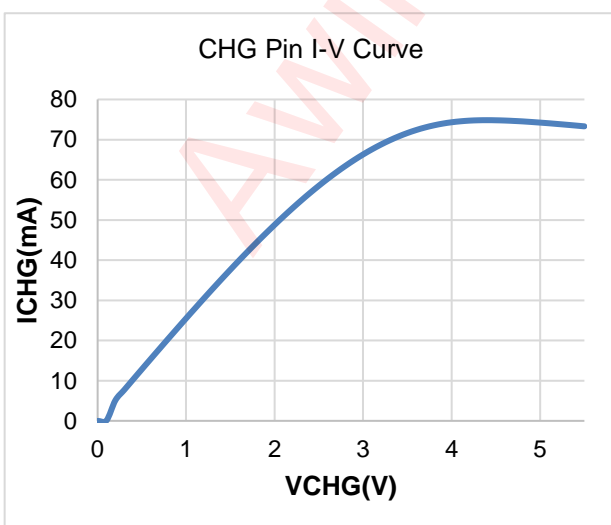
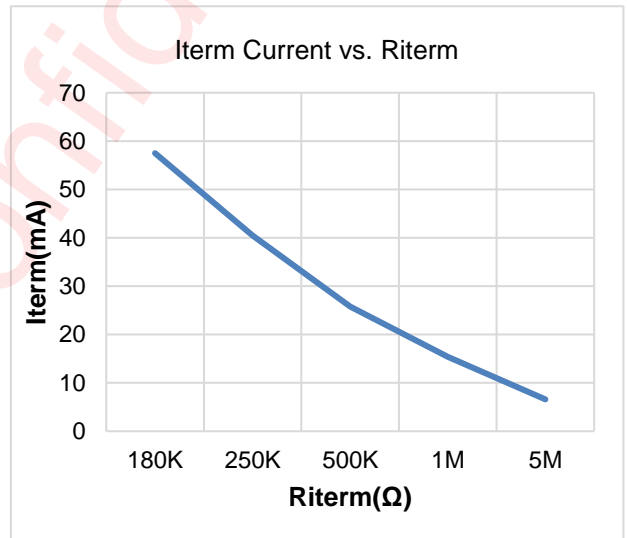
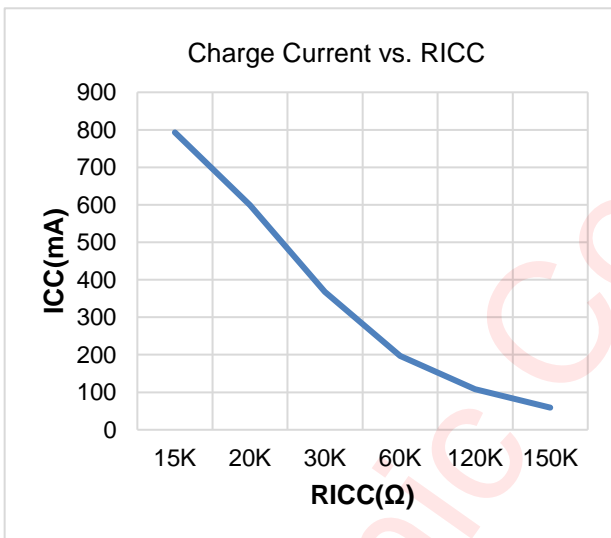
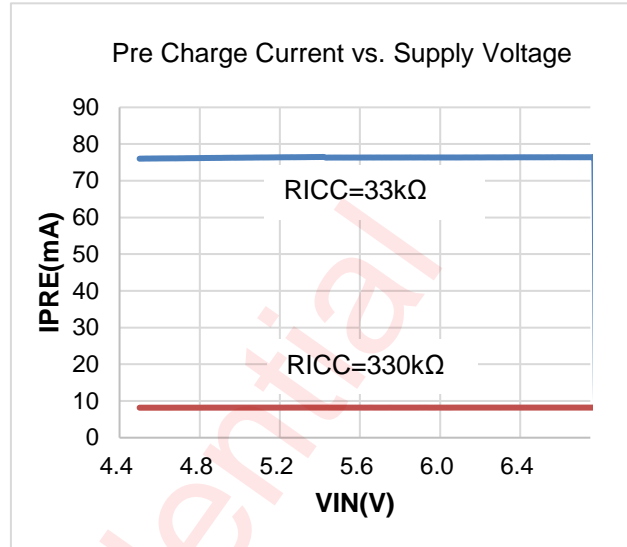
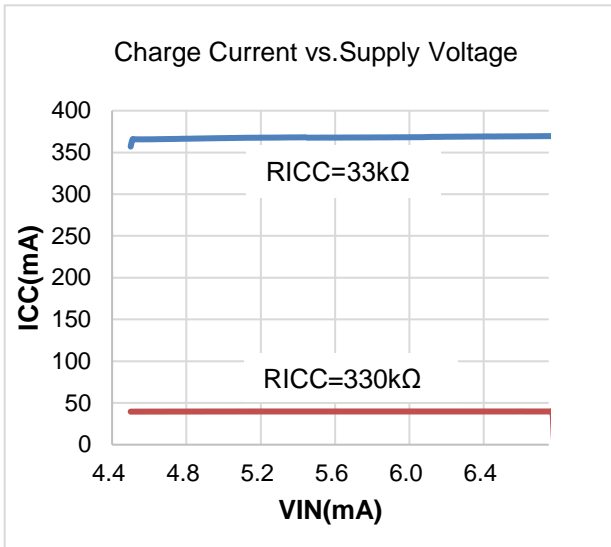

Typical Characteristics (Continued)

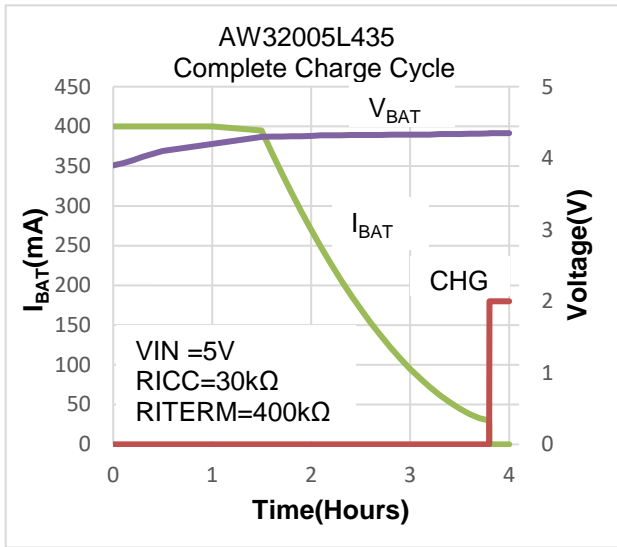

Awinic Confidential

Functional Diagram

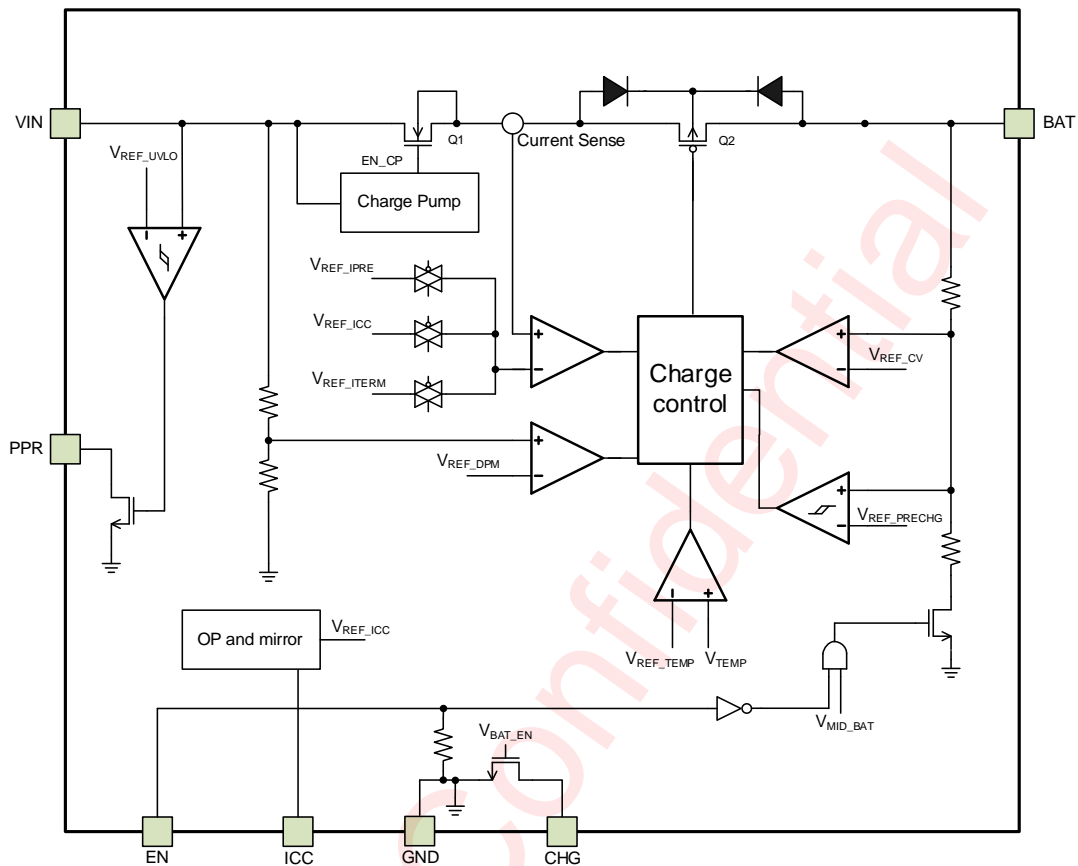

Figure 3 Functional Block Diagram

Detailed Functional Description

The AW32005ZXXX is a highly integrated linear battery charger. The full-charge process of AW32005ZXXX not only includes pre-charge, constant-current fast charge (CC) and constant voltage (CV) regulation, but also includes charge termination, auto-recharge, etc. When the input power is limited by input current or voltage, the charge current will decrease automatically.

The charge current and the termination charge current are programmable with external resistors. The charge process runs automatically and recharging occurs when the battery voltage drops below $V_{BAT_REG} - V_{RCH}$ after charge done status. In all charge phases, an internal control loop monitors the IC junction temperature and reduces the charge current if an internal temperature threshold is exceeded. Additionally, input over voltage protection, input under voltage lockout protection and input headroom voltage detection are integrated for good input source monitor.

Operation

When AW32005ZXXX operates in Charge Mode, the input Voltage DPM, thermal regulation and other functions are available.

Enable

AW32005ZXXX is enabled by pulling ENN pin low, and system shuts down when the ENN pin pull high. When ENN pin is floating, the chip is enable. ENN pin has a 1.7MΩ internal pull-down resistance.

Input Voltage Power Regulation

The input voltage DPM(dynamic power management) function is built in AW32005ZXXX. When the load is over the input power capacity, the input voltage also can be regulated to V_{IN_DPM} for the input voltage-based DPM regulation. Once the current load above the input power capacity, input voltage decreases below the DPM threshold V_{IN_DPM} , which triggers the DPM control loop. Then VIN-BAT path current is regulated and decreases, until the input voltage stops falling and holds on almost DPM threshold voltage. If the load decreases below the input power capacity, the input voltage will rise over the DPM threshold and the device will exit DPM control loop.

Battery Charge flow

The AW32005ZXXX has three main charging processes: pre-charge, fast-current charge, and constant-voltage charge:

- Pre-charge: In the pre-charge process, the IC charges the deeply depleted battery safely with small current until the battery voltage rises to the pre-charge threshold(V_{BAT_PRE}), in which the chip enters the fast-charge process. The pre-charge current is 20% of Fast charge current programmed by ICC pin. If the V_{BAT} is not exceeding V_{BAT_PRE} before the pre-charge timer expires (1 hour), the charge cycle stops, and a corresponding timeout fault signal is asserted. Only power on from VIN or ENN can trigger recharge form charge timer expires fault.
- Fast charge: When V_{BAT} exceeds V_{BAT_PRE} , the AW32005ZXXX enters the fast charge process. The fast-charge current is programmed by external resistance.
- Constant-voltage charge: The charge mode changes from CC mode to CV mode when the V_{BAT} rises to the battery-full voltage (V_{BAT_REG}) . At the same time, the charge current starts decreasing in CV charge process. When the charge current is smaller than termination current threshold I_{TERM} for 3.2s in CV process, the charge cycle will be completed, and the charge status is updated to charge done. If the V_{BAT} is not increasing to V_{BAT_REG} before the CC-charge timer expires (4 hours), the charge cycle stops, and a corresponding timeout fault signal is asserted. Only power on from VIN or ENN can trigger recharge form charge timer expires fault.

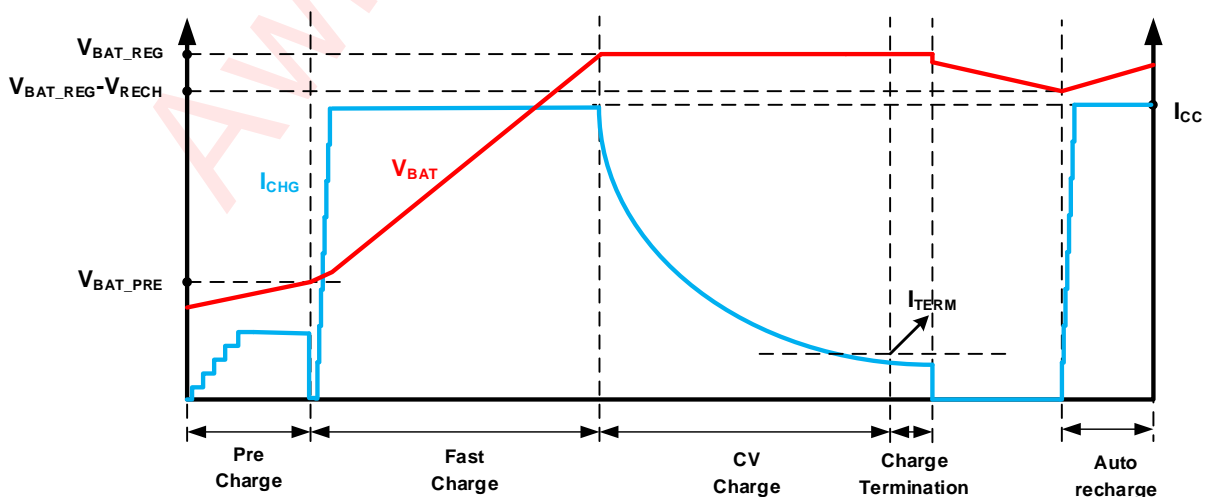

Figure 4 Battery Charge Profile

Automatic Recharge

After the charge process is completed and charging cycle is terminated, the system's consumption or battery self-discharge may cause the battery voltage decreasing. When the battery voltage falls below the recharge threshold and V_{IN} is still in the operating range, another new charging cycle will be start automatically.

Thermal Regulation

The AW32005ZXXX build-in thermal regulation function to avoid overheating the chip and maximize power delivery. When the internal junction temperature rising and reaches the preset limit T_{J_REG} ($120^{\circ}C$), the charge current starts reducing to prevent dangerous high power dissipation. The charge current decreases continually when the temperature falling.

Protection Operation

The AW32005ZXXX has input OVP, UVLO, battery OVP and other functions to protect its normal operation.

Input OVP and UVLO

The AW32005ZXXX has an input UVLO and over-voltage protection (OVP) threshold. The Q1 is turned off immediately when the input voltage is out of its operating range.

The input over-voltage protection is integrated to prevent the device and other components from damage caused by the high input voltage (Voltage from V_{IN} to GND). If the voltage at V_{IN} pin exceeds V_{IN_OVP} threshold(6.8V typical), the chip will turn off Q1 and send out a fault pulse. When V_{IN} drops lower than the input overvoltage exit threshold (6.5V typical), Q1 will be turned on again.

When V_{IN} falls below V_{UVLO} , the Q1 is also turned off and the input to system loop controller is shut down. Once V_{IN} rises above $V_{UVLO}+300mV$, the Q1 is turned on and relative circuits start working.

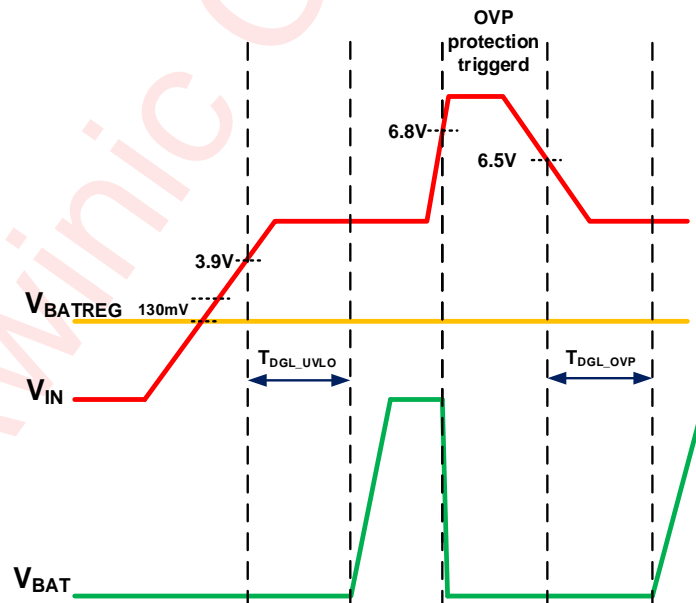

Figure 5 Input Power Detection Operation

Battery OVP

The AW32005ZXXX has battery over-voltage protection (BOVP) function (about 130mV higher than V_{BAT_REG}). When the battery OVP event occurs, AW32005ZXXX will stop the current charging cycle immediately and asserts a fault.

PPR Indication

The PPR pin is an open-drain output to indicate the presence of input power. The PPR open-drain circuit is on when the input voltage is above the POR threshold and off otherwise. This pin is capable to sink 15mA current to drive an LED. The maximum voltage rating for this pin is 6V.

CHG Indication

CHG pin is an Open-Drain Charge Indication. This pin outputs a logic low when a charge cycle starts and turns to high impedance when the full-of-charge (FOC) condition is qualified. This pin is capable to sink 15mA current to drive an LED. When the charger is disabled, the CHG pin outputs high impedance.

Over temperature Protection(OTP)

The internal junction temperature is monitored continuously to avoid destroy by abnormal high temperature . When the internal junction temperature reaches 150°C, the Q1 and Q2 will turn off and charge procedure is stopped. The chip will recover from OTP status when the temperature falls below the low threshold 130°C.

Short Circuit Protection(SCP)

The AW32005ZXXX supports SCP function for ICC pin, ITERM pin, BAT pin. When ICC pin is shorted to GND, system stops charging until the abnormality is removed. When ITERM pin is connected to GND, system adjusts the termination current to fixed 2.9mA regardless of how much the termination threshold is. The termination current threshold is recover if the abnormality is removed. When BAT pin to GND short circuit happening, charge current is about 17mA.

Safety timer

In consideration of the abnormal battery conditions, a pre-charge and fast-charge safety timer is designed in the AW32005ZXXX to prevent an extra-long time charging cycle. The pre-charge safety timer is 1hour, and the fast-charge safety timer is 5 hours. Once the battery enters fast-charge mode, The fast charge safety timer starts.

Application Information

External Capacitor

The external capacitor cannot be absent for the operation of AW32005ZXXX. Carefully selecting suitable capacitor is important to guarantee the AW32005ZXXX working perfectly on the space limited board.

A 1 μ F ceramic capacitor with high level voltage endurance (at least 30V) between IN and GND is recommended. This capacitor rejects input power supply ripple and enhance the stability of DPM loop.

A least 1 μ F ceramic capacitor is also needed between BAT and GND for some application.

PCB Layout Consideration

To obtain the optimal performance, PCB layout should be considered carefully. Guidelines below should be obeyed,

1. All peripherals components should be placed as close to the chip as possible. C_{IN} and C_{BAT} should be close to VIN and BAT pins respectively.
2. IN and BAT pins are input and output of the chip with large current. Make sure the routes of VIN, BAT and GND are sufficient wide and short to flow large charging current.
3. The exposed pad of the chip and GND pin must be well connected to the GND of the PCB and add as many thermal vias as possible on the PCB for the integrity of the GND and heat conductivity.

Tape and Reel Information

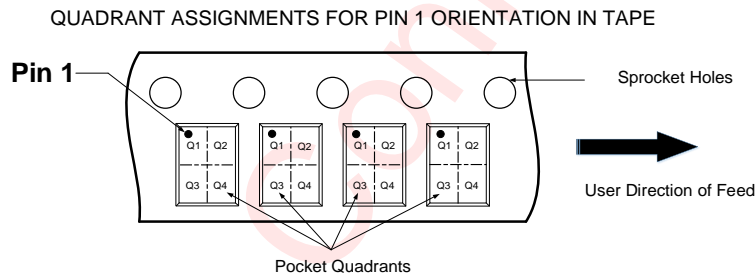
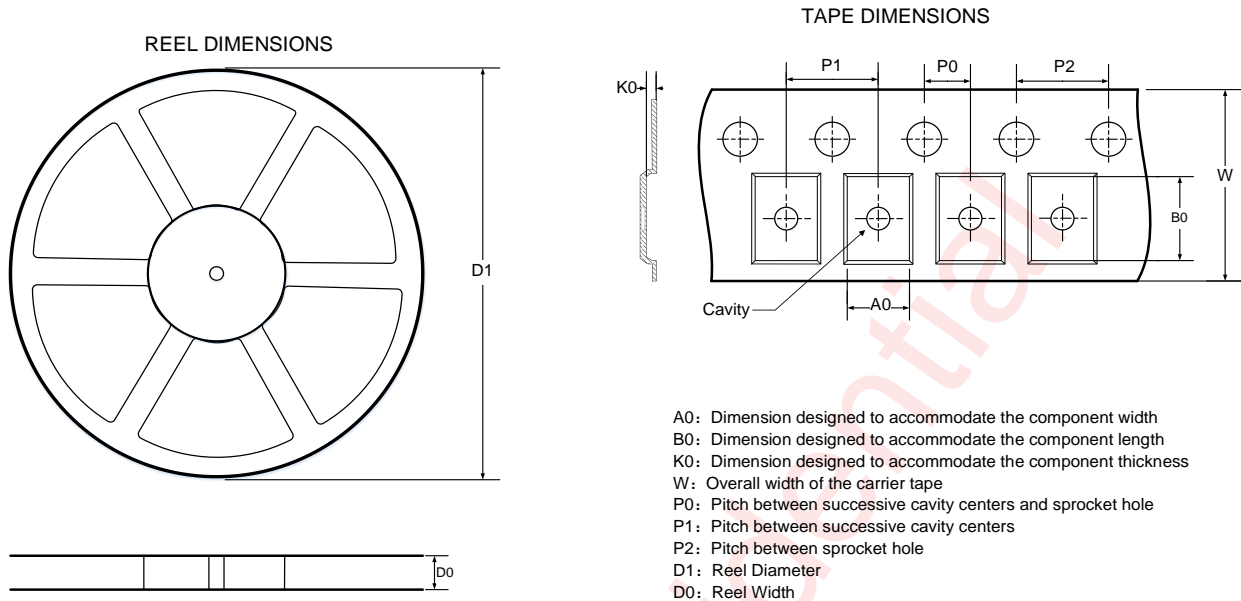

Note: The above picture is for reference only. Please refer to the value in the table below for the actual size

DIMENSIONS AND PIN1 ORIENTATION

D1 (mm)	D0 (mm)	A0 (mm)	B0 (mm)	K0 (mm)	P0 (mm)	P1 (mm)	P2 (mm)	W (mm)	Pin1 Quadrant
178.00	8.40	2.25	2.25	0.95	2.00	4.00	4.00	8.00	Q1

All dimensions are nominal

Package Description(POD)

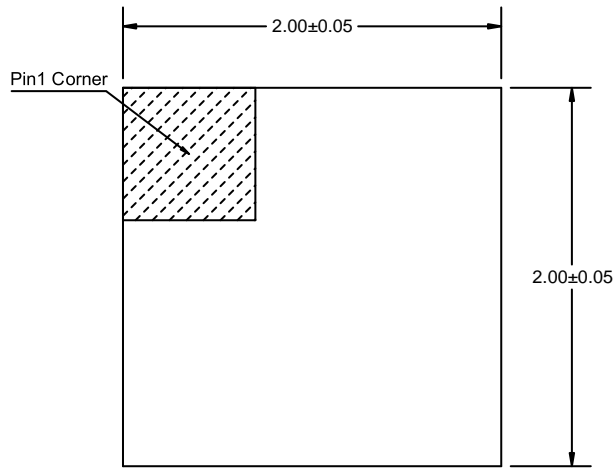

Top View

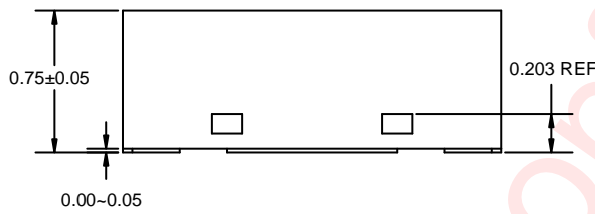

Side View

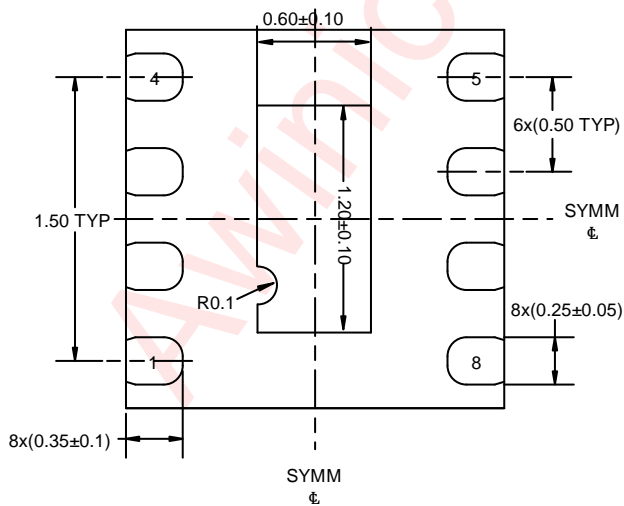

Bottom View

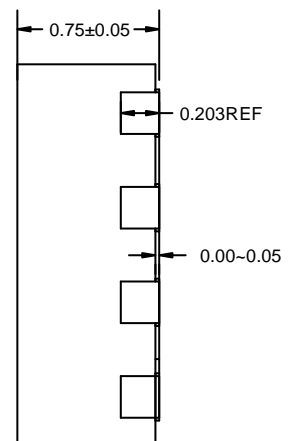

Side View

Unit: mm

Land Pattern Data

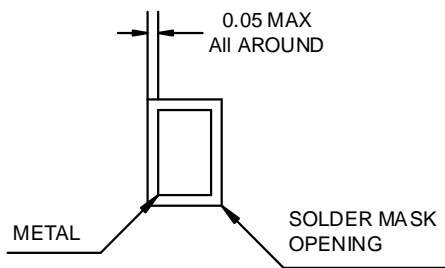
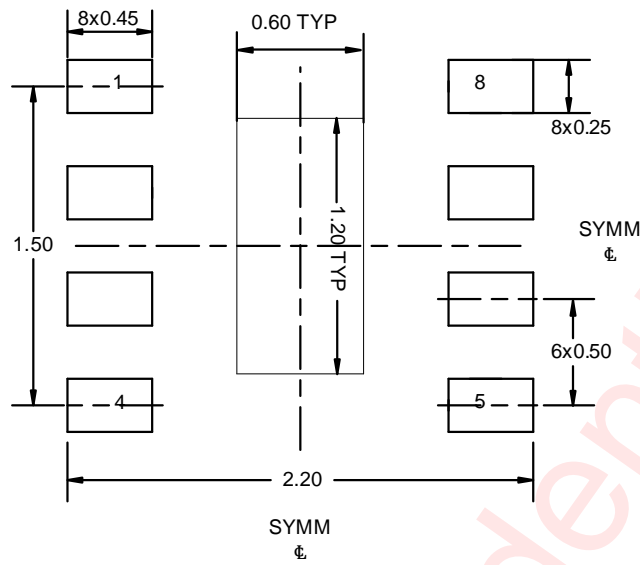

NON-SOLDER MASK DEFINED

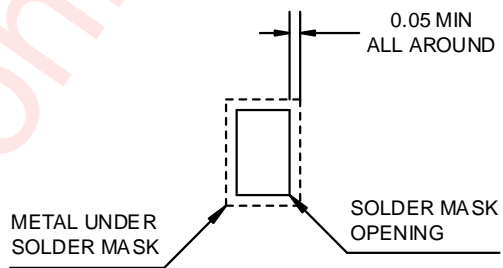

SOLDER MASK DEFINED

Unit: mm

Revision History

Version	Date	Change Record
V1.0	December 2021	Official Released
V1.1	December 2021	Add AW32005H/L440DNR
V1.2	March 2022	Add Features and Modify Termination Charge Current
V1.3	July 2022	Update the V_{BAT_PRE} Characteristic on Page9
V1.4	August 2022	Update the figure I_{term} Current vs. R_{item} on Page14
V1.5	January 2023	Update the Accuracy of I_{CHG} on Page10
V1.6	October 2024	Update the Accuracy of I_{CHG} on Page10

Awinic Confidential

Disclaimer

Information in this document is believed to be accurate and reliable. However, Shanghai AWINIC Technology Co., Ltd (AWINIC Technology) does not give any representations or warranties, expressed or implied, as to the accuracy or completeness of such information and shall have no liability for the consequences of use of such information.

AWINIC Technology reserves the right to make changes to information published in this document, including without limitation specifications and product descriptions, at any time and without notice. Customers shall obtain the latest relevant information before placing orders and shall verify that such information is current and complete. This document supersedes and replaces all information supplied prior to the publication hereof.

AWINIC Technology products are not designed, authorized or warranted to be suitable for use in medical, military, aircraft, space or life support equipment, nor in applications where failure or malfunction of an AWINIC Technology product can reasonably be expected to result in personal injury, death or severe property or environmental damage. AWINIC Technology accepts no liability for inclusion and/or use of AWINIC Technology products in such equipment or applications and therefore such inclusion and/or use is at the customer's own risk.

Applications that are described herein for any of these products are for illustrative purposes only. AWINIC Technology makes no representation or warranty that such applications will be suitable for the specified use without further testing or modification.

All products are sold subject to the general terms and conditions of commercial sale supplied at the time of order acknowledgement.

Nothing in this document may be interpreted or construed as an offer to sell products that is open for acceptance or the grant, conveyance or implication of any license under any copyrights, patents or other industrial or intellectual property rights.

Reproduction of AWINIC information in AWINIC data books or data sheets is permissible only if reproduction is without alteration and is accompanied by all associated warranties, conditions, limitations, and notices. AWINIC is not responsible or liable for such altered documentation. Information of third parties may be subject to additional restrictions.

Resale of AWINIC components or services with statements different from or beyond the parameters stated by AWINIC for that component or service voids all express and any implied warranties for the associated AWINIC component or service and is an unfair and deceptive business practice. AWINIC is not responsible or liable for any such statements.